

Goal orientations in sport: a causal model

Francisco P. Holgado¹, Leandro Navas² and Manuela López-Núñez³

¹National University of Distance Education, ²University of Alicante,

³C.P. Felipe León (Spain)

The study is based on research work relating goal orientation in sport with contextual variables and personal variables. The sample was 511 professional athletes. A “causal” model is proposed in which task and goal ego orientations are the dependent variables. A hypothetical model is obtained using structural equations modelling, supporting that: a) athletes who find satisfaction experimenting mastery, who perceive a motivational climate that rewards hard work and who believe that success depends on their effort, develop task goal orientation; and b) athletes who get satisfaction demonstrating greater capacity than the rest, who live a motivational climate that leads them to be better than the others and that only rewards the best players, and whose main motive for practising sport is to achieve certain social status and popularity, will have an ego goal orientation.

Key words: Goal orientations, beliefs about success in sport, motivational climate, task orientation, ego orientation.

Orientaciones de Meta en el deporte: un modelo causal. Este trabajo parte de las investigaciones que relacionan las orientaciones de meta en el deporte con variables contextuales, como el clima motivacional percibido, y con variables personales, tales como la satisfacción con los resultados deportivos, las creencias relacionadas con los factores implicados en la obtención del éxito y los motivos por lo que se practica deporte. La muestra está compuesta por 511 deportistas profesionales. Se llevan a cabo análisis de regresión múltiple y se propone un modelo causal en el que las variables a predecir son las orientaciones de meta, a la tarea y al ego. Con ecuaciones estructurales se contrasta un modelo hipotético, que presenta un ajuste adecuado, y que defiende que: a) el deportista que encuentra la satisfacción experimentando maestría, que percibe un clima motivacional que premia el trabajo duro y que cree que el éxito depende de su esfuerzo, desarrolla una orientación de meta a la tarea; y b) que el deportista que obtiene satisfacción demostrando mayor capacidad que los demás, que vive un clima motivacional que le conduce a superar a los otros y que recompensa sólo a los mejores jugadores, y que el principal motivo para practicar deporte es alcanzar un determinado estatus social y popularidad, tendrá una orientación de meta al ego.

Palabras clave: Orientaciones de meta, creencias de éxito en el deporte, clima motivacional, orientación a la tarea, orientación al ego.

Initially, goal orientation theory emerged in the educational field (Ames, 1984, 1992a; Dweck, 1986; Dweck & Elliot, 1983; Nicholls, 1984, 1989; Roberts, 1992), and later shifted to the sports' sphere where research work has demonstrated that there are two goal orientations: task orientation and ego orientation. In task orientation, the perception of competence is referred to oneself and to the subjective experience of improving one's performance and increasing one's skills. On the other hand, in ego orientation the aim pursued is to show that one is the best, i.e., to win, and assessment of one's performance is dependant on comparing oneself with others (Duda, 1992, 1993, 1996; Roberts, 2001).

It has been demonstrated that task goal orientation is associated with greater persistence, more interest, and greater effort (Duda, 1992; Roberts, 2001; Roberts, Treasure & Kavussanu, 1997), that is, there is an increase in subject's level of effort and enjoyment. Likewise, ego goal orientation is associated with greater competitiveness, with greater anxiety during competition, and with somewhat unfavourable attitudes to other competitors (Biddle, 2001; Duda, 2001; Fry, 2001). Moreover, it seems that having one type of goal orientation or another is a consequence of socialisation (at home and at school), and of prior experience in physical and sports activities (Ames, 1992b; Duda, 1992; Duda & Hall, 2001; Roberts, 1984, 2001; Robert *et al.*, 1997). In other words, a subject's goal orientations may largely depend on contextual variables (such as the motivational climate set by the trainer) or personal variables (such as degree of satisfaction with results, beliefs on achieving success or reasons for practising sport).

In this sense, various studies (Baric, 2005; Cervelló & Santos-Rosa, 2001; Duda & Hom, 1993; Kuczka & Treasure, 2005; Noutmanis & Biddle, 1999a, 1999b; Ommundsen & Roberts, 1999; Reinboth & Duda, 2004; Seifriz, Duda & Chi, 1992; Smith, Balaguer & Duda, 2006; Walling, Duda & Chi, 1993) analyse the relations between athletes' goal orientations and perceived motivational climate in parents or trainers. Overall, these studies conclude that athletes who perceive that their trainer promotes a climate of task involvement enjoy themselves and make a greater effort. On the other hand, athletes who perceive that the trainer encourages a climate of ego involvement show greater fear of failure, greater tension, and inadequate feelings of performance.

Other research works study the relationships between goal orientations and sport satisfaction (Balaguer, Duda, Atienza & Mayo, 2002; Duda & Nicholls, 1992; Newton & Duda, 1999; Robert, Treasure & Kavussanu, 1996; Rosich, 2005; Walling, Duda & Crawford, 2002). These studies conclude that task goal orientation is associated with greater interest and satisfaction when athletes experience mastery and obtain greater enjoyment from practising sport. On the other hand, ego goal orientation is associated with greater boredom and less interest, but the satisfaction of achieving normative success.

There are also studies analysing the relationships between athletes' beliefs on the causes of success in sport and goal orientation (Duda & Nicholls, 1992; Navas & Soriano, 2006; Roberts & Ommundsen, 1996; Spray, Biddle & Fox, 1999; White, Kavussanu, Tank & Wingate, 2004). They reveal that task goal orientation is associated with the belief that success in sport is achieved with effort and hard work, while ego goal orientation is associated with the belief that success in sport depends on athletes' skills and cheating.

And, finally, there is research work that studies the relationship between goal orientations and athletes' reasons for practising sport (Castillo, Balaguer & Duda, 2000; Duda & Nicholls, 1992; Papioannou, 1998; Roberts & Ommundsen, 1996; White, Duda & Keller, 1998). In these studies, reasons for practising sport that include: learning, having fun, skill development or keeping in good physical condition are associated with task goal orientation; while reasons for practising sport such as achieving success or good social status are associated with ego goal orientation.

In most of the above research, goal orientations –task or ego– are the independent variables. However, if as Wentzel (1999, 2000) suggested we take into account that goals can stem from either the subject or the context, and that even if a person pursues certain goals the social contexts defines them, then it could make sense to consider how contextual or personal variables determine goal orientations.

For these reasons, in the present study a “causal model” is proposed. In this model, predictive variables refer to the motivational climate, satisfaction with sports results, beliefs on the causes of success in sports, and reasons for practising sport. On the other hand, goal orientations are the variables to predict. The aims of the study are, first, to propose a predictive model of goal orientations, and, second, to subject this model to empirical comparison.

METHOD

Participants

159 women and 352 men ($N=511$) participated in the study. They were all professional athletes practising different sports (handball, basketball, football, volleyball, taekwondo, tennis, karate, cycling, athletics, football hall, rhythmic gymnastics, etc.). They were selected by incidental sampling based on their availability to respond to the study questionnaires. Subjects' mean age was 22.87 years ($\sigma = 5.24$).

Instruments

The questionnaires employed in the study were the following:

1) POSQ: Perception of Success Questionnaire (Roberts, Treasure & Balagué, 1998) is used to evaluate task goal orientation and ego goal orientation. The internal consistency (Cronbach's Alpha) for each subscale was 0.77 and 0.99, respectively.

2) Satisfaction with Sports Results Questionnaire (Treasure & Roberts, 1994a, 1994b) is made up of three subscales: i) mastery experience which expresses subjects' preference for results that report personal progress; ii) social approval which relates to subjects' wish for achieving social recognition; iii) normative success which reflects subjects' preference for results that show that they are more skilled than their competitors. The internal consistency for each subscale was 0.72, 0.87, and 0.58 respectively.

3) PMCSQ-II: Perceived Motivational Climate in Sport Questionnaire (Newton & Duda, 1993a) is comprised of two subscales. The first subscale reflects the perception of a task-involved climate, and the second represents an ego-involved climate. The internal consistency (Cronbach's Alpha) for each subscale was 0.87 and 0.83, respectively.

4) BCSSQ: Beliefs about Causes of Sport Successes Questionnaire (Duda & Nicholls, 1992) is integrated by three factors: i) The motivation-effort factor refers to the belief that success in sport depends on the effort exerted while undertaking the task (with an internal consistency of 0.78). ii) The normative skill factor consists on the belief that success in sport depends on having the necessary skill (with an internal consistency of 0.62). iii) The deceit factor represents the belief that developing deceitful behaviours, such as cheating, is associated with success in sport (with an internal consistency of 0.72).

5) Participation Motivation Inventory (Gill, Gross & Huddleston, 1983). This questionnaire is made up of eight factors corresponding to as many motives for practising a sport. These are the following: energy release or personal satisfaction, status or self-achievement, fitness, team work, skill development, friendship, social factors and fun. The alpha coefficient for the full scale is 0.84.

Variables

- The predictive variables are the following:
- Perceived motivational climate: Task Involvement Climate (TIC) and Ego Involvement Climate (EIC).
- Satisfaction with sports results: Mastery Experience (ME), Social Approval (SA), and Normative Success (NSU).
- Beliefs about achieving success in sport: Motivation-Effort (MO), Normative Skills (NSK), and Deceitful Techniques (DT).
- Reasons for practicing sport: Energy Release or Personal Satisfaction (PS), Status or Self-Achievement (ST), Fitness (FN), Team Work (TW), Skill Development (SD), Social Factors (SF), Friendship (FS) and Fun (FU).

Task Goal Orientations (TASK) and Ego Goal Orientations (EGO) are the variables to predict or dependent variables.

Procedure

Different team trainers and sport clubs collaborated with the questionnaire administration. The aims of the investigation were explained to the athletes during a training session, and they were encouraged to voluntarily participate and individually respond to the questionnaires. They filled in the questionnaires without showing signs of disapproval, taking between 15 and 20 minutes to do so.

Design

The design is basic correlational ex post facto, given that subjects are not randomly selected and that there is no intentional manipulation of variables.

Data Analyses

First, correlational and multiple regression analyses are undertaken on the data. For this purpose the statistical package SPSS is used (version 16.0). And, second, with LISREL (8.71) a causal analysis through path analysis are carried out using maximum likelihood as estimation method.

RESULTS

Regression Analysis

First, in order to analyse which variables, out of those studied, best predict task and ego goal orientation, stepwise multiple regression analyses are used to establish a simple predictive model of goal orientations (task and ego). The predictive variables are those that make reference to: satisfaction with sports results (ME, SA, and NSU), motivational climate (TIC and EIC), beliefs related with achieving success in sport (MO, NSK, and DT), and reasons for practising sport (PS, ST, FN, TW, SD, SF, FS and FU).

Regression analyses results are summarised in table 1. As can be seen, for task goal orientation, the predictor variables entered into the equation, with statistically significant t probability ($p \leq 0.046$), are: Mastery Experience (ME), Normative Success (NSU), Task Involvement Climate (TIC), Motivation-Effort (MO), Skill Development (SD), and Friendship (FS). Overall, these variables account for 48.9% of the variance ($R^2=0.489$).

Also, in table 1, it can be seen that when the criterion variable is ego goal orientation, the predictor variables entered into the regression equation, with t values associated to statistically significant probabilities ($p \leq 0.034$), are: Social Approval (SA), Normative Success (NSU), Ego Involvement Climate (EIC), Deceitful Techniques (DT), Normative Skills (NSK), Status or Self-Achievement (ST), Team Work (TW), and Social Factors (SF). These variables justify 51.9% of the variance in the criterion variable ($R^2=0.519$).

It is therefore inferred that to predict task goal orientation, the predictor variables are: Mastery Experience (ME), Normative Success (NSU), Task Involvement Climate (TIC), Motivation-Effort (MO), Skill Development (SD), and Friendship (FS). In ego goal orientation, the predictor variables are: Social Approval (SA), Normative Success (NSU), Ego Involvement Climate (EIC), Normative Skill (NSK), Status or Self-

Achievement (ST); and in a negative direction: Deceitful Techniques (DT), Team Work (TW), and Social Factors (SF).

Table 1. Stepwise multiple regression analyses to establish explanatory-predictive models of Goal Orientations (TASK and EGO). Predictor variables are those relating to Satisfaction with Sport Results, Motivational Climate, Beliefs about Achieving Success in Sport, and Reasons for Practicing Sport.

Criterion	Predictors	<i>t</i>	<i>p</i>	β
Task goal orientation (TASK) $R^2=0.489$ <i>E.E. R^2=0.472</i>	ME	5.814	0.000*	0.249
	SA	1.845	0.066	0.068
	NSU	2.002	0.046	0.085
	TIC	5.793	0.000*	0.223
	EIC	-0.724	0.469	-0.028
	MO	5.871	0.000*	0.264
	DT	-0.911	0.363	-0.038
	SKN	-0.019	0.985	-0.001
	PS	-1.145	0.253	-0.048
	ST	-0.921	0.357	-0.039
	FN	1.089	0.277	0.043
	TW	-0.946	0.345	-0.033
	SD	2.193	0.029*	0.080
	SF	0.429	0.668	0.017
	FS	2.173	0.030*	0.100
FU	-1.014	0.311	-0.049	
Ego goal orientation (EGO) $R^2=0.519$ <i>E.E. R^2=0.503</i>	ME	0.130	0.897	0.005
	SA	2.544	0.011*	0.091
	NSU	6.793	0.000*	0.281
	TIC	0.208	0.836	0.008
	EIC	3.991	0.000*	0.149
	MO	-0.059	0.953	-0.003
	DT	-2.121	0.034*	-0.085
	SKN	6.861	0.000*	0.292
	PS	-1.767	0.078	-0.071
	ST	7.260	0.000*	0.297
	FN	1.753	0.080	0.066
	TW	-2.424	0.016*	-0.083
	SD	0.417	0.677	0.015
	SF	-2.325	0.020*	-0.087
	FS	0.134	0.893	0.006
FU	0.161	0.872	0.008	

(ME= Mastery Experience; SA= Social Approval; NSU= Normative Success; TIC= Task Involvement Climate; EIC= Ego Involvement Climate; MO= Motivation-Effort; NSK= Normative Skills; DT= Deceitful Techniques; PS= Energy Release or Personal Satisfaction; ST= Status or Self-Achievement; FN= Fitness; TW= Team Work; SD= Skill Development; SF= Social Factors; FS= Friendship; FU= Fun).

Path Analyses

These results, together with a review of the state of current research that is summarised in the introduction, are the starting point to propose a joint causal model of the variables under study, understood from a statistical control approach and not a deterministic perspective (Bollen, 1989). Current regression analyses results inform us which variables influence dependent variables, but we know nothing about how they are related. The purpose is therefore to establish a causal diagram of how the independent variables affect task and ego goal orientations. Predictor variables that best explain the

dependent variables and that carry greater weight in predicting scores in both goal orientations are taken as reference.

From the set of variables considered, and based on the simplest possible model, the predictor variables are: Mastery Experience (ME), Task Involvement Climate (TIC), Motivation-Effort (MO), Normative Success (NSU), Ego Involvement Climate (EIC), Status or Self-Achievement (ST); and Task Goal Orientation (TASK) and Ego Goal Orientation (EGO) are the criterion variables. The matrix of correlations between predictor variables is summarised in table 2.

Table 2. Correlation matrix between predictor variables of the model

	ME	TIC	MO	NSU	EIC	ST
ME	-	0.413**	0.588**	0.320**	-0.071	0.122**
TIC	-	-	0.456**	0.185**	-0.249**	0.010
MO	-	-	-	0.311**	-0.145**	0.058
NS	-	-	-	-	0.203**	0.357**
EIC	-	-	-	-	-	0.319**
ST	-	-	-	-	-	-

* $p < 0.05$; ** $p < 0.01$

(ME= Mastery Experience; TIC= Task Involvement Climate; EIC= Ego Involvement Climate; MO= Motivation-Effort; NSU= Normative Success; ST= Status or Self-Achievement).

Figure 1 offers the results of the completely standardised solution based on the structural model established for goal orientations. The model obtains a $\chi^2 = 38.44$ (DF.=28; $p=0.09$), and a value for the *Root Mean Square Error of Approximation* (RMSEA) of 0.0028, indicating that it adequately represents the way the variables included in the model relate to each other. As can be observed in Figure 1, the predictor variables Mastery Experience (ME), Task Involvement Climate (TIC), and Motivation-Effort (MO) are positively related with Task Goal Orientation (TASK) with values of 0.28, 0.25, and 0.31, respectively. While the variables Normative Success (NSU), Ego Involvement Climate (EIC) and Status or Self-Achievement (ST) are positively related with Ego Goal Orientation (EGO) with values of 0.50, 0.26, and 0.03, respectively.

Analysis of modification indices show that the model would greatly improve if the two dependent variables are related (TASK and EGO). χ^2 increases 29.86 for 1 degree of freedom ($p=0.000$), and the probability of accepting the null hypothesis of the model that includes this relation is 1.00. The results obtained in the causal model when the modification indices are included are shown in figure 2.

Figure 1. Path diagram for Goal Orientations (TASK and EGO)

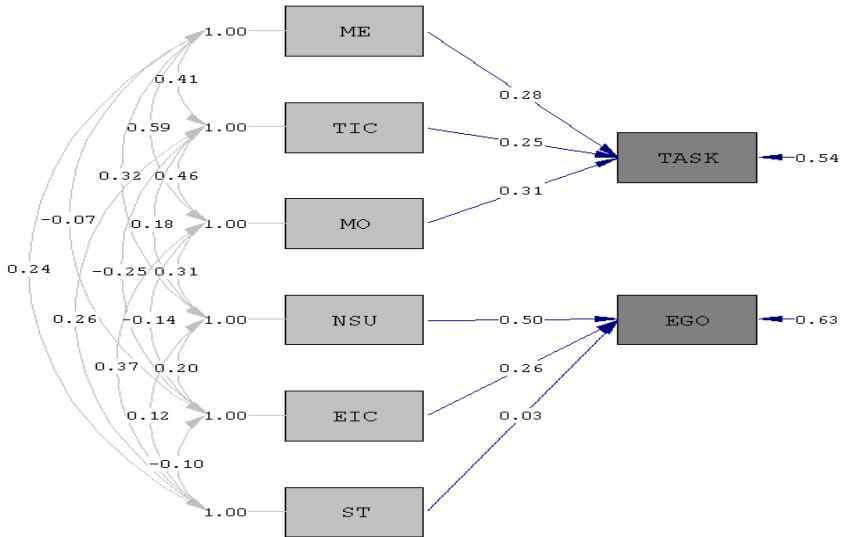
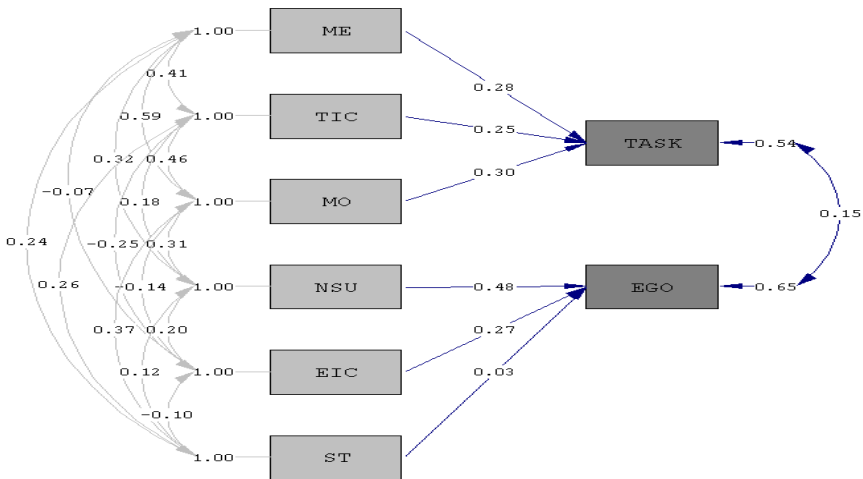

Figure 2. Path diagram for Goal Orientations (TASK and EGO) including modification index



In table 3, we presents fit indices for the goal orientations model, task and ego, with and without the modification indices, as they help validate the proposed structure for the “causal” model, given that the fit indices are adequate.

Table 3. Fit indices for Goal Orientations (TASK and EGO) including modification indices

CAUSAL MODEL OF GOAL ORIENTATIONS	FIT INDICES						
	χ^2	<i>g.l</i>	PECVI	(ΔX^2)	$(\Delta g.l.)$	RMSEA	GFI
Model (TASK and EGO)	38.44	28	0.09			0.028	0.98
Model (TASK and EGO) with modification indices	8.58	27	1.00	29.86	1	0.000	1.00

DISCUSSION

The aim of the present study was to analyse the possible influence of contextual variables, such as motivational climate, and of personal variables, such as satisfaction with sport results, beliefs related with achieving success in sport and reasons for practising sport on athletes goal orientations.

The result obtained in the multiple regression analyses allow us to conclude, first, that for task goal orientation, the predictor variables are: mastery experience, normative success, task involvement climate, motivation-effort, skill development and friendship. These variables account for nearly half of the explained variance. Second, that for ego goal orientation, the predictor variables are social approval, normative success, ego involvement climate, deceitful techniques, normative skill, status or self-achievement, team work, and social factors. Between these variables, more than half of the explained variance is accounted for.

Based on these results, a causal model is proposed and analysed through structural equations modelling. The model has an adequate fit, and the results confirm the effects of variables involving satisfaction with sports results, motivational climate, beliefs related to achieving success in sports, and reasons for practising sport on the athletes' goal orientations.

It therefore seems that athletes who find satisfaction experiencing mastery, who perceive in the motivational climate in which they are immersed that hard work is rewarded, and who believe that success depends on their effort, will develop a task goal orientation, which in turn is consistent with the findings from other studies (Castillo, Balaguer & Duda, 2002; Duda, Fox, Biddle & Armstrong, 1992; Duda & White, 1992; Guivernau, Thorne & Duda, 1994; Kavussanu & Roberts, 1996; Newton & Duda, 1993b; Roberts & Ommundsen, 1996; Treasure & Roberts, 1994a; White & Duda, 1993). However, athletes who find satisfaction showing greater skill than the others, who perceive a motivational climate that leads them to surpass each other, and in which the trainer punishes those who make mistakes and rewards only the best players, and what motivates them when practising sport is to achieve certain social status and be popular, will have an ego goal orientation, which is in line with conclusions from other research work (Duda & Nicholls, 1992; Guivernau & Duda, 1995; Hom, Duda & Miller, 1993;

Lochbaum & Roberts, 1993; Nyheim, Kavussanu, Roberts & Treasure, 1996; Roberts *et al.*, 1996; Theodosiu & Papaioannou, 2006; Walling & Duda, 1995).

Since the analysis of modification indices indicates that the fit of the model improves substantially if the two goal orientations, task and goal, are interrelated, this may be interpreted as evidence that both variables are oblique as Nicholls (1989) claimed. This means that the two goal orientations do not appear to be dichotomous or independent, as some authors, for example Dweck & Legget (1988), maintained in academic contexts, but to be interrelated. Like Roberts (2001) pointed out “*a person can be high or low in either or both at the same time*” (p. 18).

On the other hand, the fact that it is possible to explain goal orientations from the abovementioned variables is yet more evidence of its construct validity, and indeed refutes the critical arguments put forth by Harwood, Hardy & Swain (2000), both with respect to the assessment procedure and at a conceptual level.

Given that it seems to be proven that athletes’ goal orientations depend on: the perceived motivational climate, their beliefs about achieving success in sport, satisfaction with results, and the reasons for practising sport, and given that task goal orientation seems to generate a more adaptive behaviour in athletes (Biddle, 2001; Duda, 2001; Fry, 2001; Holgado, Navas, López y García, 2010), a practical application that is drawn from this study is that intervention must target athletes obtaining satisfaction through experiencing mastery, establishing a motivational climate in which personal effort and hard work are considered important to obtain reward, and generating the belief that effort leads to success.

However, these results must be considered with caution due to, on the one hand, the incidental sampling method used to select participants, and, on the other, the data collection technique employed, as in their responses participants may have incurred in ego defensive bias or in social desirability bias.

Finally, it is necessary to take into account that, although structural equation models have frequently been used to study causal relations, it is wrong to assume that predictor variables of causal models with a good goodness of fit produce causality. Rather, the aim is to determine if the researcher’s causal inferences are consistent with the data obtained and, as a result, it is only possible to conclude that the model under study can’t be rejected, but that does not imply that many other models can also, quite probably, show a good goodness of fit to the data (Bollen, 1989). It may therefore be relevant to continue investigating in this line of work that considers goal orientations as the dependent variables.

Acknowledgements

The translate of this study have been supported by the *Vicerrectorado de Investigación UNED* as part of the Research Promotion Plan.

REFERENCES

- Ames, C. (1984). Competitive, cooperative, and individualistic goal structures: A motivational analysis. In R. Ames and C. Ames (Eds.), *Research on motivation in education: Student motivation* (pp. 177-207). New York: Academic Press.
- Ames, C. (1992a). Achievement goals and the classroom motivational climate. In J. Meece & D. Schunk (Eds.), *Student's perceptions in the classroom: Causes and consequences* (pp. 327-348). Hillsdale, NJ: Erlbaum.
- Ames, C. (1992b). Achievement goals, motivational climate, and motivational processes. In G.C. Roberts (Ed.), *Motivation in sport and exercise* (pp. 161-176). Champaign, IL: Human Kinetics.
- Balaguer, I., Duda, J., Atienza, F. & Mayo, C. (2002). Situational and dispositional goals as predictors of perceptions of individual and team improvement, satisfaction and coach ratings among elite female handball teams. *Psychology of Sport and Exercise*, 3(4), 293-308.
- Baric, R. (2005). Motivational climate in sports teams: Situational vs. dispositional determinants. *Drustvena Istrazivanja*, 14(4-5), 783-805.
- Biddle, S.J.H. (2001). Enhancing motivation in physical education. In G.C. Roberts (Ed.), *Advances in motivation in sport and exercise* (pp. 51-78). Champaign, IL: Human Kinetics.
- Bollen, K. (1989). *Structural Equations with Latent Variables*. New York: John Wiley.
- Castillo, I., Balaguer, I. & Duda J.L. (2000). Las orientaciones de meta y los motivos de práctica deportiva en los jóvenes deportistas valencianos escolarizados. *Revista de Psicología del Deporte*, 9(1), 37-50.
- Castillo, I., Balaguer, I. & Duda, J.L. (2002). Goals perspectives of adolescents in sport context. *Psicothema*, 14(2), 280-287.
- Cervelló, E. & Santos Rosa, F.J. (2001). Motivation in Sport: An achievement goal perspective in Spanish recreational athletes. *Perceptual and Motor Skills*, 92, 527-534.
- Duda, J.L. (1992). Motivation in sport settings: A goal perspective approach. In G.C. Roberts (Ed.), *Motivation in sport and exercise* (pp. 57-91). Champaign, IL: Human Kinetics.
- Duda, J.L. (1993). Goals: A social-cognitive approach to the study of achievement motivation in sport. In R.N. Singer, M. Murphey & L.K. Tennant (Eds.), *Handbook of research on sport psychology* (pp. 421-436). New York: Macmillan.
- Duda, J.L. (1996). Maximizing motivation in sport and physical education among children and adolescents: The case for greater task involvement. *Quest*, 48, 290-302.
- Duda, J.L. (2001). Goals perspectives research in sport: pushing the boundaries and clarifying some misunderstandings. In G. C. Roberts (Ed.), *Advances in motivation in sport and exercise* (pp. 306-329). Champaign, IL: Human Kinetics.
- Duda, J.L., Fox, K.R., Biddle, S.J.H. & Armstrong, N. (1992). Children's achievement goals and beliefs about success in sport. *British Journal of Educational Psychology*, 62, 313-323.
- Duda, J.L. & Hall, H. (2001). Achievement goal theory in sport. In R.N. Singer, H.A. Hausenblas & C.M. Janelle (Eds.), *Handbook of sport psychology* (pp. 417-443). New York: Wiley.
- Duda, J.L. & Hom, H.L. (1993). Interdependencies between the perceived and self-reported goal orientations of young athletes and their parents. *Paediatric Exercise Science*, 5(3), 234-241.
- Duda, J.L. & Nicholls, J.G. (1992). Dimensions of achievement motivation in school-work and sport. *Journal of Educational Psychology*, 84(3), 290-299.

- Duda, J.L. & White, S.A. (1992). Goal orientations and beliefs about the causes of sport success among elite skiers. *The Sport Psychologist*, 6(4), 334-343.
- Dweck, C.S. (1986). Motivational processes affecting learning. *American Psychologist*, 41, 1040-1048.
- Dweck, C.S. & Elliot, E.L. (1983). Achievement motivation. In E.M. Hetherington (Ed.), *Handbook of child psychology. Socialization, personality and social development* (pp. 643-691). New York: Wiley.
- Dweck, C.S. & Legget, E. (1988). A social-cognitive approach to motivation and personality. *Psychology Review*, 95, 256-273.
- Fry, M.D. (2001). The development of motivation in children. In G.C. Roberts (Ed.), *Advances in motivation in sport and exercise* (pp. 51-78). Champaign, IL: Human Kinetics.
- Gill, D.L., Gross, J.B. & Huddleston, S. (1983). Participation motivation in youth sports. *International Journal of Sport Psychology*, 14, 1-14.
- Guivernau, M. & Duda, J.L. (1995). Psychometric properties of a Spanish version of the Task and Ego Orientation in Sport Questionnaire (TEOSQ) and Beliefs about the Causes of Success Inventory. *Revista de Psicología del Deporte*, 5, 31-51.
- Guivernau, M., Thorne, K. & Duda, J.L. (1994). Cross domain generality of goals, beliefs, perceived ability and interest: A replication. Paper presented at the 4th Annual Midwest Sport and Exercise Psychology Symposium, Michigan State University, East Lansing.
- Harwood, C., Hardy, A. & Swain, A. (2000). Achievement goals in sport: A critique of conceptual and measurement issues. *Journal of Sport and Exercise Psychology*, 22, 235-255.
- Holgado, F.P., Navas, L., López, M. y García, T. (2010). A structural model of goal orientation in sports: Personal and contextual variables. *The Spanish Journal of Psychology*, 13(1), 256-265.
- Hom, H.L., Duda, J.L. & Miller, A. (1993). Correlates of goal orientations among young athletes. *Paediatric Exercise Science*, 5(2), 168-176.
- Kavussanu, M. & Roberts, G.C. (1996). The utility of dispositional versus situational factors in predicting intrinsic motivation, beliefs about the causes of success, and task choice in physical activity classes. *Journal of Sport and Exercise Psychology*, 18(3), 46-61.
- Kuczka, K. & Treasure, D. (2005). Self-handicapping in competitive sport: Influence of the motivational climate, self-efficacy, and perceived importance. *Psychology of Sport and Exercise*, 6(5), 539-550.
- Lochbaum, M. & Roberts, G.C. (1993). Goal orientations and perceptions of the sport experience. *Journal of Sport and Exercise Psychology*, 15, 160-171.
- Navas, L. & Soriano, J.A. (2006). Metas, atribuciones y sus relaciones en las clases de Educación Física. *Infancia y Aprendizaje*, 29(4), 411-421.
- Newton, M. & Duda, J.L. (1993a). The Perceived Motivational Climate in Sport Questionnaire: Construct and Predictive Utility. *Journal of Sport and Exercise Psychology*, 15, S56.
- Newton, M. & Duda, J.L. (1993b). The relationship of task and ego orientation to performance-cognitive content, affect, and attributions in bowling. *Journal of Sport Behavior*, 16(4), 209-220.
- Newton, M. & Duda, J.L. (1999). The interaction of motivational climate, dispositional goal orientation, and perceived ability in predicting indices of motivation. *International Journal of Sport Psychology*, 30, 63-82.
- Nicholls, J.G. (1984). Conceptions of ability and achievement motivation. In R. Ames & C. Ames (Eds.), *Research on motivation in education: Student motivation* (pp. 39-73). New York: Academic Press.
- Nicholls, J.G. (1989). *The competitive ethos and democratic education*. Cambridge, MA: Harvard University Press.

- Noutmanis, N. & Biddle, S. (1999a). Affect and achievement goals in physical activity: A meta-analysis. *Scandinavian Journal of Medicine and Science in Sports*, 9, 315-332.
- Noutmanis, N. & Biddle, S. (1999b). A review of motivational climate in physical activity. *Journal of Sport Sciences*, 17, 643-665.
- Nyheim, M., Kavussanu, M., Roberts, G.C. & Treasure, D.C. (1996). Goal orientations, beliefs about success and satisfaction in summer sports camp participation. Paper presented at the *Annual Conference of the North American Society for the Psychology of Sport and Physical Activity*, Ontario, Canada.
- Ommundsen, Y. & Robert, G.C. (1999). Effect of motivational climate profiles on motivational indices in team sport. *Scandinavian Journal of Medicine and Science in Sports*, 9, 389-397.
- Reinboth, M. & Duda, J. (2004). The motivational climate, perceived ability and athletes' psychological and physical well-being. *Sport Psychologist*, 18(3), 237-251.
- Roberts, G.C. (1984). Achievement motivation in children's sports. In J.G. Nicholls (Ed.), *Advances in motivation and achievement. The development of achievement motivation* (pp. 251-281). Greenwich, CT: JAI Press.
- Roberts, G.C. (1992). *Motivation in sport and exercise*. Champaign, IL: Human Kinetics.
- Roberts, G.C. (2001). Understanding the dynamics of motivation in physical activity: The influence of achievement goals on motivational processes. In G.C. Roberts (Ed.), *Advances in motivation in sport and exercise* (pp. 1-50). Champaign, IL: Human Kinetics.
- Roberts, G.C. & Ommundsen, Y. (1996). Effect of goal orientations on achievement beliefs, cognitions and strategies in team sport. *Scandinavian Journal of Medicine and Science in Sport*, 6, 46-56.
- Roberts, G.C., Treasure, D.C. & Balagué, G. (1998). Achievement goals in sport: The development and validation of the Perception of Success Questionnaire. *Journal of Sports Sciences*, 16, 337-347.
- Roberts, G.C., Treasure, D.C. & Kavussanu, M. (1996). Orthogonality of achievement goals and its relationship to beliefs about success and satisfaction in sport. *The Sport Psychologist*, 10(4), 398-408.
- Roberts, G.C., Treasure, D.C. & Kavussanu, M. (1997). Motivation in physical activity contexts: An achievement goal perspective. In P. Pintrich & M. Maehr (Eds.), *Advances in motivation and achievement* (pp. 413-447). Stamford, CT: JAI Press.
- Rosich, M. (2005). Estudio sobre la percepción de satisfacción en el deporte en el ámbito competitivo en una muestra de universitarios. *Memoria del X Congreso Nacional y Andaluz de Psicología de la Actividad Física y el Deporte* (pp. 632-641). Málaga, España.
- Seifriz, J., Duda, J.L. & Chi, L. (1992). The relationship of perceived motivational climate to intrinsic motivation and beliefs about success in basketball. *Journal of Sport and Exercise Psychology*, 14, 375-391.
- Smith, A., Balaguer, I. & Duda, J. (2006). Goal orientation profile differences on perceived motivational climate, perceived peer relationships, and motivation-related responses of youth athletes. *Journal of Sports Sciences*, 24(12), 1315-1327.
- Spray, C.M., Biddle, S.J.K. & Fox, K.R. (1999). Achievement goals, beliefs about the causes of success and reported emotion in post 16 physical education. *Journal of Sports Sciences*, 17, 213-219.
- Theodosiu, A. & Papaioannou, A. (2006). Motivational climate, achievement goals and metacognitive activity in physical education and exercise involvement in out of school settings. *Psychology of Sport and Exercise*, 7(4), 361-379.

- Treasure, D.C. & Roberts, G.C. (1994a). Cognitive and affective concomitants of task and ego goal orientations during the middle school years. *Journal of Sport and Exercise Psychology*, 16(1), 15-28.
- Treasure, D.C. & Roberts, G.C. (1994b). Perception of Success Questionnaire: Preliminary validation in an adolescent population. *Perceptual and Motor Skills*, 79, 607-610.
- Walling, M.D. & Duda, J.L. (1995). Goals and their associations with beliefs about success in and perceptions of the purposes of physical education. *Journal of Teaching in Physical Education*, 14(2), 140-156.
- Walling, M. L., Duda, J. L. & Chi, L. (1993). The perceived motivational climate in sport questionnaire: Construct and predictive validity. *The Journal of Sport and Exercise Psychology*, 15, 172-183.
- Walling, M.D., Duda, J.L. & Crawford, T. (2002). Goal orientations, outcome and responses to youth competition among high/low perceived ability athletes. *International Journal of Sport Psychology*, 14, 140-156.
- Wentzel, K.R. (1999). Social-motivational processes and interpersonal relationships: Implications for understanding students' academic success. *Journal of Educational Psychology*, 91, 76-97.
- Wentzel, K.R. (2000). What is it that I'm trying to achieve? Classroom goals from a content perspective. *Contemporary Educational Psychology*, 25, 105-115.
- White, S.A. & Duda, J.L. (1993). Dimensions of goals and beliefs among adolescent athletes with physical disabilities. *Adapted Physical Activity Quarterly*, 10(2), 125-136.
- White, S.A., Duda, J.L. and Keller, M.R. (1998). The relationship between goal orientation and perceived purposes of sport among youth sport participants. *Journal of Sport Behavior*, 21(4), 474-483.
- White, S., Kavussanu, M., Tank, K. & Wingate, J. (2004). Perceived parental beliefs about the causes of success in sport: Relationship to athletes' achievement goals and personal beliefs. *Scandinavian Journal of Medicine and Science in Sports*, 14(1), 57-66.

Received April, 21, 2009

Revision received September, 20, 2009

Accepted September, 26, 2009