

Polarization studies in a computer based laboratory



Amit Garg, Reena Sharma, Vishal Dhingra
Acharya Narendra Dev College, University of Delhi
Govindpuri, Kalkaji, New Delhi-110019, India.

E-mail: amit_andc@yahoo.co.in

(Received 1 December 2010; accepted 16 March 2011)

Abstract

This didactic activity is based on computer based learning through sensors and advanced tools for data acquisition and analysis. The fundamental studies related to polarization namely Malus' Law and study of elliptical and circular polarization have been automated using rotary motion and light sensor. This computer based laboratory allows a student to online collect, analyze and display the data during experimentation leading to better understanding of otherwise a very difficult concept of polarization. Also, time required for carrying out the study of elliptical and circular polarization is substantially reduced from 3 hours to less than half an hour.

Keywords: LabVIEW, Polarization, Automation Optics Laboratory.

Resumen

Esta actividad didáctica se utiliza equipo basado en el aprendizaje a través de sensores y herramientas avanzadas para la adquisición de datos y análisis. Los estudios fundamentales relacionados con la polarización a saber, la Ley Malus' y el estudio de la polarización elíptica y circular se han automatizado usando un movimiento rotatorio y sensor de luz. Este laboratorio informático permite a un estudiante ponerse en línea, analizar y mostrar los datos durante la experimentación teniendo así una mejor comprensión de lo contrario el concepto de polarización resultaría muy difícil. Además, el tiempo necesario para llevar a cabo el estudio de la polarización elíptica y circular se reduce sustancialmente de 3 horas a menos de media hora.

Palabras clave: LabVIEW, Polarization, Automatización del Laboratorio de Óptica.

PACS: 01.50.Lc, 01.50.Pa, 07.05.-t

ISSN 1870-9095

I. INTRODUCTION

Over the last few years, there has been a substantial increase in the use of sensors, data acquisition and analysis tools in almost every science laboratory [1, 2, 3, 4, 5, 6, 7, 8, 9, 10, 11, 12, 13, 14]. These tools have been instrumental in bridging the gap between various theoretical concepts taught in the class and the experimental skills. Automated data acquisition and analysis allows undergraduate students to focus entirely on the experiment and on its underlying physics rather than spending most of the time collecting and plotting data for later analysis. This way, students are able to generate experimental data, draw graphs, re-examine the variables and identify possible errors as well as running the experiment again, if necessary, during class. As reported by Hsu *et al.* [5] for refractive index measurements, they have used a computer-based filtering procedure of the experimental reflectance during the data acquisition process for increasing the precision of the measurements to 0.001° at any angle of incidence. Garg *et al.* [2] has reported the development of an automated system for energy bandgap and resistivity measurement of a semiconductor sample using Four-Probe method for use in the undergraduate

laboratory of Physics and Electronics students. This automated data acquisition and analysis system has been developed using National Instruments USB-6008 DAQ Card and Student version of LabVIEW 8.5.

Polarization is considered as one of the difficult topics in optics. Some earlier studies report various polarization based studies [5, 7, 8, 14]. The present development is an attempt to ease the polarization studies through sensors and data acquisition and analysis tools. In this work, we have investigated the Malus' Law along with two types of polarization namely circular and elliptical polarization. The rotary motion and light sensor are connected to a data acquisition device sensorDAQ which in turn is connected to PC. The software application has been developed using student version of LabVIEW 8.5.

II. THEORY

A. Polarization of Light

Light can be described as an electromagnetic wave that, like radio waves, propagates via a sinusoidal oscillation of an

electric field. The direction in which the electric field oscillates as it propagates is known as the polarization. The simplest type is linear or plane polarization, illustrated in Fig. 1 for an optical signal traveling through free space, in which the field of the optical signal oscillates only in a single fixed plane. The vector along which the light travels must also lie in this plane, but this restriction still allows an infinite number of planes of polarization to be defined, each of which describes a separate linear state of polarization (SOP).

In order to meaningfully specify the polarization of an optical signal, we must first define some physical reference. This might be one of the crystalline axes in the laser source that serves as a source of light, or possibly a reference line on one of the components in an optical system. Whatever reference we choose will then define a set of axes, which provides a basis for specifying every possible SOP. Fig. 2 shows a bulk optical crystal with a laser beam incident on one face.

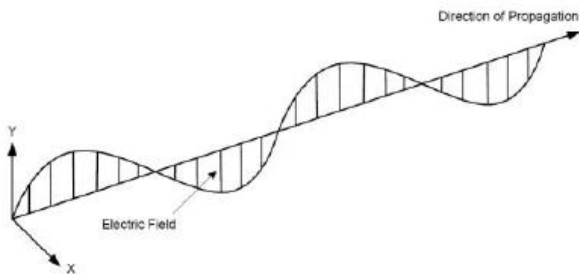

FIGURE 1. Linear Polarization.

We have decided to choose the horizontal crystal axis as a reference, since it coincides with one of the Principal States of Polarization (PSP) for the crystal - those SOP's which are invariant for slight changes in launched signal wavelength. We label the horizontal axis "x", and the orthogonal vertical crystal axis, "y". As in the Fig. 2, the polarization of the incident laser beam is linear and oriented at 45° to the x- and y-axes. In our reference frame, this polarization state equivalently resolves into two linear polarization states, each of which lies along one of the crystal axes.

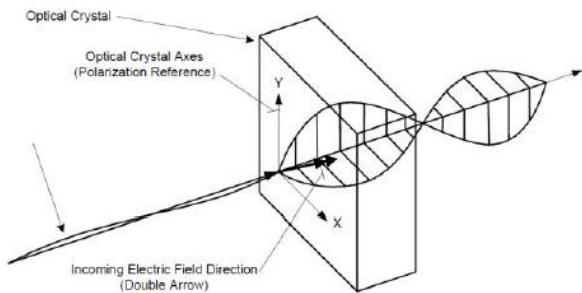

FIGURE 2. Plane polarized light resolved into two new states of linear polarization.

Birefringence is a property of optical materials for which light that is polarized along the x axis experiences a different index of refraction, and therefore travels at a different speed than does light polarized along the y axis. If the length of an optical crystal is just such that, with the difference in speed of propagation, the x-polarized light arrives one quarter wavelength ahead of (or behind) the y-polarized light, the crystal is known as a quarter wave plate. An interesting thing happens when we pass linearly-polarized light through a quarter wave plate at 45° to its axes, as shown in Fig. 3. If we track the electric field of the propagating wave, it appears that the field is rotating in a circle as the wave propagates. For this reason, this type of field configuration is described as circularly polarized. Circularly polarized light consists of two perpendicular electromagnetic plane waves of equal amplitude and 90° difference in phase. In fact, depending on the relative magnitude of the x- and y-polarized components and the phase difference between them; we can see a continuum of different states varying from linear to circular, with intermediate states being described as having elliptical polarization.

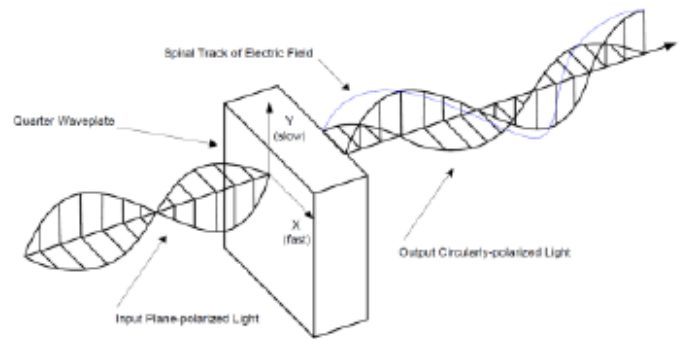

FIGURE 3. Linear to circularly polarized light conversion by quarter wave plate.

If two plane waves of differing amplitude are related in phase by 90°, or if the relative phase is other than 90° then the light is said to be elliptically polarized. Furthermore, with elliptical or circular polarization, the field can rotate either to the left or to the right as the light propagates [15, 16]. Fig. 4 shows all the three types of polarization.

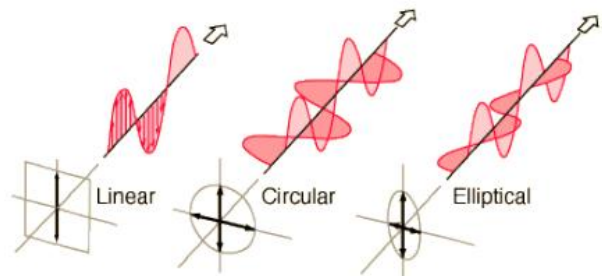

FIGURE 4. Linear, circular and elliptical polarization.

B. Malus' Law

When unpolarized light is incident on an ideal polarizer, the intensity of the transmitted light is one-half of the incident light. If a diode laser is used as the light source, since its light is already polarized, so most of the light will pass through a polarizer oriented with its axis of polarization parallel to that of the laser. If the light is transmitted through the second analyzer, polarizer, which is rotated by an angle of 90° of polarization from that of the first, in this case no light will be transmitted. In the case, where the second polarizer is placed parallel to the first polarizer, the angle of polarization is 0° with respect to the first, essentially all of the light will be transmitted. If θ is the angle difference between the direction of polarization of the light incident out the analyzer and the direction transmitted by the analyzer, the component of the electric field transmitted will be proportional to $\cos\theta$, as shown in Fig. 5. Since the intensity of the light is proportional to magnitude of the electric field squared, the intensity of light transmitted by the analyzer is given by:

$$I(\theta) = I_0 \cos^2 \theta, \quad (1)$$

where I_0 is the maximum intensity transmitted when $\theta = 0$. This is known as Malus' Law [14].

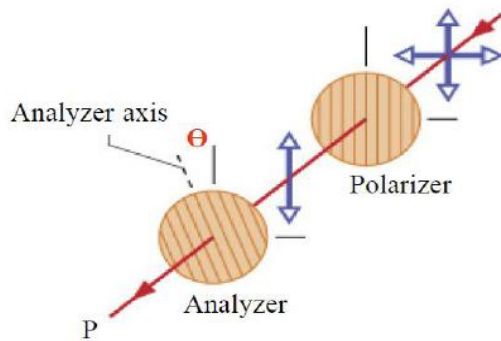

FIGURE 5. Malus' Law.

III. EXPERIMENTAL SETUPS AND RESULTS

A. Malus' law

The experimental setup for verifying the Malus' law is as shown in Fig. 6(a). The setup consists of a He-Ne laser, a set of polarizer and analyzer, a rotary sensor, light sensor, sensorDAQ and a computer. The arrangement was setup on an optical breadboard with all the optical components aligned and firmly fixed. The rotary motion sensor was set at 1440 divisions per rotation and was coupled to the analyzer through a pulley that has the linear calibration i.e. one complete rotation of the analyzer corresponds to 360° through rotary sensor. The sample rate was set to 45 kHz.

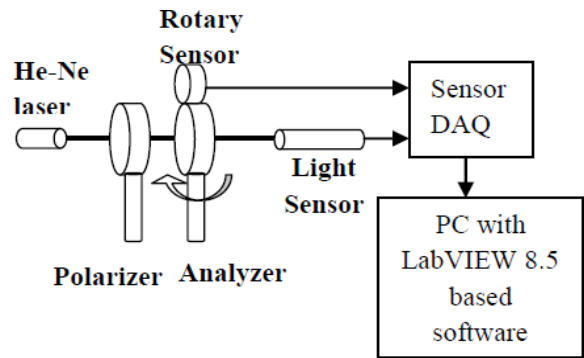

FIGURE 6(a). Experimental setup for verification of Malus' law.

The measurements in the experiment were done by initially positioning the polarizer and analyzer at 0° and then analyzer was rotated through 0° to 360° . One can rotate either of the polarizer or analyzer. The relative intensity of light beam that passes through two polarizers was measured by the light sensor. The rotary motion sensor measures the angle that was obtained from rotating the analyzer relative to the first polarizer. The rotary motion sensor and the light sensor were connected to digital and analog input channels of the sensorDAQ respectively. The programme developed in LabVIEW version 8.5 records and displays in the computer the light intensity and the angle between the axis of polarizers. The developed programme also plots the light intensity with respect to the angle, the cosine of the angle, and the cosine² of the angle. The results are as shown in Fig. 6(b).

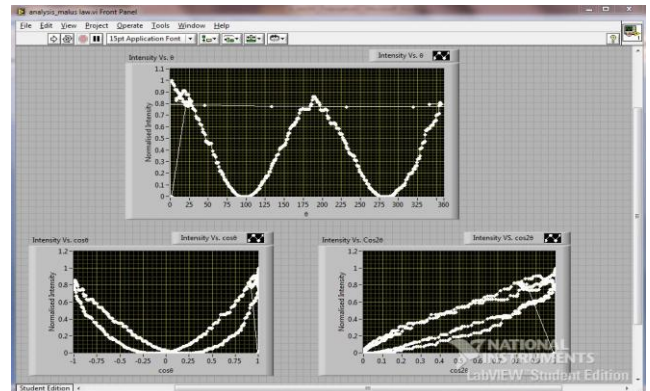

FIGURE 6(b). Graph1: Light intensity vs. θ Graph 2 Light intensity vs. $\cos\theta$ Graph 3 Light intensity vs. $\cos^2\theta$.

As can be seen from the second graph, the intensity of polarized light is maximum almost at -1 and +1 corresponding to $\cos(180^\circ)$ and $\cos(0^\circ)$ respectively. The minimum of polarized light intensity is nearly zero corresponding to $\cos(90^\circ)$. The curve fitting yields the polynomial equation $(ax^2 + bx + c)$ with values of the curve fitting parameters as $a = 0.8598, b = 0.0628, c = -0.0050$. The plot of the intensity of light versus the cosine² of the angle

between the two polarizers as shown by graph 3, demonstrates perfectly the predicted relationship of Malus' law. The plotted data has a linear regression having of a slope, $m = 0.843$ and a correlation coefficient of 0.998. The uncertainty in the slope was within 0.2% of unity. The curve fit for the polynomial function indicates that the light intensity varies as the square of the $\cos \theta$ thus verifying the Malus' law.

A. Elliptical and Circular Polarization

The experimental setup for studying the elliptical and circular polarization is as shown in Fig. 7(a). The setup is identical to what is described for Malus' law with the following exceptions:

1. A quarter waveplate has been introduced in between the polarizer and analyzer.
2. A rotary sensor is coupled to the polarizer for measuring its angular rotation.

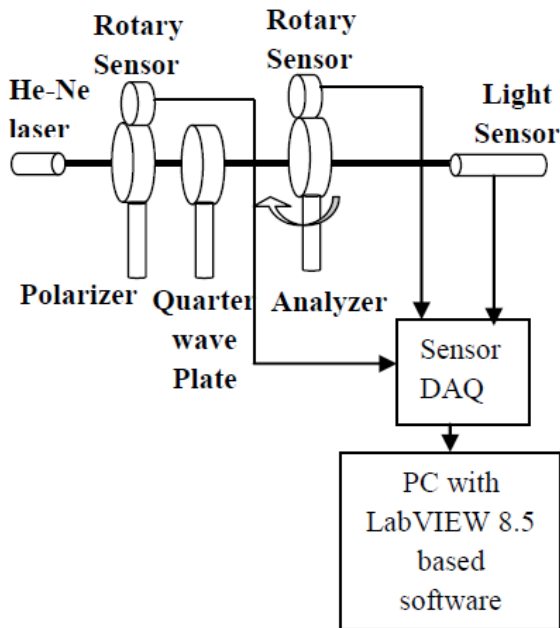

FIGURE 7(a). Experimental setup for study of elliptical and circular polarization.

The experiment was performed by initially positioning the polarizer and the analyzer at 0° . Then for each position of the polarizer between 0° to 90° , analyzer was rotated in steps of 10° from 0° - 360° . The programme developed in LabVIEW version 8.5 records and displays in the computer the light intensity vs. angle of the analyzer on a polar graph for different angles of the polarizers. The sample results are as shown in Fig. 7(b) and 7(c). It can be seen that the light is circularly polarized when the angle of the analyzer is near to 45° (Fig. 7(c)) otherwise it is elliptically polarized as recorded for other angular values of the polarizer. The observations are in line with the theoretical predictions.

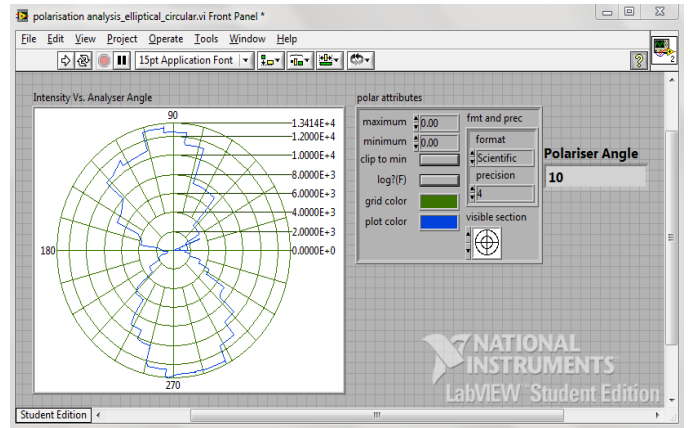

FIGURE 7(b). Intensity vs. θ variation showing elliptical polarization.

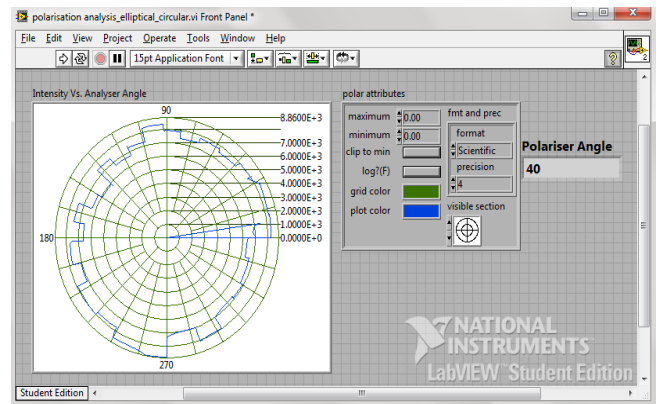

FIGURE 7(c). Intensity vs. θ variation for polarizer angle of 40° showing nearly circular polarization.

Earlier when the same experiment was done in the manual mode, students used to perform this experiment in nearly three hours as the number of observations to be taken and recorded were around 360. Afterwards, the whole analysis was to be done which was again a cumbersome time consuming process. Now after automation, they are able to complete the experiment along with the online analysis in just 30 minutes. The saved time can now be utilized for trying variations for better understanding of the experiment.

IV. CONCLUSION

The present development shows how a computer-assisted automation implemented through various sensors, data acquisition and graphical analysis tools can be used for understanding polarization concepts. The undergraduate students of Electronics have been able to measure various relevant parameters in the laboratory using this system and can understand their physical meaning. Taking advantage of the developed system, students have been able to avoid manual data collection and analysis, dedicating more time to observing the physical phenomenon, applying variations

and interpreting the results. Further work is in progress to characterize the polarizing elements using Jones' calculus.

ACKNOWLEDGEMENT

Authors, AG and VD, duly acknowledge University Grants Commission, New Delhi, India for providing the financial assistance under the major research proposal scheme for the work reported in this paper against sanction no. 34-62/2008(SR) for the project entitled "Investigating science hands-on to promote innovation and research at the undergraduate level".

REFERENCES

- [1] Garg, A., Sharma, R. and Dhingra V., *Computer Assisted Magnetism Studies*, Latin American Journal of Physics Education **4**, 523-520 (2010).
- [2] Garg, A., Sharma, R. and Dhingra V., *Automating Energy Band-Gap Measurements in Semiconductors Using LabVIEW*, European Journal of Physics Education **1**, 5-17 (2010).
- [3] Garg, A., Sharma, R. and Dhingra V., *An Inexpensive Hall Effect Set up*, Physics Education **26**, 297-310 (2009).
- [4] Kraftmakher, Y., *A differential magnetic circuit for teaching purposes*, Eur. J. Phys. **31**, 1239-1247 (2010).
- [5] Hsu, W. T. and Bahrim, C., *Accurate measurements of refractive indices for dielectrics in an undergraduate optics laboratory for science and engineering students*, Eur. J. Phys. **30**, 1325-1336 (2009).
- [6] Gan, K K. and Law, A T., *Measuring slit width and separation in a diffraction experiment*, Eur. J. Phys. **30**, 1271-1276 (2009).
- [7] Kraftmakher, Y., *Measurement of small optical polarization rotations*, Eur. J. Phys. **30**, 271-276 (2009).
- [8] Ouseph, P. J., Driver, K. and Conklin, K., *Polarization of light by reflection and the Brewster angle*, American Journal of Physics **69**, 1166-1168 (2001).
- [9] Severn, G. D. and Steffensen, T., *A simple extension of Richardt's method for measuring the ratio of specific heats of air using microcomputer-based laboratory sensors*, American Journal of Physics **69**, 387-389 (2001).
- [10] De Izarra, C. and Vallee, O., *On the use of linear CCD image sensors in optics experiments*, American Journal of Physics **62**, 357-361 (1994).
- [11] Wong, D., Lee, P. and Foong, S. K., *A datalogger demonstration of electromagnetic induction with a falling, oscillating and swinging magnet*, Phys. Educ. **45**, 394-401 (2010).
- [12] Ajith Kumar, B P, Satyanarayana, V. V. V., Singh, K., Singh, P., *Innovative science experiments using Phoenix*, Phys. Educ. **44**, 469-473 (2009).
- [13] Greaves, E. D. Rodriguez, A. M. and Camacho, A. J., *A one-way speed of light experiment*, American Journal of Physics **77**, 894-896 (2009).
- [14] Amrani, D., and Paradis, P., *Malus' law of light polarization using a Computer-Based Laboratory*, Lat. Am. J. Phys. Educ. **3**, 229-231 (2009).
- [15] <http://www.lunatechnologies.com/files/21intropolarizationweb.pdf>, visited on 27th May 2010.
- [16] <http://hyperphysics.phy-astr.gsu.edu/hbase/phyopt/polclas.html#c2>, visited on 04th May 2010.