



-Ing supplementary clauses and narrative discourse referents

M^a ÁNGELES MARTÍNEZ
Universidad Complutense de Madrid

Received: 1 February 2012 / Accepted: 27 April 2012

ABSTRACT

This study explores the connections between *-ing* supplementary clauses and narrative discourse foregrounding. Subordinate and, very particularly, non-finite clauses are prototypically associated to narrative background. Using a corpus of extracts from contemporary novels in English, this study, however, shows that this type of subordination displays a predominance of grammatically highlighting features, namely assertive modality, active transitivity processes, and the foregrounded focalizer as most frequent implicit subject. This fact may prove of relevance to both linguistics and literature, as it not only provides a discourse-based cognitive explanation for the apparent incorrectness of non-co-referential implicit subjects, as in “*Leaving the forest, the scent of the trees surrounded them*” (Biber et al., 2010: 829), but also suggests that *-ing* supplementives might intervene in narrative foregrounding, syntactically realizing some of the highlighting devices mentioned in cognitive approaches to the study of language at large (Brisard, 2002; Cristofaro, 2005; Kita, 2008; Talmy, 2000a; Talmy, 2000b), and literary discourse in particular (Tsur, 2009).

KEYWORDS:

Mental scenarios, foregrounding, narrative discourse, subordination, reference.

RESUMEN

Este estudio explora la relación entre las oraciones adverbiales de gerundio —*ing* supplementives—, y el primer plano perceptual en discurso narrativo. La subordinación sintáctica y, más en concreto, las oraciones subordinadas no personales, se asocian prototípicamente al fondo narrativo. El análisis de un corpus de extractos de narrativa de ficción contemporánea en lengua inglesa muestra, sin embargo, que en las oraciones suplementivas en *-ing* predominan elementos gramaticales relacionados con la prominencia, como son la modalidad asertiva, los procesos activos de transitividad, y la presencia del personaje focalizador como frecuente sujeto implícito. Esta relación puede ser relevante en estudios tanto lingüísticos como literarios, pues no solo proporciona una explicación cognitiva y discursiva para la aparente incorrección de los sujetos implícitos no-co-referenciales, como, por ejemplo, “*Leaving the forest, the scent of the trees surrounded them*” (Biber et al., 2010: 829), sino que también sugiere que las oraciones suplementivas en *-ing* podrían intervenir en la puesta de relieve en discurso narrativo, al dar realización gramatical a algunos de los mecanismos de prominencia lingüística que se mencionan en la investigación cognitiva del estudio del lenguaje en general (Brisard, 2002; Cristofaro, 2005; Kita, 2008; Talmy, 2000a; Talmy, 2000b), y del discurso literario en particular (Tsur, 2009).

PALABRAS CLAVE:

Representaciones mentales, primer plano perceptual, discurso narrativo, subordinación, referencia.

**Address for correspondence:* M^a Ángeles Martínez. Departamento de Filología Inglesa I (Lingüística Inglesa, Ciudad Universitaria s/n, 28040, Madrid, Spain. Tel: 00 34 913945441; E-mail: ma.martinez@filol.ucm.es

1. INTRODUCTION

Sentence grammar defines *-ing* supplementive clauses as a type of non-finite constructions functioning as circumstance adjuncts or adverbials (Biber *et al.*, 2010: 201, 820; Greenbaum & Quirk, 2007: 328; Huddleston & Pullum, 2007: 207-209). These “loosely integrated clauses, marked off by a comma in writing, are found in initial, medial, or final position” (Biber *et al.*, 2010: 201), as can be observed in the examples below:

1. *Deciding there was nothing to lose*, Clive cupped his hand about his mouth and leaned down to speak in Pullman’s ear. (MacEwan, 2005: 11)
2. A group of English tourists, *hurrying in out of the rain*, glanced back at him. (Pynchon, 1985: 99)
3. The tennis coach has moved to stand at the broad window, *feeling at the back of his crewcut*. (Wallace, 2009: 5)

Like many non-finite constructions, *-ing* supplementive clauses lack overt subject and tense indicators, sharing both subject and temporal reference with the superordinate clause (Biber *et al.*, 2010: 201, 782-783, 820-825, 829; Gelderen, 2002: 145; Greenbaum and Quirk, 1990: 327; Hengeveld, 1997: 82; Huddleston & Pullum, 2007: 207-209; Huston, 1985: 201-203; Carter and MacCarthy, 2006: 546). In fact, implicit *-ing* subjects are said to conform to the following matrix clause subject attachment rule: “When a subject is not present in a non-finite verbless clause, the normal ATTACHMENT RULE for identifying the subject is that it is assumed to be identical in reference to the subject of the superordinate clause” (Greenbaum and Quirk, 2007: 327).

But, side by side with co-referential *-ing* supplementives, it is possible to find cases in which the implicit subject differs from that in the matrix clause, as in the examples below. These non-co-referential occurrences are considered to be incorrect and deviant from a syntactic standpoint (Biber *et al.*, 2010: 829; Greenbaum and Quirk, 2007: 328; Huddleston and Pullum, 2007: 208):

4. *Leaving the road*, the deep resin-scented darkness of the trees surrounded *them*. (Biber *et al.*, 2010: 829)
5. *Driving to Chicago that night*, a sudden thought struck *me* [I was driving]. (Greenbaum and Quirk, 2007: 328)

The research hypothesis of this study is that non-co-referential cases may be perfectly understood when considered from a discourse perspective, and within a cognitive paradigm which sees reference not as pointing to a co-textual referent, but to a mental referent in the reader’s/listener’s mind (Duchan *et al.*, 1995; Emmott, 1997; Lambrou & Stockwell, 2007; Rong, 2011; Sidner, 1983). The analysis focuses on the frequency of co-occurrence, in *-ing* supplementive clauses, of certain foreground-connected grammatical features –implicit subject referent, transitivity processes, and assertive modality–, using a corpus of extracts

from contemporary novels in English. The results show that, despite the default association between narrative background and syntactic subordination (Cristofaro, 2005; Talmy, 2000a; Thompson, 1987; Tsur, 2009), *-ing* supplementives present a high frequency of correlation with highlighting grammar, a fact which could support the research hypothesis that, when implied subjects differ from those in the main clause, the referent is, nevertheless, easily recoverable by readers/listeners from their currently more strongly activated mental scenario. In this sense, *-ing* supplementives may be said to perform a character foregrounding function in narrative discourse.

2. NON-CO-REFERENTIAL SUBJECTS

-Ing supplementive clauses in which the implied subject does not coincide with the subject of the superordinate clause are known as *dangling participles* (Biber et al., 2010: 829; Huddleston and Pullum, 2007: 207). Academics' attitudes to non-co-referential *-ing* clauses range from utter intolerance to unveiled preoccupation, and the contextual scope used in these judgements on correctness is, invariably, intrasentential, maintaining that the violation of the matrix clause subject attachment rule "is considered to be an error. Such unattached (or dangling) clauses are totally unacceptable if the sentence provides no means for identifying the implied subject" (Greenbaum and Quirk, 2007: 328), or even that "The prescriptive rule is as follows: "The subject of a clause with a participle in it (i.e. without a subject of its own) must be the same as the subject of the main clause" (van Gelderen, 2002: 145). The subject attachment rule may, however, be relaxed in certain cases, which apply to all non-finite adverbial clauses (Biber et al., 2010: 829). The first of these cases are occurrences of the *-ing* clause as a style disjunct, with the *I* of the speaker as implied subject, as in example (6). The second involves prop *it* as implied subject, as in example (7):

6. *Putting it mildly*, you have caused us some inconvenience. (Greenbaum and Quirk, 2007: 328)

7. *Being Christmas*, the government offices were closed. ['Since it was...'] (Greenbaum and Quirk, 2007: 328)

Finally, subject co-referentiality may also be overridden in certain common expressions which imply speaker and listener collaboration, such as *Taking into account...*, *Turning to...*, *Considering...*, *Generally speaking...*, *Judging from...* (Huddleston & Pullum, 2007: 329; van Gelderen, 2002: 145), and which have become entrenched in language.

However, language users, even highly literate ones, annoyingly insist on producing non-co-referential *-ing* supplementives of all sorts, and have no problem in identify the implied referent, as in examples (4) and (5) above. These 'unacceptable' occurrences are supposedly banned by editors of high-quality publications (Biber *et al.*, 2010), but can be found even in

literary masterpieces like Shakespeare's *Hamlet* (Huddleston & Pullum, 2007: 209; van Gelderen, 2002: 145), where Hamlet's father's ghost says to his son:

8. "'Tis given out that, *sleeping in mine orchard*, a serpent stung *me*'".

Little could the great playwright have imagined, when he wrote these lines, that he was posing up a riddle for future generations of language specialists, confronted with the dilemma of disapproving of the grammatical correctness of the genius's sentence, or accepting the non-co-referentiality of the implied subject of *sleeping*. In fact, recent accounts of the issue of subject allocation in *-ing* supplementives occasionally adopt a more discourse-oriented attitude, and are not so critical of non-co-referential cases. Frequently, occurrence in everyday language use is simply acknowledged, on the assumption that that there must be some functional reason why language users have no difficulty in identifying non-co-referential implied subjects. In their 2007 *A Student's Introduction to English Grammar*, Huddleston & Pullum (2007: 208) seem to have dropped the issue of correctness/ incorrectness in favour of actual occurrence and user choice:

- to some speakers a non-subject NP in the matrix clause seems just as good as a basis for figuring out what the understood subject in the adjunct should be (though speakers don't often agree on which ones);
- many sentences are found in which no NP in the sentence gives any clue as to the understood subject, so it must be filled in by guesswork from the context (and speakers don't all agree about when that is acceptable, either).
- The main clue to the understood subject in this construction is often given by the matrix clause subject [...], but there is a wide range of other possibilities for interpretation of differing degrees of acceptability. (Huddleston & Pullum, 2007: 208)

In these attempts at explaining the processes at work in readers' minds when inferring non-co-referential implied subjects, the authors still seem to rely on previous or later mentions in the text, with a vague reference to "guesswork from the context". The cognitive approaches to reference in narrative discourse (Duchan et al., 1995; Emmott, 1997; Rong, 2011; Sidner, 1983) followed in this study, suggest that the explicit mention of a referent in surrounding context is not the key to implicit subject identification, as the referent is not in the text, nor in an exophoric context, but in the cooperatively built mental representation of the state of affairs in speakers' and hearer's minds. In fact, in all the non-co-referential examples presented -so far, including Shakespeare's, it can be observed that the implied subject in the non-finite clause is the entity currently in the foreground of the reader's perception, even if not occurring as syntactic subject of the matrix clause. For instance, the use of anaphoric pronoun *them* in example (4) indicates that it is not necessary to identify the referent, because both speaker and hearer know who is being talked about; in other words, because the referent is the current focus of attention. The same happens in example (5), where the foregrounded status of *me* in

the discourse is reinforced by deictic *that night* in the subordinate clause, which points to the collaborative construction of a shared mental scenario by speaker and hearer.

3. SUBORDINATION AND LINGUISTIC BACKGROUND

References to the connection between syntactic subordination and linguistic background may be traced back to the late 70s and 80s, when cognitive semanticists like Leonard Talmy (Talmy, 1978), Paul Hopper (Hopper and Thompson, 1980), or Sandra Thompson (1987) explored the linguistic expression of perceptual saliency in discourse using the Gestalt psychology terms *foreground* and *background* (Vernon, 1970). The underlying assumption is that linguistic organization mirrors the cognitive processes involved in visual perception, in the sense that the human mind tends to perceive certain entities as salient and others as part of the background, and that this process is wholly dependent on what our attention chooses –or is encouraged– to focus on. Perspectival stance is essential to understanding the way the human mind processes discourse, including narrative discourse, where certain entities and events are presented as focus of attention, while others are linguistically moved to the background. As with real world entities, no narrative event or character is intrinsically part of the foreground or the background. Rather, language users have at their disposal a variety of linguistic resources which function as highlighting devices directing readers'/listeners' attention towards certain characters and events in the fictional world (Brisard, 2002; Cristofaro, 2005; Gavins and Steen, 2003; Herman et al., 2008; Hopper, 1979; Kita, 2008; Lambrou and Stockwell, 2007; Semino and Culpeper, 2002; Stockwell, 2002; Talmy, 2000a: 315-316; Tsur, 2009; Ungerer and Schmid, 1996; Wallace, 1982: 212). Some of these are presented in Table 1.

+	MORE PROMINENT	LESS PROMINENT	--
	1. ENTITY		
	Human Animate Singular Countable	Non-human Inanimate Non-singular Uncountable	
	2. EVENT		
	Perfective aspect High transitivity Assertive modality Main clause	Imperfective aspect Low transitivity Non-assertive modality Subordinate clause	

Table 1. Language and perspectival prominence

In narrative fiction, the referent which is most frequently presented as focus of attention is the focalizer, or character through whose consciousness the fictional world is presented. As Hewitt (1995: 326) explains, “The subjective experiencer is always the most highly psychologically activated nominal, and is therefore the best candidate for anaphoric resolution”. Similarly, narrative events intended to be perceived as part of the salient main story line (MSL), or story skeleton, are presented using the simple past tense, assertive modality, and perfective aspect. In other words, they are presented as actually having taken place, in chronological sequence, at some definite time in the past. Backgrounded, supportive information, usually in the form of commentary, flashbacks, or evaluation, has no chronological sequence constraints, and shows an unmarked association with tenses other than the simple past, non-assertive modality, and imperfective aspect (Cristofaro, 2005; Hopper, 1979; Tsur, 2009). Different degrees of narrative prominence may be achieved through a combination of these linguistic features, ranging from the presence of human vs inanimate subjects or the use of active vs. passive transitivity processes, to the choice of embedding the event in a subordinate vs. a non-subordinate clause. In this sense, *-ing* supplementary clauses present events imperfectively, as incomplete and simultaneous with one or more events in the main story line, and thus display two clear linguistic features of narrative background: imperfective aspect and syntactic subordination. However, in most cases, their linguistic organization also involves a predominance of highlighting language, connected to reference, transitivity, and modality, as shown below.

4. METHODOLOGY

The corpus used in the analysis consists of five extracts from four novels and a short story in English, with a total of 50,680 words, distributed in the following way:

NOVEL	AUTHOR	PAGES	N. OF WORDS	FOCALIZER
<i>Justine</i>	Lawrence Durrell	17-47	14,926 words	first person
<i>Amsterdam</i>	Ian MacEwan	3-26	11,309 words	third person
<i>Infinite Jest</i>	David Foster Wallace	3-17	6,799 words	first person
<i>Travels in the Scriptorium</i>	Paul Auster	1-22	6,499 words	third person
“Under the Rose”	Thomas Pynchon	95-131	11,147 words	third person

Table 2. Sample texts

In all cases, the extract is the opening chapter or section in the novel, aiming at similar stages of referent presentation and topicality. The main criterion used in novel choice was to have a balanced presence of first and third person narration, as the most highly activated mental referent in fictional narrative is, invariably, the focalizer. As can be observed in Table

2, *Justine* and *Infinite Jest* (21,725 words) have a first person narrator, where narrator and focalizer conflate in the same fictional character (example 9), while “Under the Rose”, *Amsterdam*, and *Travels in the Scriptorium* (28,955 words) use third person internal focalization (Genette, 1980), in which the narrator adopts the perspectival viewpoint of one of the characters in the story, as in example (10). In these examples, pronominal anaphoric references to the mental representation of the focalizer appear in italics. Zero anaphoric references in which the mental representation of the focalizer is involved are in parentheses:

9. “The interview room's other personnel include: the University's Director of Composition, its varsity tennis coach, and Academy prorektor Mr. A. deLint. C.T. is beside *me*; the others sit, stand and stand, respectively, at the periphery of *my* focus. The tennis coach jingles pocket-change. There is something vaguely digestive about the room's odor”. (Wallace, 2009: 3)
10. “It wasn't *his* intention (he) to walk away at this point, for *he* wanted (he) to hear Pullman's reply, but just then two loud groups cut in from left and right, one to pay respects to George, the other to honour the poet, and in a swirl of repositioning *Clive* found *himself* (he) freed and (he) walking away”. (MacEwan, 2005: 11)

A total number of 359 *-ing* supplementary clauses were found in the data, and their analysis has focused on three linguistic features. Regarding entity saliency, the frequency of occurrence of the foregrounded focalizer as implied subject in both co-referential and non-co-referential cases was found out and compared to the frequency of subjects other than the focalizer. Regarding event saliency, and given the invariability of imperfective aspectuality and syntactic subordination, attention was paid to the variables active/passive transitivity processes and assertive/non-assertive modality, two of the most relevant linguistic systems involved in narrative saliency.

Feature co-occurrence (Biber, 1995) is the focus of attention of this study, and the identification of groupings of foregrounding linguistic features co-occurring in *-ing* supplementary clauses results from using a discourse approach to grammatical organization. The use of concordancers and word search computer tools was initially tried on the data, but the lists obtained were insufficient in terms of accurate identification of the discourse referent for the *-ing* implied subject, as pronominal and zero reference in narratives often has to be traced back for paragraphs and even pages, and requires access to a much larger co-text than that provided by the programme, not to mention the building up of a global mental scenario. Below are some of the KWICK entries generated using *MonoConc* for Windows on Ian MacEwan's *Amsterdam*:

1. ...that she sought medical advice, [[expecting]] reassurance. Instead, she was sent for...
2. ...now to where he stood outside the door, [[receiving]] commiseration from a group of mourners...
3. ...had narrowed his pleading, greedy eyes. [[Refusing]] to consign her to a home, he had cared...
4. He excused himself and stepped aside, [[leaving]] his friend to proceed alone. Clive
- ...

As can be observed, identification of the character construct functioning as a mental referent for the implied subject in these -ing clauses is impossible, and frequently continues to be so when adjacent four or five lines are accessed. Even if immediate access to the complete text was possible, it would be highly painful, in many cases, to accurately identify the implied referent in a backwards retrieval maneuver, because building character constructs in narrative discourse is, as Emmott explains in her notion of *character construction* (Emmott, 1992; 1999), a sequential, cumulative process: “As we read we collect information from the text about each character [...] We build an ‘image’ in our mind and with every subsequent mention of the individual we not only add to this MENTAL REPRESENTATION, but utilize it” (Emmott, 1992: 222).

In fact, corpus researchers with a concern for the analysis of units beyond the word (Biber *et al.*, 2007; Fitzpatrick, 2007), point out the difficulty involved in computerized discourse studies, which must often be complemented with detailed qualitative analyses (Biber *et al.*, 2007: 4). This is the case with the present research, in which it is necessary to identify: a) the character construct currently functioning as mental referent for the implied-*ing* subject, and b) the status of this character as focalizing consciousness for a particular part of the narrative. It could be said that mental referent retrieval is subject to the kind of difficulties noted by Sinclair (1991: 5) when, in his seminal *Corpus, Concordance, Collocation*, he acknowledges that “There are also instances which do not easily detach from their contexts, or which require a very extensive stretch of text to avoid distortion”. Having direct access to the complete text is, in this case, essential to the identification of a focalizing character as implied subject, as this requires familiarity with the novel as a whole. It is still possible to disambiguate transitivity processes and modality types using a smaller quantity of co-text, but, since complete access was necessary for effective implied subject disambiguation, the three features considered –implied subject, transitivity process, and modality type– have been handled manually.

The small size of the corpus, on the other hand, makes it advisable to use the findings with care. Although early definitions of what constitutes a corpus are ambiguous about size (Tognini-Bonelli, 1996: 53), there is common agreement that “a corpus should be as large as possible” (Sinclair, 1991: 18) for the sake of representativity and reliability, and current definitions, influenced by the development in computerized corpora and analysis tools, accordingly shift towards the view of corpora as large machine-readable collections of text samples, and subscribe “the widespread current practice of only using “corpus” to refer to a relatively large collection of naturally-occurring texts, which have been stored in machine-readable form” (Deignan, 2005). If this view is adhered, then the 50,000 word-long collection of texts in this study could be understood as a linguistic sample rather than a corpus, and invites further research using larger narrative corpora.

5. RESULTS

5.1. Focalizers as implied subjects

As predicted, the focalizer is the most frequent syntactic subject in the *-ing* supplementary clauses in the corpus, with an average of 39.37 % occurrences (Table 3). Examples (11) and (12) present the current focalizer as implied subject referent:

11. “My application’s not bought,’ *I* am telling them, *calling into the darkness of the red cave that opens out before closed eyes*”. (Wallace, 2009: 11)
12. “*He* therefore stands up from the bed and takes a first tentative step towards the other side of the room, *feeling a sudden rush of dizziness as he does so*”. (Auster, 2007: 8)

%	Justine	Infinite Jest	U.theRose	Amsterdam	Travels	Total
Focalizer	31.20% N=39	31.75% N=20	40.91% N=45	60.00% N=24	48.89% N=22	39.37% N=150
Character 1	24.80% N=31	12.70% N=8	16.36% N=18	7.50% N=3	28.89% N=13	19.16% N=73
Character 2	17.60% N=22	12.70 % N=8	7.27% N=8	5.00% N=2	0% N=0	10.50% N=40
Character 3	8.00% N=10	11.11% N=7	5.45% N=6	5.00% N=2	0% N=0	6.56% N=25
Others	13.60% N=17	31.75% N=20	16.36% N=18	15.00% N=6	0% N=0	16.01% N=61
Inanimate	4.80% N=6	3.17% N=2	13.64% N=15	7.50% N=3	13.33% N=6	8.40% N=32
Total	100% N=125	100% N=65	100% N=110	100% N=40	100% N=41	100% N=381

Table 3. *-Ing* supplementary clauses: implied subject referents. (Total number=381, higher than actual total 359 clauses, as, occasionally, some of the characters occur in combination with one another in subject position, in two- or three-entity sets)

It is also possible for other human entities to occur as implied *-ing* subject referents, but in no case as frequently as the focalizer. The next most frequent characters occurring as implied subjects are referred to as *Char. 1* (19.16 %), *Char. 2* (10.50), and *Char. 3* (6.563%). These are usually secondary characters with a strong bearing in the plot, as in example (13), or a myriad of minor characters (*Others*, 16.01%) which occur sporadically, as in example (14):

13. “*She* [Justine] passes below my window, *smiling as if at some private satisfaction, softly fanning her cheeks with the little red fan*”. (Durrell, 1968: 22)
14. “A *young Hispanic woman* holds her palm against her mouth, *looking*”. (Wallace, 2009: 13)

Finally, as expected, inanimate subject referents (8.40%) are far less frequent than human, animate ones (91.60%). Example (15) presents one of these rare cases:

15. “The train pulled out at five past eight, heading into the sun”. (Pynchon, 1985: 114)

The results can be graphically observed in Figures 1 and 2.

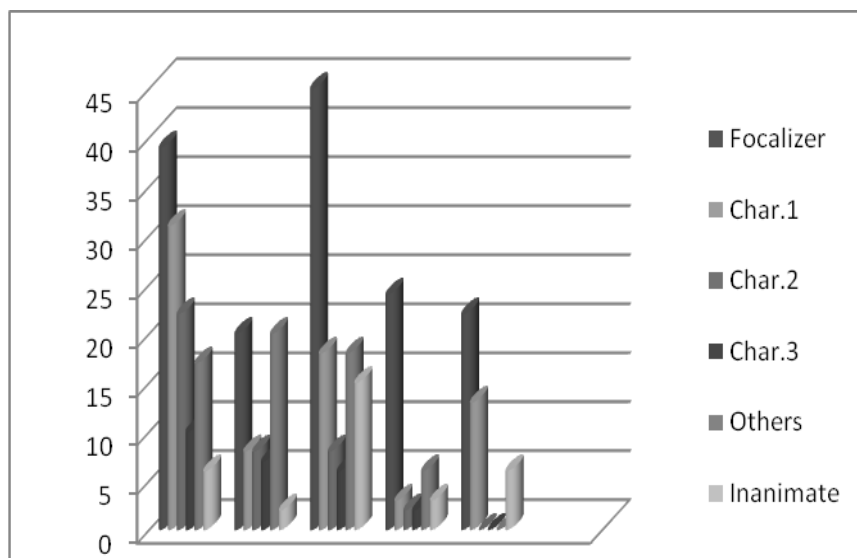

Figure 1. Implied *-ing* subject referents. Comparative results

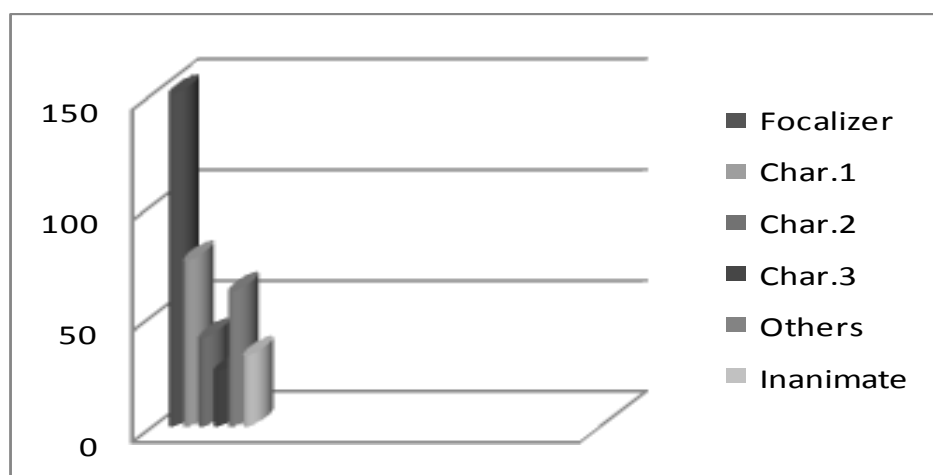

Figure 2. Implied *-ing* subject referents. Global results

As can be observed in the graphs, this part of the analysis seems to confirm the research hypothesis that *-ing* supplementary clauses tend to have the most highly activated referent, the focalizer, as implied subject. The second and third parts of the analysis will address the issue of event prominence in this subordinate clause type.

5.2. Transitivity processes

Two influential approaches to the linguistic encoding of semantic transitivity explicitly connect it to foregrounding. One is Halliday’s discussion of process types and related

participants, or case roles (Halliday, 1967; Halliday, 2000; Halliday & Matthiessen, 2004). The other is Hopper & Thompson's (1980) discussion of degrees of transitivity in terms of parameters such as agency and dynamism, or transference of effects onto an object. Studies of transitivity in literary discourse, in the sequel of M.A.K. Halliday's seminal analysis of *The Inheritors* (Halliday, 1971), are not infrequent (Martínez, 2002; Montgomery, 1993; Shen, 2007). The main assumption behind these studies is that the transitivity configuration of the clause makes significant meaning contributions to the mental representations being constructed in readers'/listeners' minds, including indicators as to which participants and processes are linguistically encouraged to be perceived as salient. Active processes, particularly MATERIAL, MENTAL, and BEHAVIOURAL ones, and, to a lesser extent, VERBAL, are more frequently connected to narrative foreground, while passive processes, particularly RELATIONAL and EXISTENTIAL, contribute to presenting events and entities as part of the background.

%	Justine	Infinite Jest	U.theRose	Amsterdam	Travels	Total
MATERIAL	41.82% N=46	39.68% N=25	52.48% N=53	50.00% N=20	37.78% N=17	44.85% N=161
BEHAV.	25.45% N=28	42.86% N=27	16.83% N=17	15.00% N=6	13.33% N=6	23.40% N=84
MENTAL	15.45% N=17	7.94% N=5	714.85% N=15	27.5% N=11	31.11% N=14	17.27% N=62
VERBAL	10% N=11	4.76% N=3	6.93% N=7	2.50% N=1	4.44% N=2	6.68% N=24
RELAT.	7.27% N=8	4.76% N=3	7.92% N=8	5.00% N=2	13.33% N=6	7.52% N=27
EXISTENT.	0% N=0	0% N=0	0.99% N=1	0% N=0	0% N=0	0.28% N=1
Total	100% N=110	100% N=63	100% N=101	100% N=40	100% N=45	100% N=359

Table 4. -Ing supplementary clauses: comparative table of transitivity processes

In this respect, the analysis of the *-ing* supplementary clauses in the corpus shows that the transitivity processes most frequently expressed by the *-ing* forms of the verb are MATERIAL (44.85%), BEHAVIOURAL (23.40%), and MENTAL (17.27%). VERBAL (6.68%), RELATIONAL (7.52%), and EXISTENTIAL (0.28%) processes are notably less frequent (Figure 3). Consider the examples below. Notice that the existential process in (20) is intrinsically non-co-referential, because it has its own existent subject. Therefore, *-ing* supplementary clauses containing an EXISTENTIAL process should probably be best considered cases of closed predication (Greenbaum & Quirk, 2007: 327; Hengeveld, 1997: 82):

16. "For long periods in the winter he is away on leave and *I* have a little dank flat to myself and sit up late, *correcting exercise books*, [...]". (Durrell, 1968: 24) [MATERIAL]

17. “As Mr. Blank shuffles into the white, windowless room with the black-and-white floor, Anna shuts the door behind him, and for several moments *Mr. Blank* just stands there, *looking at the toilet against the far wall* [BEHAVIOURAL], *suddenly feeling bereft* [MENTAL], *aching to be with Anna again*”. (Auster, 2007: 17) [MENTAL].
18. “[...] while *C.T.* in the reception area paces in a tight ellipse, *speaking into his portable phone.*” (Wallace, 2009: 9) [VERBAL]
19. “As for money, *being so inordinately rich, he* [Nessim] was possessed by a positive distaste for it, [...]”.(Durrell, 1968: 28) [RELATIONAL]
20. “*There being a temporary hitch in finances, only one could afford the usual accommodations*”. (Pynchon, 1985: 98) [EXISTENTIAL]

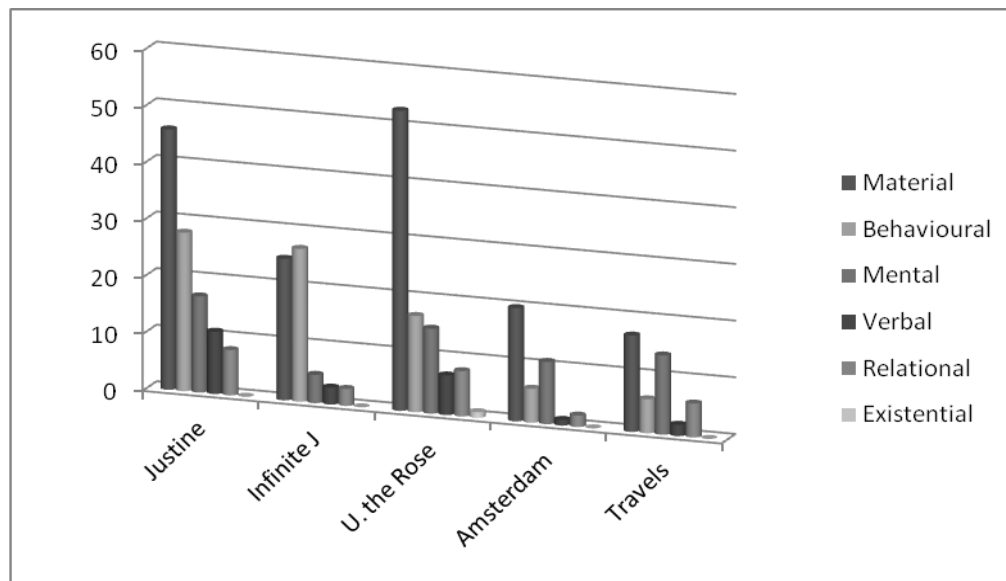

Figure 3. Transitivity processes. Comparative results

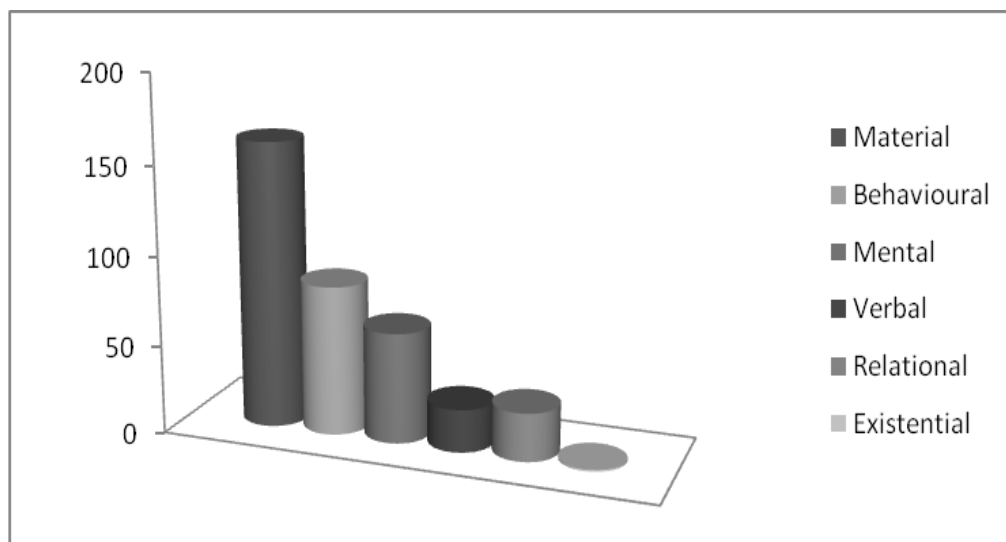

Figure 4. Transitivity processes. Global results

The predominance of MATERIAL, BEHAVIOURAL, and MENTAL processes in the *-ing* supplementary clauses in the corpus seems to confirm the research hypothesis that most implied subjects are presented as active semantic participants, particularly as ACTOR, BEHAVER, and SENSER, in the events in the fictional world, a fact which further supports

the research hypothesis that this type of subordinate clauses may be connected to character foregrounding. Figure 4 shows the global results.

5.3. Assertive modality

The research hypothesis is also confirmed in the third part of the analysis, dealing with speech act modality –assertion– and its association with linguistic prominence. As a speech act, an assertion conveys the speaker’s aim to present an event or situation as actual, independently of its real world status (Austin, 1975; Bybee et al., 1994; Cristofaro, 2005; Lambrecht, 1994; Langacker, 1991; Levinson, 1983; Nordström, 2010; Palmer, 2003). In this respect, assertive/non-assertive modality choices orient language users as to what can be assumed to be incorporated as actual into the cooperatively built mental representation of the state of affairs. In narrative discourse, the underlying assumption is that those events and situations linguistically presented as actually taking or having taken place are more likely to be incorporated into the salient main story line than those presented as possibilities, opinions, or unrealized wishes (Cristofaro, 2005; Hopper, 1979; Tsur, 2009).

As shown in Table 5 and Figures 5 and 6, the analysis shows that 83.84% of the *-ing* supplementary clauses found in the corpus are expressed using assertive modality, while 16.16% display the non-assertive choice. Consider the examples below. (21) is a case of assertivity, frequent in the corpus. (22), (23), and (24) exemplify some of the non-assertive possibilities found:

21. “Then to reassure himself, he repeats the same sentence, *shouting at the top of his lungs*”. (Auster, 2007: 8) [ASSERTIVE]
22. “[...]; the sister, Mildred, was in Egypt, she soon informed Porpentine, to gather rock specimens, *being daft for rocks in the same way Sir Alastair was for large and ancient pipe organs*”. (Pynchon, 1985: 104) [NON-ASSERTIVE: HEARSAY EVIDENTIAL]
23. “I turn this way and that, *sort of directing the expression to everyone in the room*”. (Wallace, 2009: 5) [NON-ASSERTIVE: EPISTEMIC INDETERMINACY]
24. “*Not knowing that other means of propulsion are available to him besides his legs*, Mr. Blank therefore stays where he is”. (Auster, 2007: 12) [NON-ASSERTIVE: NEGATIVE]

%	Justine	Infinite Jest	U.theRose	Amsterdam	Travels	Total
ASSERTIVE	94.55% N=104	49.21% N=31	87.13% N=88	97.50% N=39	86.67% N=39	83.84% N=301
NON-ASSERTIVE	5.45% N=6	50.79% N=32	12.87% N=13	2.5% N=1	13.33% N=6	16.16% N=58
Total	100% N=110	100% N=63	100% N=101	100% N=40	100% N=45	100% N=359

Table 5. *-Ing* supplementary clauses: modality comparative

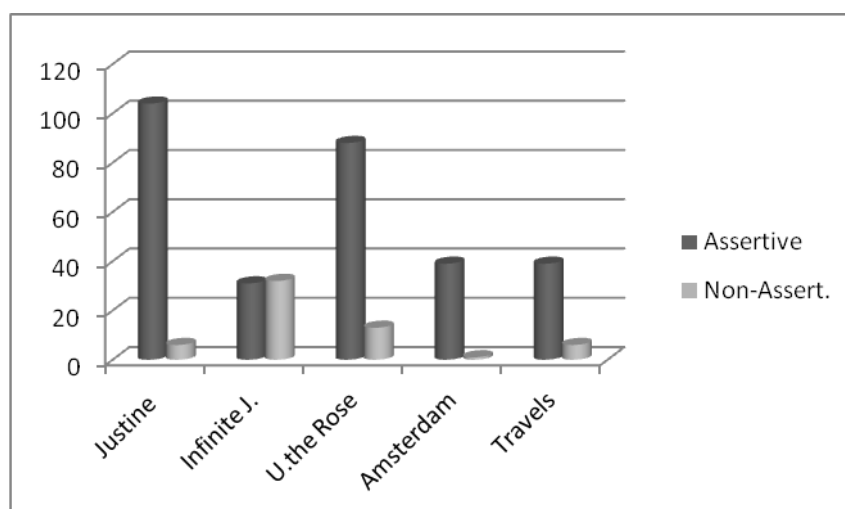

Figure 5. Modality comparative graph

As can be observed in Figure 5, assertive modality is, quite consistently, the preferred expression of events and situations in the *-ing* supplementives in the data, but its distribution is not wholly homogeneous across the corpus, as one of the extracts –the opening section of David Foster Wallace’s *Infinite Jest*– presents a similar presence of assertive and non-assertive predicates (49.21% assertive vs. 50.79% non-assertive). This may be explained by the fact that, in this extract, there is a lengthy sub-episode narrated in the form of recollection by one of the characters, Hal’s brother Orin, who recalls an incident from Hal’s childhood. This episode is not asserted, as it is presented as part of a character’s memories. It may thus be assumed that *-ing* supplementive clauses show a default association with assertive modality when the events or situations they depict are presented as simultaneous with narrative reference time, other cases deserving further exploration.

In fact, the global results (Figure 6) show a clear tendency for *-ing* supplementives to co-occur with assertive modality, consequently reinforcing the research hypothesis that this type of subordination intervenes in narrative foregrounding.

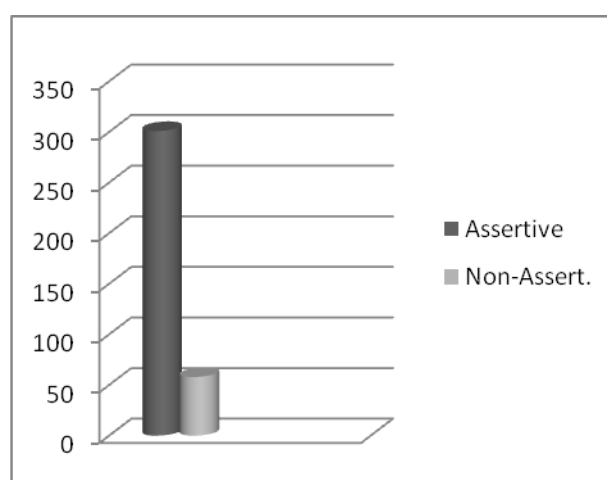

Figure 6. Modality: global results

6. DISCUSSION

This study has analyzed the frequency of co-occurrence, in *-ing* supplementive clauses, of three significant features, all of them linguistic expressions of discourse prominence: the focalizer as implied subject, material transitivity processes, and assertive modality. The results provide empirical evidence as to whether the violation of the matrix clause attachment rule for implied subjects in these non-finite clauses may be explained in connection to the effect of cognitive discourse salience, which overrides intrasentential syntactic constraints. Although limited by corpus size, the analysis indicates that, as predicted, subject co-referentiality with the superordinate clause is probably a side-effect of co-referentiality with the most prominent discourse entity in the linguistically prompted mental representation of the state of affairs. This confirms the research hypothesis that, in non-co-referential cases, the implied subject is easily recoverable by readers/listeners as the most prominent discourse entity in their currently activated mental scenario.

The corpus contains four non-co-referential *-ing* supplementive clauses in which the implied subject is different from the subject of the superordinate clause. They are reproduced below:

25. “Last week in Brindisi *their* compassion had been relentless as always; it gave *them* a certain moral advantage, [they] *realizing as they did that Porpentine was somehow incapable of returning it*”. (Pynchon, 1985: 96)
26. “So at some point, [he] *prowl[ing] any mews or alley in mid-century London*, the supreme rightness of “the game for its own sake” must have occurred to *him*, and acted as an irresistible factor aimed toward 1900”. (Pynchon, 1985: 107)
27. ““God! Help! My son ate this! Help!” she kept yelling, running a tight pattern just inside the square of string; and my brother Orin remembers noting how even in hysterical trauma *her* flight-lines were plumb, *her* footprints Native-American straight, *her* turns, inside the ideogram of string, crisp and martial, [she] *crying ‘My son ate this! Help!’* and [she] *lapping me twice before the memory recedes*”. (Wallace, 2009: 11)
28. “My head is cradled in a knelt Director’s lap, which is soft, *my* face being swabbed with dusty-brown institutional paper towels he received from some hand out of the crowd overhead, [I] *staring with all the blankness I can summon into his jowls’ small pocks, worst at the blurred jaw-line, of scarring from long-ago acne*”. (Wallace, 2009: 13)

In these examples it can be observed that, although in all cases the implied subject is not co-referential with the matrix clause subject, there is co-referentiality with matrix clause pronominal or possessive anaphoric reference to a prominent discourse participant, easily recoverable from the currently activated mental scenario. It should be recalled that pronominal and zero anaphoric reference indicates that the referent is a salient entity in the short-term mental representation of the fictional world. It could thus be concluded that subject identification in examples (25)-(28) above occurs by resorting to the most prominent discourse referent. The same could be said in examples (4) and (5) in the introduction,

“*Leaving the road, the deep resin-scented darkness of the trees surrounded them*” and “*Driving to Chicago that night, a sudden thought struck me*”, as well as in Shakespeare’s “*Sleeping in mine orchard, a serpent stung me*” (example 6). In all of them, as in the non-co-referential occurrences in the corpus, the matrix clause contains pronominal anaphoric reference implying a foregrounded, easily recoverable discourse referent as implied subject.

In this line, it could be claimed that readers/listeners have no difficulty in identifying non-co-referential subjects in *-ing* supplementive clauses because cognitive discourse prominence may override intrasentential syntactic constraints. Similarly, a possible functional motivation for the choice of a non-co-referential clause by language users may arise from a conflict between syntactic rule and discourse need for clarity or economy, allowing for a shortcut to mental reference. This is probably the case in examples (27) and (28) above, in which the first person narrator/focalizer, Hal Incandenza, is an extremely intelligent autistic young man whose swift thinking processes are represented using the narrative technique of free indirect thought; that is, they are linguistically presented as they probably occurred in the character’s mind. So, maybe, although non-co-referential *-ing* supplementives may occasionally be considered inaccurate or unpolished from a style point of view, this might very well be a genre-associated feature, as language users could knowingly choose non-co-referentiality to better fulfill a contextually appropriate, cognitively determined, communicative purpose.

7. CONCLUSION

The findings in this study provide evidence to support the research hypothesis that the implied subjects of *-ing* supplementive clauses can be best defined as co-referential with the most cognitively salient, and thus most easily recoverable, discourse entity in the currently activated mental scenario, rather than with the matrix clause syntactic subject. This cognitive-functional explanation is encouraged by the correlation of this type of non-finite clauses with certain highlighting linguistic features, namely, the most salient human participant as implied subject, MATERIAL transitivity processes, and assertive modality.

These findings have significant implications. In narrative fiction, the most prominent participant is the focalizer, or character from whose perspective the fictional world is presented. The fact that the focalizer is the most frequent referent for implied *-ing* supplementive subjects, and that these clauses tend to display active transitivity and assertive modality, indicates that this type of subordination may have a role to play in character foregrounding. In the second place, the confirmation of the saliency hypothesis suggests that the reason why language users recurrently produce and process non-co-referential *-ing* supplementives, in which the implied subject differs from the subject of the superordinate clause, is that the cognitive weight of the most prominent discourse referent overrides

intrasentential syntactic constraints for the sake of referential continuity and recoverability. This, in turn, may suggest that non-co-referential linguistic choices in these clauses may fulfill a communicative purpose, and, rather than erroneous or unacceptable, they could be, simply, more likely to be found in certain genres or discourse types. In this respect, further research would be needed to, on one hand, investigate *-ing* supplementive clauses in a larger narrative corpus, and, on the other, explore how they behave in genres other than fictional narrative. The analysis also shows that corpus analysis may throw light on language phenomena which can be better understood when considered from a discourse perspective, but it additionally highlights some of the difficulties frequently encountered in corpus discourse analysis, namely, the need for extensive access to context and co-text.

REFERENCES

- Auster, P. (2007). *Travels in the Scriptorium*. London: Faber and Faber.
- Austin, P. (1975). *How To Do Things With Words*. Oxford: Oxford University Press.
- Biber, D. (1995). *Dimensions of Register Variation. A Cross-Linguistic Comparison*. Cambridge: Cambridge University Press.
- Biber, D., Connor, U. & Upton, T. A. (2007). *Discourse on the Move: Using Corpus Analysis to Describe Corpus Structure*. Amsterdam: John Benjamins.
- Biber, D., Johansson, S., Leech, G., Conrad, S. & Finegan, E. (2010). *Grammar of Spoken and Written English*. London: Longman.
- Brisard, F. (2002). *Grounding: The Epistemic Footing of Deixis and Reference*. Berlin: Mouton de Gruyter.
- Brône, G. & Vandaele, J. (2009). *Cognitive Poetics: Goals, Gains and Gaps*. Berlin: Mouton de Gruyter.
- Bybee, J. L., Perkins, R. & Pagliuca, W. (1994). *The Evolution of Grammar: Tense, Aspect and Modality in the Languages of the World*. Chicago: The University of Chicago Press.
- Carter, R. & McCarthy, M. (2006). *Cambridge Grammar of English*. Cambridge: Cambridge University Press.
- Cristofaro, S. (2005). *Subordination*. Oxford: Oxford University Press.
- Deignan, A. (2005). *Metaphor and Corpus Linguistics*. Amsterdam, Philadelphia: John Benjamins.
- Duchan, J. F., Bruder, G. A. & Hewitt, L. E. (1995). *Deixis in Narrative: a Cognitive Science Perspective*. Hillsdale, NJ: Lawrence Earlbaum.
- Durrell, L. (1968). *The Alexandria Quartet*. London: Faber and Faber.
- Emmott, C. (1992). Splitting the referent: an introduction to narrative enactors. In M. Davies & L. Ravelli (Eds.), *Advances in Systemic Linguistics: Recent Theory and Practice* (pp. 221-228). London: Pinter.
- Emmott, C. (1999). *Narrative Comprehension: A Discourse Perspective*. Oxford: Oxford University Press.
- Fitzpatrick, E. (2007). *Corpus Linguistics Beyond the Word: Corpus Research from Phrase to Discourse*. Amsterdam: Rodopi.
- Gavins, J. & Steen, G. (2003). *Cognitive Poetics in Practice*. Oxon: Routledge.
- Geeraerts, D. & Cuyckens, H. (2007). *The Oxford Handbook of Cognitive Linguistics*. New York: Oxford University Press.
- Genette, G. (1980). *Narrative Discourse. An Essay in Method*. Ithaca: Cornell University Press.
- Greenbaum, S. & Quirk, R. (2007). *A Student's Grammar of the English Language*. London: Longman.

- Halliday, M. A. K. (1967). Notes on transitivity and theme in English. Parts 1, 2, and 3. *Journal of Linguistics* 3.1, 3.2, & 4.2 1967/68, 37-81/199-244 and 179-215.
- Halliday, M. A. K. (1971). Linguistic function and literary style: an inquiry into the language of William Golding's *The Inheritors*. In S. Chatman (Ed.), *Literary Style: A Symposium* (pp. 330-368). Oxford: Oxford University Press.
- Halliday, M. A. K. (2000). *An Introduction to Functional Grammar*. London: Edward Arnold.
- Halliday, M. A. K. & Matthiessen, C. (2004). *An Introduction to Functional Grammar*. London: Hodder-Arnold.
- Hengeveld, K. (1997). *The Theory of Functional Grammar. Part 2. Complex and Derived Constructions*. Berlin, New York: Mouton de Gruyter.
- Herman, D., Jahn, M. & Ryan, M. (Eds.). (2008). *Routledge Encyclopedia of Narrative Theory*. New York: Routledge.
- Hewitt, L. E. (1995). Anaphor in subjective contexts in narrative fiction. In J. F. Duchan, G. Bruder & L. E. Hewitt (Eds.), *Deixis in Narrative. A Cognitive Science Perspective* (pp. 325-339). Hillsdale, NY: Lawrence and Earlbaum.
- Hopper, P. J. (1979). Aspect and foregrounding in discourse. In T. Givón (Ed.), *Syntax and Semantics, Vol.12. Discourse and Syntax* (pp. 213-241). London: Academic Press.
- Hopper, P. J. & Thompson, S. (1980). Transitivity in grammar and discourse. *Language*, 56(2), 251-299.
- Huddleston, R. & Pullum, G. (2007). *A Student's Introduction to English Grammar*. Cambridge: Cambridge University Press.
- Huston, A. C. (1985). *Continuity and Change in English Morphology: the Variable (ING)*. Cambridge: Cambridge University Press.
- Kita, S. (2008). Figure-Ground indeterminacy in descriptions of spatial relations: A construction grammar account. In M. Bowerman & P. Brown (Eds.), *Crosslinguistic Perspectives on Argument Structure*. (pp. 89-109). London: Lawrence Earlbaum.
- Lambrecht, K. (1994). *Information Structure and Sentence Form: Topic, Focus, and the Mental Representation of Discourse Referents*. Cambridge: Cambridge University Press.
- Lambrou, M. & Stockwell, P. (2007). *Contemporary Stylistics*. London, NY: Continuum.
- Langacker, R. W. (1991). *Foundations of Cognitive Grammar. Vol. II. Descriptive Application*. Stanford: Stanford University Press.
- Levinson, S. C. (1983). *Pragmatics*. Cambridge: Cambridge University Press.
- MacEwan, I. (2005). *Amsterdam*. London: Vintage.
- Martínez, M. A. (2002). From "Under the Rose" to "V": A linguistic approach to human agency in Pynchon's fiction. *Poetics Today*, 23(4), 633-656.
- Montgomery, M. (1993). Language, character, and action: A linguistic approach to the analysis of character in a Hemingway short story. In J.M. Sinclair, M. Hoey & G. Fox (Eds.), *Spoken and Written Discourse* (pp. 127-142). London: Routledge.
- Nordström, J. (2010). *Modality and Subordinators*. Amsterdam, Phil.: John Benjamins.
- Palmer, F. R. (2003). *Mood and Modality*. Cambridge: Cambridge University Press.
- Pynchon, T. (1985). Under the Rose. In T. Pynchon, *Slow Learner*. (pp. 95-131). London: Pan Books.
- Rong, R. (2011). Contextual frame theory and monitoring flashbacks. *Online Proceedings of the Annual Conference of the Poetics and Linguistics Association (PALA)*. Retrieved from www.pala.ac.uk/resources/proceedings/2011/rong2011/pdf
- Semino, E. & Culpeper, J. (2002). *Cognitive Stylistics: Language and Cognition in Text Analysis*. Amsterdam, Phil.: John Benjamins.
- Shen, D. (2007). Internal contrast and double decoding: transitivity in Hughes's "On the Road". *Journal of Literary Semantics*, 36, 53-70.
- Sidner, C. L. (1983). Focusing in the comprehension of definite anaphora. In M. Brady & R. C. Berwick (Eds.), *Computational Models of Discourse* (pp. 267-328). Cambridge, Mass.: MIT Press.
- Sinclair, J. (1991). *Corpus, Concordance, Collocation*. Oxford: Oxford University Press.
- Stockwell, P. (2002). *Cognitive Poetics. An Introduction*. London: Routledge.

- Talmy, L. (1978). Figure and Ground in complex sentences. In J.H. Greenberg (Ed.), *Universals of Human language. Vol. 4. Syntax.* (pp. 625-649). Stanford: Stanford University Press.
- Talmy, L. (2000a). *Toward a Cognitive Semantics Vol. I: Concept and Structuring Systems.* Cambridge, Mass.: MIT Press.
- Talmy, L. (2000b). *Toward a Cognitive Semantics Vol.II: Typology and Process in Concept Structuring.* Cambridge, Mass.: MIT Press.
- Thompson, S. A. (1987). "Subordination" and narrative event structure. In R. S. Tomlin (Ed.), *Coherence and Grounding in Discourse.* (pp. 435-454). Amsterdam, Philadelphia: John Benjamins.
- Tognini-Bonelli, E. (1996). *Corpus Linguistics at Work.* Amsterdam, Philadelphia: John Benjamins.
- Tsur, R. (2009). Metaphor and figure-ground relationship: comparisons for poetry, music, and the arts. In G. Brône & J. Vandaele (Eds.), *Cognitive Poetics: Goals, Gains, and Gaps.* Berlin. Mouton de Gruyter.
- Ungerer, F. & Schmid, H. (1996). *An Introduction to Cognitive Linguistics.* London and New York: Longman.
- van Gelderen, E. (2002). *An Introduction to the Grammar of English.* Amsterdam, Phil.: John Benjamins.
- Vernon, M. D. (1970). *The Psychology of Perception.* Harmondsworth: Penguin.
- Wallace, D. F. (2009). *Infinite Jest.* London: Abacus.
- Wallace, S. (1982). Figure and Ground: the interrelationship of linguistic categories. In P. J. Hopper (Ed.), *Tense-Aspect: Between Semantics and Pragmatics* (pp. 201-223). Amsterdam, Phil.: John Benjamins.

