

Research Articles // Artículos de investigación

- Juan Carmelo Visdómine Lozano 257-271 Brain Activation for Effort in Human Learning: A Critical and Systematic Review of fMRI Studies.
- Daniela M Salazar
Francisco J Ruiz
Cindy L Flórez
Juan C Suárez Falcón 273-287 Psychometric Properties of the Generalized Pliance Questionnaire -Children.
- Ciara Dunne
Ciara McEnteggart
Colin Harte
Dermot Barnes-Holmes
Yvonne Barnes-Holmes 289-300 Faking a Race IRAP Effect in the Context of Single versus Multiple Label Stimuli.
- Hortensia Hickman Rodríguez
M Luisa Cepeda Islas
Diana Moreno Rodríguez
Sergio M Méndez
Rosalinda Arroyo Hernández 301-313 Tipos instruccionales y regulación verbal. Comparación entre niños y adultos. [*Types of instructions and verbal regulation. Comparative study between children and adults.*]
- Valeria E Morán
Fabián O Olaz
Edgardo R Pérez
Zilda AP Del Prette 315-330 Emotional-Evolutional Model of Social Anxiety in University Students.
- Louis De Page
Paul T van der Heijden
Mercedes De Weerd
Jos IM Egger
Gina Rossi 331-343 Differentiation between Defensive Personality Functioning and Psychopathology as Measured by the DSQ-42 and MMPI-2-RF.
- Julieta Azevedo
Paula Castilho
Lara Palmeira 345-356 Early Emotional Memories and Borderline Symptoms: The Mediating Role of Decentering.
- Angel Javier Tabullo
Violeta Araceli Navas Jiménez
Claudia Silvana García 357-370 Associations between Fiction Reading, Trait Empathy and Theory of Mind Ability.
- Lorraine T Benuto
Jonathan Singer
Jena Casas
Frances González
Allison Ruork 371-384 The Evolving Definition of Cultural Competency: A Mixed Methods Study.

Notes and Editorial Information // Avisos e información editorial

- Editorial Office 387-388 Normas de publicación-*Instructions to authors*. Cobertura e indexación de IJP&PT. [*IJP&PT Abstracting and Indexing.*]
- Editorial Office 389

IJP&PT

INTERNATIONAL JOURNAL OF PSYCHOLOGY & PSYCHOLOGICAL THERAPY

EDITORFrancisco Javier Molina Cobos
Universidad de Almería, España**REVIEWING EDITORS**Mónica Hernández López
Universidad de Jaén
EspañaFrancisco Ruiz Jiménez
Fundación Universitaria Konrad Lorenz
Colombia**ASSOCIATE EDITORS**Dermot Barnes-Holmes
Universiteit Gent
BelgiumJ. Francisco Morales
UNED-Madrid
EspañaMauricio Papini
Christian Texas University
USAMiguel Ángel Vallejo Pareja
UNED-Madrid
EspañaKelly Wilson
University of Mississippi
USA**ASSISTANT EDITORS**Adolfo J. Cangas Díaz
Emilio Moreno San PedroUniversidad de Almería, España
Universidad de Huelva, España**MANAGING EDITOR**Adrián Barbero Rubio
Universidad de Almería & MICPSY, EspañaEDITORIAL OFFICE/SECRETARÍA DE EDICIÓN
MICPSY
Madrid, España

IJP&PT

INTERNATIONAL JOURNAL OF PSYCHOLOGY & PSYCHOLOGICAL THERAPY

Editor: Francisco Javier Molina Cobos, *Universidad de Almería, España*

Associate Editors

Dermot Barnes-Holmes, *Universiteit Gent, Belgique-België*
Francisco Morales, *UNED, Madrid, España*
Mauricio Papini, *Christian Texas University, USA*
Miguel Ángel Vallejo Paraja, *UNED, Madrid, España*
Kelly Wilson, *University of Mississippi, USA*

Reviewing Editors

Mónica Hernández López, *Universidad de Jaén, España*
Francisco Ruiz Jiménez, *Fundación Universitaria Konrad Lorenz, Colombia*

Assistant Editors

Adolfo J. Cangas Díaz, *Universidad de Almería, España*
Emilio Moreno San Pedro, *Universidad de Huelva, España*

Managing Editor

Adrián Barbero Rubio *Universidad de Almería & MICPSY, España*

Consejo Editorial/Editorial Board

Yolanda Alonso *Universidad de Almería, España*
Erik Arntzen *University of Oslo, Norway*
M^a José Bágüena Puigcerver *Universidad de Valencia, España*
Yvonne Barnes-Holmes *National University-Maynooth, Ireland*
William M. Baum *University of New Hampshire, USA*
Gualberto Buela Casal *Universidad de Granada, España*
Francisco Cabello Luque *Universidad de Murcia, España*
José Carlos Caracuel Tubío *Universidad de Sevilla, España*
Gonzalo de la Casa *Universidad de Sevilla, España*
Charles Catania *University of Maryland Baltimore County, USA*
Juan Antonio Cruzado *Universidad Complutense, España*
Victoria Díez Chamizo *Universidad de Barcelona, España*
Michael Dougher *University of New Mexico, USA*
M^a Paula Fernández García *Universidad de Oviedo, España*
Perry N Fuchs *University of Texas at Arlington, USA*
Andrés García García *Universidad de Sevilla, España*
José Jesús Gázquez Linares *Universidad de Almería, España*
Inmaculada Gómez Becerra *Universidad de Almería, España*
Luis Gómez Jacinto *Universidad de Málaga, España*
M Victoria Gordillo Álvarez-Valdés *Universidad Complutense, España*
Celso Goyos *Universidade de Sao Paulo, Brasil*
David E. Greenway *University of Southwestern Louisiana, USA*
Patricia Sue Grigson *Pennsylvania State College of Medicine, USA*
Steven C. Hayes *University of Nevada-Reno, USA*
Linda Hayes *University of Nevada-Reno, USA*
Phillip Heline Temple *University, USA*
Per Holth *University of Oslo, Norway*
Robert J. Kohlenberg *University of Washington, Seattle, USA*
María Helena Leite Hunzinger *Universidade de Sao Paulo, Brasil*
Julian C. Leslie *University of Ulster at Jordanstown, UK*
Juan Carlos López García *Universidad de Sevilla, España*
Fergus Lowe *University of Wales, Bangor, UK*
Armando Machado *Universidade do Miño, Portugal*
G. Alan Marlatt *University of Washington, Seattle, USA*
Jose Marques *Universidade do Porto, Portugal*
Helena Matute *Universidad de Deusto, España*
Ralph R. Miller *State University of New York-Binghamton, USA*
Fernando Molero *UNED, Madrid, España*
Rafael Moreno *Universidad de Sevilla, España*
Ignacio Morgado Bernal *Universidad Autónoma Barcelona, España*
Edward K. Morris *University of Kansas-Lawrence, USA*
Lourdes Munduate *Universidad de Sevilla, España*
Alba Elisabeth Mustaca *Universidad de Buenos Aires, Argentina*
José I. Navarro Guzmán *Universidad de Cádiz, España*
Jordi Obiols *Universidad Autónoma de Barcelona, España*
Sergio M. Pellis *University of Lethbridge, Canada*
Ricardo Pellón *UNED, Madrid, España*
Wenceslao Peñate Castro *Universidad de La Laguna, España*
Víctor Peralta Martín *Hospital V. del Camino, Pamplona, España*
M. Carmen Pérez Fuentes *Universidad de Almería, España*
Marino Pérez Álvarez *Universidad de Oviedo, España*
Juan Preciado *City University of New York, USA*
Emilio Ribes Iniesta *Universidad Veracruzana, México*
Josep Roca i Balasch *INEF de Barcelona, España*
Armando Rodríguez *Universidad de La Laguna, España*
Jesús Rosales Ruiz *University of North Texas, USA*
Juan Manuel Rosas Santos *Universidad de Jaén, España*
Kurt Saltzinger *Hofstra University, USA*
Mark R. Serper *Hofstra University, USA*
Arthur W. Staats *University of Hawaii, USA*
Carmen Torres *Universidad de Jaén, España*
Peter J. Urciuoli *Purdue University, USA*
Guillermo Vallejo Seco *Universidad de Oviedo, España*
Julio Varela Barraza *Universidad de Guadalajara, México*
Juan Pedro Vargas Romero *Universidad de Sevilla, España*
Graham F. Wagstaff *University of Liverpool*
Stephen Worchel *University of Hawaii, USA*
Edelgard Wulfert *New York State University, Albany, USA*
Thomas R. Zentall *University of Kentucky, USA*

International Journal of Psychology & Psychological Therapy is a four-monthly interdisciplinary publication open to publish original empirical articles, substantive reviews of one or more area(s), theoretical reviews, or reviews or methodological issues, and series of interest to some of the Psychology areas. The journal is published for the *Asociación de Análisis del Comportamiento* (AAC), indexed and/or abstracted in **SCOPUS**, **Google Scholar Metrics**, **ISOC** (CINDOC, CSIC), **PSICODOC**, Catálogo **Latindex**, **IN-RECS** (Index of Impact of the Social Sciences Spanish Journals), **PsycINFO**, **Psychological Abstracts**, **ClinPSYC** (American Psychological Association), **ProQuest**, **PRISMA**, **EBSCO Publishing Inc.**, **DIALNET**, and **RedALyC**.

International Journal of Psychology & Psychological Therapy es una publicación interdisciplinaria cuatrimestral, publicada por la Asociación de Análisis del Comportamiento (AAC), abierta a colaboraciones de carácter empírico y teórico, revisiones, artículos metodológicos y series temáticas de interés en cualquiera de los campos de la Psicología. Es publicada por la *Asociación de Análisis del Comportamiento* (AAC) y está incluida en las bases y plataformas bibliográficas: **SCOPUS**, **Google Scholar Metrics**, **ISOC** (CINDOC, CSIC), **PSICODOC** (Colegio Oficial de Psicólogos) **Latindex**, **IN-RECS** (Índice de Impacto de Revistas Españolas de Ciencias Sociales), **PsycINFO** (American Psychological Association) **ClinPSYC**, **ProQuest**, **PRISMA**, **EBSCO Publishing Inc.**, **DIALNET**, y **RedALyC** (Red de Revistas Científicas de América Latina y El Caribe, España y Portugal).

Differentiation between Defensive Personality Functioning and Psychopathology as Measured by the DSQ-42 and MMPI-2-RF

Louis De Page*

Mediter Psychotherapy Centre & Centre Hospitalier Jean Titeca, Belgium

Paul T van der Heijden

Reinier van Arkel Mental Health Institute & Radboud University, The Netherlands

Mercedes De Weerd

Vrije Universiteit Brussel (VUB), Belgium

Jos IM Egger

Radboud University & Vincent van Gogh Institute for Psychiatry, The Netherlands

Gina Rossi

Vrije Universiteit Brussel (VUB), Belgium

ABSTRACT

Defensive functioning is considered one of the core aspects of personality functioning and its maturity level is regarded an important predictor of psychopathology and more specific personality pathology. The current investigation assesses the relation between overall defensive functioning, as measured by the Defense Style Questionnaire-42 (DSQ-42), and higher order models of psychopathology as measured by the Minnesota Multiphasic Personality Inventory-2-Restructured Form (MMPI-2-RF). The DSQ-42 and MMPI-2-RF was completed by 383 patients. We analysed the MMPI-2-RF personality and psychopathology as measured with the Restructured Clinical scales and the Personality Psychopathology Five-revised scales using Goldberg's Bass Ackwards Method. Higher order dimensions of personality and psychopathology in the current investigation demonstrated structural similarity with previously reported higher order models. Next we examined the optimal level of differentiation of defensive functioning, as measured by the DSQ-42 Total and Overall Defensive Functioning scores, to personality and psychopathology at each succeeding level of the hierarchical factor structures. Results indicated that immature defense mechanisms exemplify strong correlations with internalizing pathology (i.e., Demoralisation and Introversion), but not with externalizing pathology and thought disorder. The differentiation of defensive functioning from higher order models of psychopathology and maladaptive personality traits seems to be limited, based on the current results. The DSQ-42 appeared to have a large overlap and correlations with internalizing pathology, which appeared to be due to its item content: mostly intrapsychic and immature defenses. Theoretical and clinical implications considering the use of the DSQ are discussed.

Key words: personality functioning, defense mechanism, DSQ-42, psychopathology, MMPI-2-RF.

How to cite this paper: De Page L, van der Heijden PT, De Weerd M, Egger JIM, & Rossi G (2018). Differentiation between Defensive Personality Functioning and Psychopathology as Measured by the DSQ-42 and MMPI-2-RF. *International Journal of Psychology & Psychological Therapy*, 18, 3, 331-343.

Novelty and Significance

What is already known about the topic?

- Despite the measurement challenges, defense mechanisms remain clinically relevant to assess.
- Higher-order models of psychopathology and personality pathology have been repeatedly supported.
- Defensive functioning is a core aspect of personality functioning as stated in Section III of the DSM-V.

What this paper adds?

- Examines convergences between defensive functioning, and psychopathology and personality pathology (MMPI-2-RF).
- Attempts to map defensive functioning on high-order models of psychopathology and personality traits.
- Explores the optimal level of differentiation of DSQ-42 and MMPI-2-RF scales at successive levels of psychopathology.

* Correspondence concerning this article should be addressed to: Louis De Page, Mediter Psychotherapy Centre, 69 Bergensesteenweg, 1500 Halle, Brussel, Belgium. Email: Louis.de.page@gmail.com

Although defensive mechanisms stem from psychoanalytic theory, research has led to their general acceptance (Cramer, 2010, 2015). They were included in the Diagnostic and Statistical Manual of Mental Disorders, fourth edition (DSM-IV; APA, 1994; Perry *et alii*, 1998), and were defined as “automatic psychological processes that protect the individual against anxiety and from the awareness of internal and external dangers or stressors. Individuals are often unaware of these processes as they operate” (DSM-IV; APA, 1994). The alternative model for personality disorders in DSM-V (APA, 2013) differentiates between A-type and B-type criteria referring to personality functioning and maladaptive personality traits. Bender, Morey, and Skodol (2011) referred to defensive functioning as a criteria for personality functioning. Over time, diverse concepts have been associated with maladaptive or disordered personality functioning, such as ineffectiveness, lack of empathy, impulsivity and many others (Parker *et alii*, 2002). Concepts such as defense mechanisms (e.g., Cramer, 2000; PDM Taskforce, 2006; Zimmerman, Ehrental, Cierpka, Schauenburg, Doering, & Benecke, 2012) and ego strength (Lake, 1985) have traditionally been considered core aspects of personality functioning. For instance, Millon stated that a systematic assessment of defense mechanisms “is central to a comprehensive personality assessment” (1984, p. 460).

Several authors have also described hierarchical models of psychological defenses; at the bottom level are primitive defenses such as delusional projection (usually of a persecutory nature) and splitting whereas at the top of the hierarchy, mature and socially adaptive forms are positioned such as humor and acceptance. Individuals’ characteristic level of defenses is correlated over time with mental health and different forms of psychopathology (e.g., Finzi-Dottan & Karu, 2006; Vaillant, 1971, 1992; Vaillant, Bond & Vaillant, 1986; Vaillant & McCullough, 1998). Immature defenses differentiate between the presence and the absence of a personality disorder (e.g., Birendra & Watson, 2004, Bond, 2004; Bond & Perry, 2004; Muris, Winands, & Horselenberg, 2003). Also, Kernberg has identified the maturity level of defensive functioning as one of the core characteristics of the structure of personality organization in that immature or primitive defenses are characteristic for borderline and psychotic personality organization (Kernberg, 1993). Further, defense mechanisms seem to have a unique role in addition to predominant affective temperament in the formation of depressive symptoms (Carvalho *et alii*, 2013), and, finally, the relation between therapeutic benefits (i.e., symptom relief) and defense use (i.e., use of more adaptive defenses) has been demonstrated in several clinical studies (e.g., Bond & Perry, 2004).

Several self-report measures to assess defense mechanisms have been developed. The value of these measures has been doubted (e.g., Cramer, 2000; Davidson & MacGregor, 1998; Funder & Colvin, 1988). Two points addressed by Andrews, Singh, & Bond (1993) may be supportive for the use of self-report assessment of defense mechanisms. First, they state that we are -in hindsight- often aware of the operations of unconscious processes and, secondly, they postulate that “the habitual use of any particular defense will leave tracks in an individual’s belief or attitude system and that endorsement of certain attitudes or beliefs can be taken as an indicator of the habitual use of that defense” (1993, p. 246).

One of the most widely used self-report measures of defense-mechanisms is the Defense Style Questionnaire (DSQ; Andrews *et alii*, 1993). The DSQ tradition has produced numerous versions with different items and items-to-defense ratios. Attempts to synchronize the DSQ with the DSM-III-R and DSM-IV DFS and recurrent psychometric problems of the DSQ instruments (such as the low item inter-correlation within defenses)

have encouraged researchers and clinicians to develop new versions (Andrews *et alii*, 1993; Wilkinson & Ritchie, 2015).

Despite the many versions of the DSQ and some of the problematic psychometric properties, a relatively robust three factor structure has been found across DSQ versions (e.g., Thysegen, Drapeau, Trijsburg, Lecours, & de Roten, 2008). The three factors are Immature, Neurotic and Mature defenses (cfr. *hereinunder*). In addition, an Overall Defensive Functioning (ODF) score has been developed by Trijsburg, Van 't Spijker, Van, Hesselink, and Duivenvoorden (2000). The ODF score is based upon a ranking by experts of the level of maturity of each DSQ defense mechanism. Higher ODF scores represent a higher overall maturity level of defensive functioning. Trijsburg *et alii* (2000) found that the ODF score is more appropriate for clinical use than the DSQ total score and the factor scores. For example, the ODF provides a unidimensional hierarchy of defensive mechanisms, the reliability of the ODF score is adequate, no items are lost in calculating the ODF score and the hierarchy of defense mechanisms is in accordance with psychoanalytical theory.

Furthermore, the DSQ has been related to several models of personality and psychopathology. For example, Sinha and Watson (1999) investigated the DSQ in relation to DSM-III-R personality disorders (PD). Results indicate that immature defenses are associated with the presence of personality pathology but specific PDs could not be predicted with the DSQ.

Mulder, Joyce, Sullivan, Bulik, and Carter (1999) also found a strong negative correlation for Immature defense style with Self-Directedness from Cloninger's psychobiological model of personality (Cloninger *et alii*, 1993).

Bond (2004) has reviewed empirical studies with the DSQ and finds strong evidence that adaptiveness of defense style correlates with mental health. As with personality pathology, immature defenses appear to be rather nonspecific in their associations with psychopathology, while mature defenses appear to be negatively correlated with any kind of psychopathology. Research has further demonstrated that the Immature factor is the most predictive factor of psychopathology (Bond, Paris, & Zweig-Frank, 1994; Hyphantis, 2010; Muris & Merckelbach, 1995).

In the current study, the relation between defensive functioning and psychopathology is investigated by linking the DSQ-42 (Trijsburg *et alii*, 2000) to the Minnesota Multiphasic Personality Inventory-2-Restructured Form (MMPI-2-RF; Ben-Porath & Tellegen, 2008). The DSQ-42 was chosen over other existing DSQ versions because of its ODF score (see above). The MMPI-2 (Butcher *et alii*, 1989) is one of the most widely used self-report instruments to assess psychopathology in clinical practice (Camara, Nathan, & Puente, 2000). The MMPI-2-RF provides an interesting measure for the evaluation of the DSQ-42 because it provides an integrative assessment of personality and psychopathology. Until now, most studies with the DSQ focus on relations with PDs as conceptualized in DSM-III or IV and on internalizing disorders such as depression (e.g., Grebota, Coffinet, & Laugier, 2008; Van, Dekker, Peen, Abraham, & Schoevers, 2009; Carvalho *et alii*, 2013), anxiety (e.g., Bond & Perry, 2004; Chavez Léon, del Carmen, & Uribe, 2006), and somatization (Hyphantis *et alii*, 2013). The MMPI-2-RF provides the possibility to link defense mechanisms to maladaptive personality traits (i.e., Personality Psychopathology Five, PSY-5-r), in line with the Alternative Model of Personality Disorders in Section III of DSM-V (e.g., Anderson *et alii*, 2013) as well as to higher order domains of psychopathology (i.e., the internalizing, externalizing and thought disorder spectra).

In the present investigation we first analyse correlations for the DSQ-42 total score, ODF score and factor scores (i.e., Immature, Neurotic and Mature defenses) with the MMPI-2-RF Higher Order (H-O) scales, Restructured Clinical (RC) scales and PSY-5-r scales. Then, Goldberg's (2006) "bass-ackwards" method was used to examine the hierarchical structure of pathological traits as measured by the PSY-5-r which was then correlated with the DSQ-42 ODF score to differentiate defense style as a measure of personality functioning from pathological trait components at succeeding levels of maladaptive personality trait hierarchy. Finally, the DSQ-42 ODF and Total score are related to successive levels of the higher order structure of psychopathology, as measured with the RC scales and derived using Goldberg's (2006) "bass-ackwards" approach. Optimal balance between differentiation and model parsimony was found between personality functioning and maladaptive personality traits using the same analyses (Bastiaansen, Hopwood, Van den Broeck, Rossi, Schotte, & DeFruyt, 2015). Again, the goal was examination of the potential to differentiate between domains of psychopathology at successive levels of the hierarchy and personality functioning as measured by the ODF score.

Studies linking the Defensive functioning and psychopathology and the MMPI-2 have revealed medium positive correlations between the DSQ-Immature factor and MMPI-2 Clinical scales 2 (Depression), 6 (Paranoia), 7 (Psychastenia), 8 (Schizophrenia), 9 (Hypomania) and 0 (Social Introversion) (Blaya *et alii*, 2007). The Mature factor demonstrated a small negative correlation with Clinical scale 2 (Depression) and a small positive correlation with Clinical scale 9 (Hypomania). Although the RC-scales demonstrate less intercorrelations than the Clinical scales (e.g., Van der Heijden, Egger, & Derksen, 2010) medium negative correlations for the Total DSQ score and the ODF score with all PSY-5-r scales and RC-scales are expected based upon findings by Blaya *et alii* (2007).

Based upon previous studies linking defenses and personality disorders (e.g. Birendra & Watson, 2004), we expect negative correlations between the ODF and mature defenses, and any of the PSY-5 scales. Conversely, we also expected positive correlation between the DSQ Total score and immature defenses, and any of the PSY-5 scales.

In line with Bastiaansen *et alii* (2015) and empirical findings reported by Bond (2004) we expect a moderate differentiation between defense style, pathological personality traits and psychopathology as measured by the DSQ, the PSY-5-r scales and the RC scales, respectively.

METHOD

Participants

The total sample was of 445 participants, of which 223 were inpatients (78%) and 62 outpatients (22%), from the Vincent van Gogh Institute for Psychiatry in Venray a teaching hospital located in The Netherlands. The mean age was 33.01 years at day of testing ($SD= 12.11$), 47% men and consists mostly of patients with multiple DSM diagnoses, including comorbid personality disorders. The total sample also included 160 outpatients (57% men) from Psychotherapy Centre Mediter in Halle (Belgium); their mean age was 36.31 years ($SD= 12.16$). This Belgium subsample consists of patients with personality problems and other mental disorders coming for (psychoanalytic) psychotherapy. Self-report questionnaires were administered at initial therapeutic stages. The total sample with inpatients and outpatients is chosen to represent a broad spectrum

of psychological and psychiatric problems including internalizing problems, antisocial behaviors, substance abuse disorders, and psychotic symptoms.

Measures and Instruments

DSQ-42 (Dutch language version, Trijsburg *et alii*, 2000). Trijsburg *et alii* (2000) added two additional items measuring repression to the existing 40 items, hence the DSQ-42. The 21 defense mechanisms measured by the DSQ-42 are: Acting out, Altruism, Anticipation, Autistic fantasy, Denial, Devaluation, Displacement, Dissociation, Humor, Idealization, Isolation, Passive aggression, Projection, Rationalization, Reaction formation, Repression, Somatization, Splitting, Sublimation, Suppression, and Undoing. The Belgian subsample used the DSQ-60 (Trijsburg, Bond, Drapeau, Thysegen, de Roten, & Duivendoorn, 2003), but DSQ-42 items were drawn out of the DSQ-60 version for this analyses. Because of this, the somatization defense (which is absent in the DSQ-60) was left out of the computation of the DSQ Total Score and ODF score of all protocols. Because of many item-level psychometric problems for the DSQ, we used (1) the total DSQ score, (2) three factor scores, and (3) the ODF (Trijsburg *et alii*, 2000). The total DSQ score was used because of its frequent use in the DSQ literature as a global score of defensive functioning. The factor scores were computed according to the results of Thysegen *et alii* (2008) and encompass 19 of the 21 defenses as follows: the immature factor (projection, passive aggression, acting-out, isolation, devaluation, autistic withdrawal, denial, displacement, dissociation, splitting and rationalization), the neurotic factor (undoing, altruism, idealization, reaction formation), and the mature style (humor, sublimation, anticipation, and suppression). The theoretical score range of the ODF score is from 1 to 7. The higher the score, the more mature is the overall level of defensive functioning. The ODF is computed by summing defense scores multiplied by an expert-derived maturity coefficient, divided by the raw sum of these defenses (for details, see Trijsburg *et alii*, 2000). For clarity's sake, we reversed the ODF score (ODFr) in order to obtain an immaturity score (to be correlated with "pathological" MMPI-2-RF scores).

MMPI-2-RF (Dutch-Flemish adaptation, Derksen, De Mey, Sloore, & Hellenbosch, 2006). The MMPI-2-RF scores were computed from administration of the MMPI-2 booklet. Tellegen and Ben-Porath (2008) and Van der Heijden, Egger, and Derksen (2010) confirmed comparability of scores derived from both booklets. Detailed information about the psychometric properties of the Dutch-language version of the MMPI-2-RF in the Dutch normative sample and clinical samples is provided by Van der Heijden *et alii* (2013). Only cases with valid MMPI-2-RF profiles (i.e., CNS <30, VRIN-r and TRIN-r *T* score <80, Fp-r *T* score <100 and L-r >80, Ben-Porath & Tellegen, 2008) were included.

Procedure and Data Analysis

The instruments were administered in accordance with the described procedures in the manuals. In accordance with the guidelines of the institutional review board, records were drawn from a large electronic database. For data analysis, patient identities were concealed. First, we report descriptive analyses of the DSQ Total score, factor scores, ODF, and *T*-scores for the MMPI-2-RF scales. We use raw scores in the further analyses. Internal consistency coefficients (Cronbach's alpha) were calculated for the DSQ total and factor scores and for the MMPI-2-RF H-O scales, RC scales and PSY-5-r scales. Then, zero-order correlations were calculated for the DSQ scores and all MMPI-2-RF scales. Only correlations that reached at least a medium effect size were interpreted ($r \geq .30$; Cohen, 1988) because of the possibility of artificially inflated correlations due to shared method variance. Differences in correlation magnitude were inspected using Fisher's z test. To explore the unfolding hierarchical structure of pathology, we applied Goldberg's (2006) "bass-ackwards" to the PSY-5-r and RC-scales. Both sets of scales

were subjected to a series of Principal Components Analyses (PCAs) with Varimax, beginning with only one, and proceeding until a component emerged, on which none of the included variables showed its highest loading. Regression-based factor scores from adjacent levels were correlated, and these correlations were interpreted as path coefficients. All path coefficients higher than .25 were used to delineate the unfolding structure. Next, for each level of the hierarchy, the pathological regression-based components that emerged at each successive level were correlated with the ODFr and the DSQ total score. The Pearson correlations at each level were averaged to obtain an index of overall overlap versus differentiation of the psychopathology components of the PSY-5-r and RC-scales and the DSQ ODFr/Total score. Next, Fisher's z was computed to compare each level's average correlation coefficient with the next level's average correlation coefficient. To estimate the effect size of the decrease in average correlation between the regression based factor scores and the ODFr across levels of the hierarchy, Cohen's q (1988) effect size was calculated. If the increase is below a small effect size (i.e., $q < .10$), the improvement in differentiation stagnates. In this way optimal balance between differentiation from the defensive functioning (ODFr and DSQ-42 Total score) and parsimony of the psychopathology model can be determined.

RESULTS

Table 1 presents scale names and abbreviations for all relevant scales as well as the range, mean scores and standard deviations and reliability statistics (i.e., Cronbach's α and mean inter item correlations). As Table 1 shows, all scales except the Neurotic and Mature defense scales demonstrate satisfactory reliability (i.e., $\alpha < .70$; Nunnally, 1970). Because of this, we dropped those factor scales from subsequent analyses. The DSQ total score and DSQ ODFr score demonstrate different patterns of correlations with the MMPI-2-RF (see Table 2). For example, the ODF score correlates stronger with EID than the DSQ Total score ($r = .63$ vs $r = .30$; $Z = -6.42$; $p < .01$; $q = -.43$), RCd ($r = .66$ vs $r = .37$; $Z = -6.01$; $p < .01$; $q = -.40$), RC2 ($r = .47$ vs $r = .06$; $Z = -6.69$; $p < .01$; $q = -.51$) and RC7 ($r = .56$ vs $r = .46$; $Z = -2.01$; $p < .05$; $q = -.14$) whereas the DSQ total score correlates stronger with RC3 ($r = .48$ vs $r = .37$; $Z = 2.00$; $p < .05$; $q = .13$). Overall, the ODF score exemplifies medium size correlations with the majority of MMPI-2-RF scales and strong correlations with internalizing scales. As expected, immature defenses showed the strongest correlations with the MMPI-2-RF scales whereas the mature style demonstrates small or inverse correlations with psychopathology and personality pathology.

Using Goldberg's bass-ackwards procedure, we arrived at a hierarchical structure of maladaptive personality as is presented in Figure 1. The apex of the hierarchy consists of a general factor of personality pathology, which was primarily defined by AGGR-r (.83), DISC-r (.76) and INTR-r (-.73). NEGE-r and PSYC-r had no significant loadings on this factor. At the second level, an externalizing factor emerged (explaining 36% of variance) that was defined by AGGR-r (.83), DISC-r (.76) and INTR-r (-.73) followed by an almost equal factor negative affectivity (explaining 30% of variance) defined by PSYC-r (.85) and NEGE-r (.85). At the third level, a narrower defined externalizing factor appeared, consisting of AGGR-r (.66) and DISC-r (.93). The second factor was almost equal to the second factor described above (i.e., negative affectivity with loadings of .86 and .85 for PSYC-r and NEGE-r respectively). The third factor (explaining 12% variance) is labelled positive affectivity (or introversion) and is defined by INTR-r (.94). The next level consisted of four factors that represent DISCR-r, INTR-r, NEGE-r and

Table 1. Descriptive and reliability statistics of the DSQ and MMPI-2-RF scales (N= 445).

	Items	Min	Max	Mean	SD	α	AIC
DSQ tot	40	85	269	183.17	30.89	.78	.11
ODFr	40	2.05	4.13	3.27	0.36	*	*
Immature	11 (22)	36	161	91.48	23.53	.76	.22
Neurotic	4 (8)	15	70	41.69	8.97	.41	.18
Mature	4 (8)	16	72	42.31	10.02	.58	.26
Emotional Internalizing Dysfunction (EID)	41	31	93	68.71	13.75	.92	.21
Thought Dysfunction (THD)	26	38	100	60.42	15.44	.83	.17
Behavioural Externalizing Dysfunction (BXD)	23	33	100	57.09	13.71	.81	.16
Demoralization (RCd)	24	37	88	69.23	13.02	.92	.33
Somatic Complaints (RC1)	27	35	98	61.38	15.02	.87	.20
Low Positive Emotions (RC2)	17	30	98	63.24	14.11	.74	.14
Cynicism (RC3)	15	30	86	52.60	11.53	.77	.18
Antisocial Behavior (RC4)	22	36	100	62.30	14.10	.78	.15
Persecutory Ideation (RC6)	17	39	100	60.22	15.24	.79	.19
Dysfunctional Negative Emotions (RC7)	24	34	100	65.23	15.22	.87	.21
Aberrant Experiences (RC8)	17	39	100	62.08	13.88	.79	.18
Hypomanic Activation (RC9)	28	31	96	53.33	12.83	.79	.12
Aggressiveness (AGGR-r)	18	30	86	48.77	11.34	.79	.17
Psychoticism (PSYC-r)	26	38	100	60.60	14.53	.82	.16
Disconstraint (DISC-r)	20	300	97	54.56	13.51	.75	.13
Neuroticism/ Negative Emotionality (NEGE-r)	20	33	96	66.07	12.76	.80	.16
Introversion/ Low Positive Emotionality (INTR-r)	20	32	900	55.43	13.60	.76	.20

Notes: DSQ tot= DSQ Total score; ODFr= reversed ODF score; *= Cronbach's alpha is not computed for the ODF because this is a ratio of scores multiplied by coefficients.

Table 1. Correlations between DSQ scales and the MMPI-2 HO, RC and PSY-5-r scales.

	dsq42total	ODFr	Immature	Neurotic	Mature
EID	.30*	.63**	.47*	.20	-.43*
THD	.41*	.39*	.45*	.25	-.10
BXD	.29	.18	.39*	.02	.16
RCd	.37*	.66**	.52**	.25	-.41*
RC1	.32*	.37*	.31*	.15	-.21
RC2	.06	.47*	.23	.06	-.46*
RC3	.48*	.37*	.47*	.20	-.05
RC4	.31*	.31*	.44*	.05	.00
RC6	.39*	.39*	.41*	.26	-.14
RC7	.46*	.56**	.50**	.33*	-.28
RC8	.39*	.39*	.45*	.20	-.09
RC9	.44*	.21	.46*	.12	.20
AGGR	.12	-.06	.17	-.11	.26
PSYC	.44*	.43*	.48*	.25	-.12
DISC	.21	.10	.30*	-.02	.19
NEGE	.44*	.52**	.48*	.28	-.25
INTR	-.07	.26	.06	-.01	-.34*

Notes: $r > .15$ is significant at $p < .05$; **= correlations with a large effect size (i.e. $\geq .50$); *= correlations with a medium effect size (i.e. $\geq .30$).

PSYC-r, with AGGR-r demonstrating almost equal absolute loadings on these four (i.e., .53; -.39; -.41 and .49 respectively). Finally the five PSY-5-r scales appeared.

Correlations between the ODFr and the factors at each successive level are presented in Table 3. Although the correlation coefficient of $r = .08$ ($p = .08$) between the ODFr and the first factor of the PSY-5-r scales might indicate nearly perfect differentiation, we nevertheless proceeded to subsequent levels of analysis because the ODFr score relates strongest to the internalizing personality scales such as NEGE-r (and with the factor that is labelled negative affectivity). The ODFr score appeared to differentiate until the second level. The DSQ Total Score outperformed the ODFr, and differentiated until level 3.

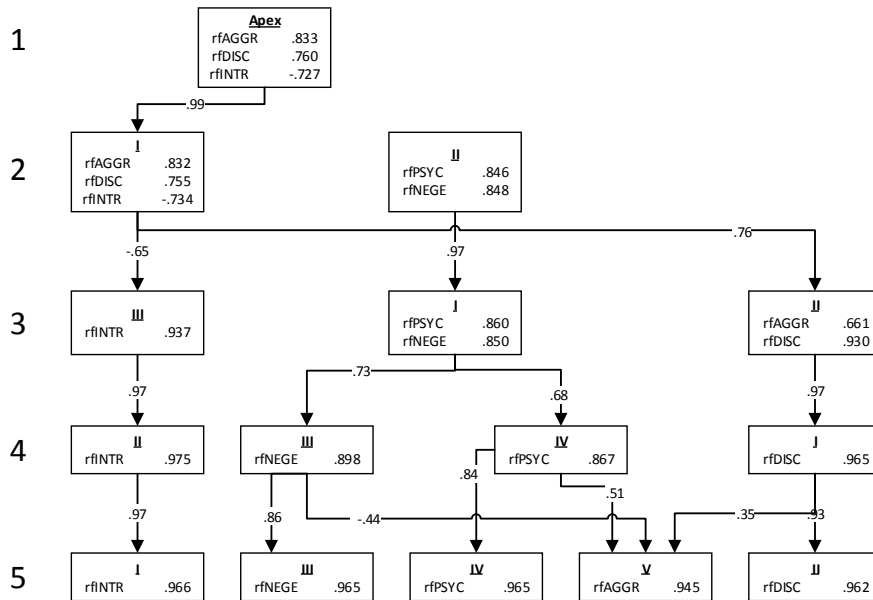

Figure 1. Hierarchical structure of the MMPI-2-RF PSY-5-r scales. Component numbers per level refer to the order of appearance in Principal Component Analysis results for that level. Arrows represent paths between levels. Values near arrows are correlations between factor scores and represent path coefficients. Only coefficients $\geq .25$ are displayed.

Table 3. Computations of optimal differentiation of DSQ ODF between successive levels of personality pathology hierarchy.

Level of hierarchy	Fact 1	Fact 2	Fact 3	Fact 4	Fact 5	M rl	Z	q
I	.08					.08		
II	-.10	.58				.34	.35	.27
III	.53	.08	.25			.29	.30	.05
IV	.01	.24	.45	.30		.27	.28	.02
V	.24	.11	.43	.32	-.04	.23	.23	.05

Notes: M|rl= mean absolute correlation; q= Cohen's q.

Figure 2 presents a hierarchical structure of psychopathology as measured by the RC scales. The general factor at the first level, explaining 45% of the variance comprises 6 out of the 9 RC scales (i.e., RCD, RC1, RC3, RC6, RC7 en RC8 with loadings $\geq .67$). The second level represents the Internalizing (RCd, RC1, RC2, RC7; factor loadings $\geq .70$) and Externalizing factors. The externalizing factor explains 20% variance. RC9 has the strongest loading (i.e., .87), followed by RC4 (.73), RC3 (.64) and RC8 (.61). Both of these factors are roughly the same at the third level. However, a thought disorder factor emerges at the third level consisting of RC8 (.80), RC6 (.77) and RC1 (.74), explaining 9% of the variance. At the next level RC3 appears as a separate factor and in succession RC1, RC9/RC4, RC6/RC8 and RC2 and finally RC7/RCd appear as separate factors. The ODF appears to discriminate until level two and does not appear to have an incremental differential value afterwards (see Table 4). The DSQ Total score exemplifies a similar pattern.

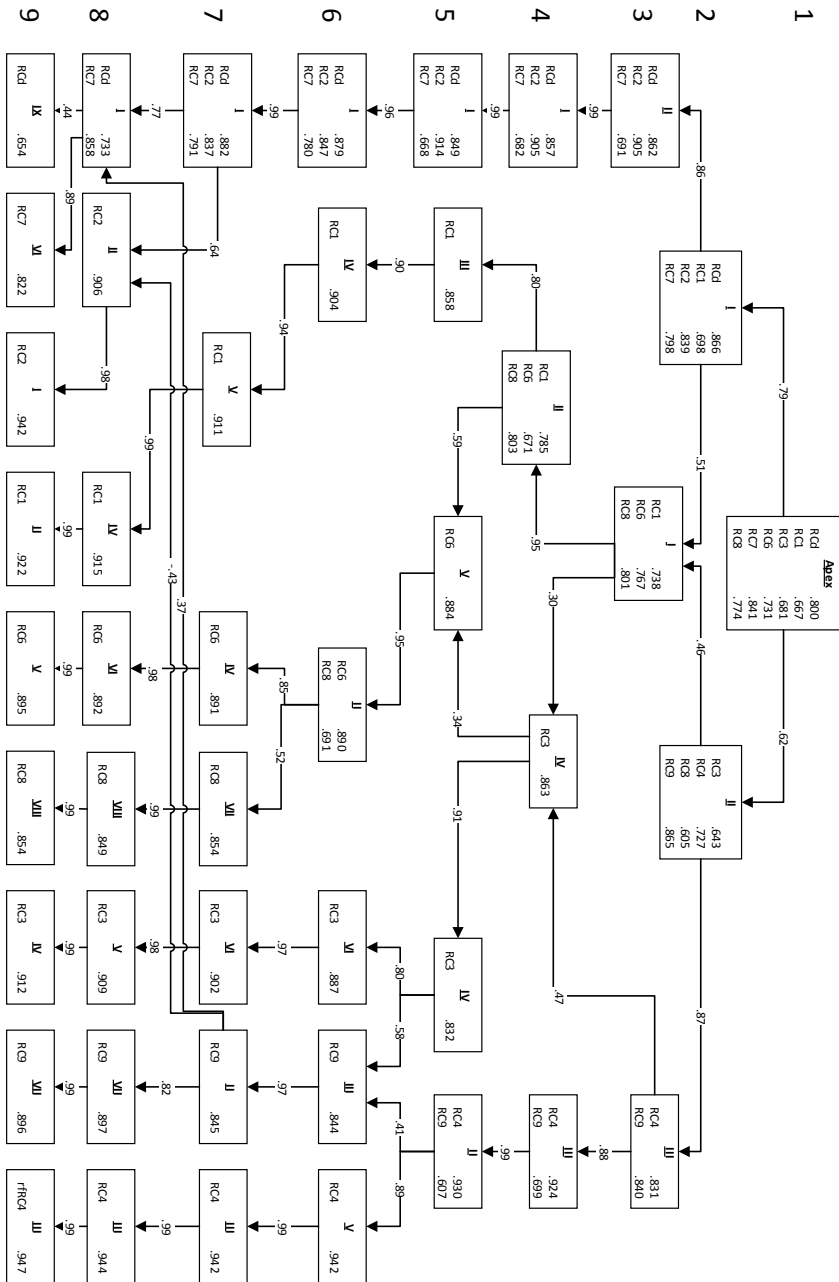

Figure 1. Hierarchical structure of the MMP-2-RF RC-scales. Component numbers per level refer to the order of appearance in Principal Component Analysis results for that level. Arrows represent paths between levels. Values near arrows are correlations between factor scores and represent path coefficients. Only coefficients $\geq .25$ are displayed.

Table 4. Computations of optimal differentiation of DSQ ODF between successive levels of psychopathology hierarchy.

Level of Hierarchy	Fact 1	Fact 2	Fact 3	Fact 4	M rl	Z	q
I	.63				.63	.74	
II	.58	.27			.43	.46	.28
III	.27	.56	.27		.37	.38	.07
IV	.55	.25	.23	.20	.31	.32	.07

Notes: M|rl= Mean Absolute Correlation, q= Cohen's q.

DISCUSSION

In this study, we investigated associations between defensive functioning (as measured by the DSQ), and maladaptive personality traits and higher order factors of psychopathology as measured by the MMPI-2-RF. Correlation patterns between the DSQ and MMPI-2-RF scales are as theoretically expected; medium to strong correlations for immature defense mechanisms with all RC-scales except RC2. As expected, the DSQ exemplifies stronger associations with internalizing pathology (particularly RCd) than with externalizing pathology. The ODF can be differentiated to some extent from maladaptive personality traits and psychopathology and therefore might have limited incremental validity in the assessment of personality and psychopathology.

The ODF score exemplifies stronger and more consistent relations with internalizing pathology (and demoralization) than the DSQ Total score. The DSQ Total score is considered to be a measure of maladaptive defensive functioning, but in fact it is an unweighted sum of item scores on both adaptive and immature defenses. Knowing that immature defenses are overrepresented in all DSQ versions (in comparison to mature defenses), the most mature or adaptive defense score one could obtain, is the minimum score on every defense, even the adaptive ones. The DSQ Total Score thus reflects a vague indication of the number of different reported defenses instead of a measure of adaptiveness. Clearly, balanced or weighted measures such as the ODF score as an indication of adaptiveness of defensive functioning are to be preferred.

The strong correlation of the ODF with RCd is interesting. Demoralization is defined as a 'trait like characteristic' (Tellegen *et alii*, 2003, p. 13) that involves at least two dimensions: distress and subjective incompetence to deal with the distress. These results demonstrate that the ODF score reflects a broad dimension that is linked to adaptive functioning and the ability to cope with stress. The ODF score might also be considered as a trait like characteristic, as the wording of (some of) the items implies consistency over time (e.g., "I always feel that someone I know is like a guardian angel"; see Bond, 2004). At the same time, it is known that the adaptiveness of defenses is related to the context in which they occur and is also related to other characteristics of patients such as age (e.g., Cramer, 2000). Also, patients might develop more adaptive defense mechanisms during treatment (Bond & Perry, 2004), although changes in defense style and (simultaneous) symptom relief is no evidence for a causal relation.

The investigation of higher order domains of the PSY-5-r scales resembles the hierarchical structures found by Wright *et alii* (2012) of DSM-V pathological personality traits and Bastiaansen *et alii* (2015) with the DAPP-BQ. The hierarchical structure of psychopathology with the RC scales resembles earlier results with the RC scales in different samples by Sellbom, Ben-Porath, and Bagby (2008) and Van der Heijden,

Rossi, Van der Veld, Derksen, & Egger (2013). Clearly, the ODF score exemplifies strong associations with internalizing pathology and could hardly be differentiated from internalizing (personality) pathology. The lack of association between the DSQ variables and the MMPI-2-RF externalizing scales might be due to the overrepresentation of intrapsychic defense mechanisms in the DSQ. Even the immature factor scores contain a majority of intrapsychic defenses such as denial, projection, splitting or dissociation. Only two behavioural/externalizing defense mechanisms are included in the DSQ: Passive aggression and acting-out. Previous versions of the DSQ also included substance consumption, aggression, somatization, lying, or hypochondria, which might have had stronger association with behavioural/externalizing scales. Strictly speaking, one might say that externalizing pathology implies the failing of intrapsychic defenses.

Defensive functioning has been regarded as a relevant or even essential concept in personality assessment (e.g., Cramer, 2000; Millon, 1984). Current results demonstrated considerable overlap between defensive functioning, demoralization and internalizing pathology. Therefore, the incremental validity of defensive functioning might be limited. On the other hand, correlations between the ODF and internalizing pathology in the current investigation may be inflated due to single method variance. And still, the ODF might be an interesting concept to evaluate in personality assessment as it will probably be more sensitive to (personality) change during psychotherapy than maladaptive personality traits as measured with the PSY-5-r.

A clear limitation of the current investigation is the single method variance, and the sole reliance on self-reported defense mechanisms. Therefore, future research should investigate defensive functioning by means of systematic clinical assessment procedures such as the Defense Mechanism Rating Scale (Perry, 1990). In addition, an interesting direction for future research is the incremental validity of defensive functioning above maladaptive personality traits in predicting treatment outcomes. And, of course (as the interest in defense mechanism goes up and down during history), relations between defensive functioning and the level of personality functioning as conceptualized in Section III of DSM-V can be an interesting direction for further research.

REFERENCES

- APA (1994). *Diagnostic and statistical manual of mental disorders* (4th Ed.). Washington, DC: American Psychiatric Association.
- APA (2013). *Diagnostic and statistical manual of mental disorders* (5th Ed.). Washington, DC: American Psychiatric Association.
- Anderson JL, Sellbom M, Bagby RM, Quilty LC, Veltri COC, Markon KE, & Krueger RF (2013). On the convergence between PSY-5 domains and PID-5 domains and facets: Implications for assessment of DSM-5 personality traits. *Assessment*, 20, 286-294.
- Andrews G, Singh M, & Bond M (1993). The Defense Style Questionnaire. *Journal of Nervous and Mental Disease*, 181, 246-256. Doi: 10.1097/00005053-199304000-0000
- Bastiaansen L, Hopwood CJ, Van den Broeck J, Rossi G, Schotte C, & De Fruyt F. (2016). The Twofold Diagnosis of Personality Disorder: How Do Personality Dysfunction and Pathological Traits Increment Each Other at Successive Levels of the Trait Hierarchy? *Personality Disorders: Theory, Research, and Treatment*, 7, 280-292. Doi: 10.1037/per0000149
- Bender DS, Morey LC, & Skodol AE (2011). Toward a model for assessing level of personality functioning in DSM-5, part I: A review of theory and methods. *Journal of Personality Assessment*, 93, 332-346.
- Ben-Porath YS & Tellegen A (2008). *MMPI-2-RF user's guide for reports*. Minneapolis: University of Minnesota Press.
- Birendra KS & Watson DC (2004). Personality disorder clusters and the defense style questionnaire. *Psychology and Psychotherapy: Theory, Research and Practice*, 77, 55-66.

- Blaya C, Dornelles M, Blaya R, Kipper L, Heldt E, Isolan L, Manfro GG, & Bond M (2007). Brazilian-Portuguese version of defensive style questionnaire-40 for the assessment of defense mechanisms: construct validity study. *Psychotherapy Research, 17*, 261-270.
- Bond M (2004). Empirical studies of defense style: Relationships with psychopathology and change. *Harvard Review of Psychiatry, 12*, 263-278.
- Bond M, Paris J, Zweig-Frank H (1994). Defense styles and borderline personality disorder. *Journal of Personality Disorders, 8*, 28-31.
- Bond M & Perry JC (2004). Long-term changes in defense style with psychodynamic psychotherapy for depressive, anxiety and personality disorders. *American Journal of Psychiatry, 161*, 1665-1671
- Butcher JN, Dahlstrom WG, Graham JR, Tellegen A, & Kaemmer B (1989). *Minnesota Multiphasic Personality Inventory-2 (MMPI-2): Manual for administration and scoring*. Minneapolis: University of Minnesota Press.
- Camara WJ, Nathan JS, & Puente AE (2000). Psychological test usage: implication in professional psychology. *Professional Psychology: Research and Practice, 31*, 141-154.
- Carvalho AF, Hyphantis TN, Taunay TC, Macêdo DS, Floros GD, Ottoni GL, Konstantinos NF, Lara DR (2013). The relationship between affective temperaments, defensive styles and depressive symptoms in a large sample. *Journal of Affective Disorders, 146*, 58-65.
- Chávez León E, Lara Muñoz MC, & Uribe MPO (2006). An empirical study of defense mechanisms in panic disorder. *Salud Mental, 29*, 15-22.
- Cloninger CR, Svrakic DM, & Przybeck TR (1993). A psychobiological model of temperament and character. *Archives of General Psychiatry, 50*, 977-991.
- Cohen J (1988). *Statistical power analysis for the behavioral sciences* (2nd Ed.). Hillsdale, NJ: Erlbaum.
- Cramer P (2000). Defense mechanisms in psychology today: Further processes for adaptation. *American Psychologist, 55*, 637-646. Doi: 10.1037/0003-066X.55.6.637
- Cramer P (2015). Defense mechanisms: 40 years of empirical research. *Journal of Personality Assessment, 97*, 114-122.
- Davidson K & MacGregor MW (1998). A critical appraisal of self-report defense mechanism measures. *Journal of Personality, 66*, 965-992. Doi: 10.1111/1467-6494.00039
- Derksen J, De Mey H, Sloore H, & Hellenbosch G (2006). *MMPI-2: Handleiding bij afname, scoring en interpretatie. Tweede, gewijzigde uitgave* [Minnesota Multiphasic Personality Inventory-2: Manual for administration, scoring, and interpretation]. Nijmegen, The Netherlands: PEN Test Publishers.
- Finzi-Dottan R & Karu T (2006). From emotional abuse in childhood to psychopathology in adulthood: a path mediated by immature defense mechanisms and self-esteem. *Journal of Nervous and Mental Disease, 194*, 616-621.
- Funder DC & Colvin CR (1988). Friends and strangers: Acquaintanceship, agreement, and the accuracy of personality judgment. *Journal of Personality and Social Psychology, 55*, 149-158.
- Goldberg LR (2006). Doing it all Bass-Ackwards: The development of hierarchical factor structures from the top down. *Journal of Research in Personality, 40*, 347-358.
- Grebota, E., Coffinet, A., & Laugier, C. (2008). Changes during detoxification: Depression, hopelessness, defense mechanisms and beliefs. *Journal de Thérapie Comportementale et Cognitive, 18*, 77-83.
- Hyphantis T (2010). The Greek version of the Defense Style Questionnaire: Psychometric properties in three different samples. *Comprehensive Psychiatry, 51*, 618-629.
- Hyphantis TN, Taunay TC, Macedo DS, Soeiro-de-Souza MG, Bisol LW, Fountoulakis KN, Lara DR, & Carvalho AF (2013). Affective temperaments and ego defense mechanisms associated with somatic symptom severity in a large sample. *Journal of Affective Disorders, 150*, 481-489. Doi: 10.1016/j.jad.2013.04.043
- Kernberg OF (1993). *Severe personality disorders: Psychotherapeutic strategies*. New Haven: Yale University Press.
- Lake B (1985). Concept of ego strength in psychotherapy. *British Journal of Psychiatry, 147*, 471-478.
- Millon T (1984). On the renaissance of personality assessment and personality theory. *Journal of Personality Assessment, 48*, 450-466.
- Mulder RT, Joyce PR, Sullivan PF, Bulik CM, Carter FA (1999). The relationship among three models of personality psychopathology: DSM-III-R personality disorder, TCI scores and DSQ defenses. *Psychological Medicine, 29*, 943-951.
- Muris P, Winands, D., & Horselenberg, R. (2003). Defense styles, personality traits, and psychopathological symptoms in nonclinical adolescents. *Journal of Nervous and Mental Disease, 191*, 771-780.
- Muris P & Merckelbach H (1996). The short version of the Defense Style Questionnaire: Factor structure and psychopathological correlates. *Personality and Individual Differences, 20*, 123-126.

- Nunnally J (1978). *Psychometric theory* (2nd Ed.). New York: McGraw-Hill.
- Parker G, Both L, Olley A, Hadzi-Pavlovic D, Irvine P, & Jacobs G (2002). Defining disordered personality functioning. *Journal of Personality Disorders, 16*, 503-522.
- PDM Taksforce (2006). *Psychodynamic Diagnostic Manual*. Silver Spring, MD: Alliance of Psychoanalytic Organizations.
- Perry JC (1990). *Defense mechanism rating scale*. Cambridge, MA: Harvard School of Medicine.
- Perry JC, Høglend P, Shear K, Kardos M, Vaillant G, Horowitz M, Bille H, Winkelman E, & Kagan D (1998). Field trial of a diagnostic axis for defense mechanisms for DSM-IV. *Journal of Personality Disorders, 12*, 56-68
- Sellbom M, Ben-Porath YS, & Bagby RM (2008). Personality and Psychopathology: Mapping the MMPI-2 Restructured Clinical (RC) scales onto the Five Factor Model of personality. *Journal of Personality Disorders, 22*, 291-312.
- Sinha BK & Watson DC (1999). Predicting personality disorder traits with the Defense Style Questionnaire in a normal sample. *Journal of Personality Disorders, 13*, 281-286.
- Tellegen A & Ben-Porath YS (2008). *MMPI-2-RF technical manual*. Minneapolis: University of Minnesota Press.
- Thyssen KL, Drapeau M, Trijsburg RW, Lecours S, & de Roten Y (2008). Assessing Defenses Styles: Factor Structure and Psychometric Properties of the New Defense Styles Questionnaire 60 (DSQ-60). *International Journal of Psychology and Psychological Therapy, 8*, 171-181
- Trijsburg R, Bond M, Drapeau M, Thygesen K, de Roten Y, & Duivenvoorden H (2003). *Defense Style Questionnaire 60: Development and psychometric evaluation*. University of Lausanne: Lausanne, Switzerland.
- Trijsburg RW, van t' Spijker A, Van HL, Hesselink AJ, & Duivenvoorden HJ (2000). Measuring overall defensive functioning with the Defense Style Questionnaire: A comparison of different scoring methods. *Journal of Nervous and Mental Disease, 188*, 432-439. Doi: 10.1097/00005053-200007000-00007
- Vaillant GE (1971). Theoretical hierarchy of adaptive ego mechanisms: A 30-year follow-up of 30 men selected for psychological health. *Archives of General Psychiatry, 24*, 107-118.
- Vaillant GE (1992). *Ego mechanisms of defense: A guide for clinicians and researchers*. Washington, DC: American Psychiatric Press.
- Vaillant GE, Bond, M., Vaillant, CO. (1986). An empirically validated hierarchy of defense mechanisms. *Archives of General Psychiatry, 43*, 786-794.
- Vaillant GE & McCullough L (1998). The role of ego mechanisms in the diagnosis of personality disorders. In JW Barron (Ed.) (1998). *Making diagnosis meaningful: Enhancing evaluation and treatment of psychological disorders* (pp. 139-158). Washington, DC: American Psychological Association.
- Van HL, Dekker J, Peen J, Abraham RE, & Schoevers R (2009). Predictive value of self-reported and observer-rated defense style in depression treatment. *American Journal of Psychotherapy, 63*, 25-39.
- Van der Heijden PT, Egger JIM, & Derksen JJL (2010) Comparability of Scores on the MMPI-2-RF Scales Generated with the MMPI-2 and MMPI-2-RF Booklets. *Journal of Personality Assessment, 92*, 254-259.
- Van der Heijden PT, Derksen J, Egger JIM, Rossi GMP, Laheij M, & Bögels T (2013). *Minnesota Multiphasic Personality Inventory-2-Restructured Form. Handleiding voor afname, scoring en interpretatie*. Nijmegen: PEN Test Publisher.
- Van der Heijden PT, Rossi GMP, Van der Veld WM, Derksen JJL, & Egger JIM (2013). Personality and psychopathology: Higher order relations between the Five Factor Model of personality and the MMPI-2 Restructured Form. *Journal of Research in Personality, 47*, 572-579.
- Verheul R, Andrea H, Berghout CC, Dolan C, Busschbach JJV, Van der Kroft PJA, Petra JA, Bateman A, & Fonagy P (2008). Severity Indices of Personality Problems (SIPP-118): Development, factor structure, reliability, and validity. *Psychological Assessment, 20*, 23-34. Doi: 10.1037/1040-3590.20.1.23
- Wilkinson W & Ritchie T (2015). The dimensionality of defense-mechanism parcels in the Defense Style Questionnaire-40 (DSQ-40). *Psychological Assessment, 15*, 1-6.
- Wright AG, Thomas KM, Hopwood CJ, Markon KE, Pincus AL, & Krueger RF (2012). The hierarchical structure of DSM-5 pathological personality traits. *Journal of Abnormal Psychology, 121*, 951-957. Doi: 10.1037/a0027669
- Zimmermann J, Ehrental JC, Cierpka M, Schauenburg H, Doering S, & Benecke C (2012). Assessing the level of structural integration using Operationalized Psychodynamic Diagnosis (OPD): Implications for DSM-5. *Journal of Personality Assessment, 94*, 522-532.

Received, May 16, 2018
Final Acceptance, July 9, 2018