

Artículos / Articles

Corruption Perceptions, Political Distrust, and the Weakening of Political Islam in Iraq

Percepciones de la corrupción, desconfianza política, y el debilitamiento del Islam político en Irak

Mahmoudreza Rahbarqazi 
University of Isfahan, Iran
m.rahbarqazi@ase.ui.ac.ir

Raza Mahmoudoghli 
University of Mohaghegh Ardabili, Iran
r_oghli@uma.ac.ir

Received / Recibido: 01/02/2020
Accepted / Aceptado: 21/05/2020



ABSTRACT

Employing the SEM technique, the present study aims to examine the effects of corruption perceptions on political distrust and political Islamization in Iraq. The present study used the Arab Barometer Wave V data provided during 2018–2019. By examining data from 2461 Iraqi citizens, the results revealed that corruption perceptions, on the one hand, increase citizens' perceptions of poor government performance and wrong direction of the country, and it reduces the tendency for a democratic political system on the other hand. The results also showed that citizens' perceptions of corruption indirectly, through the above three mediating variables, increase political distrust in society and negatively affect political Islamization. Citizens' corruption perceptions, therefore, appear to be one of the important reasons that challenge the public's confidence in the institutions and the ruling political ideology.

Keywords: corruption perceptions, support for democracy, political distrust, political Islam, Iraq.

RESUMEN

Empleando la técnica SEM, el presente estudio tiene como objetivo examinar los efectos de las percepciones acerca de la corrupción sobre la desconfianza en la política y en el islamismo político en Irak. El presente estudio utilizó los datos de la quinta oleada del Arab Barometer proporcionados durante los años 2018-2019. Examinando los datos proporcionados por 2461 ciudadanos iraquíes, los resultados revelaron que la percepción de corrupción que, por un lado, aumenta la percepción de la ciudadanía de un desempeño deficiente del gobierno y una mala dirección del país y, por otro lado, reduce la tendencia a un sistema político democrático. Los resultados también mostraron que las percepciones de los ciudadanos sobre la corrupción, a través de las tres variables mediadoras mencionadas, indirectamente aumentan la desconfianza política en la sociedad y afectan negativamente a la islamización política. Las percepciones de corrupción de la ciudadanía, por lo tanto, parecen ser una de las razones clave que desafían la confianza del público en las instituciones y en la ideología política del gobierno.

Palabras clave: percepción de la corrupción, apoyo a la democracia, desconfianza política, Islam político, Irak.

*Autor para correspondencia / Corresponding author: Mahmoudreza Rahbarqazi, m.rahbarqazi@ase.ui.ac.ir
Sugerencia de cita / Suggested citation: Rahbarqazi, M., Mahmoudoghli, R. (2020). Corruption Perceptions, Political Distrust, and the Weakening of Political Islam in Iraq. *Revista Española de Sociología*, 29 (3, supl. 1), 57-74. <https://doi.org/10.22325/fes/res.2020.57>

INTRODUCTION

Corruption is a serious global phenomenon that is widely observed in developed and developing countries. Surveys show that countries with a democratic socio-economic structure and institutional arrangements are likely to experience less corruption and that corruption is predominantly in non-democratic countries and with less controlling institutions (Doorenspleet, 2019). Thus, the problems of corruption in societies, especially developing countries, and its impact on the legitimacy and efficiency of political systems have been the focus of academics and professionals (Barkemeyer et al., 2018; Desta, 2019).

In this regard, some scholars regard corruption as a general disease of the political community that can destroy the social and cultural-political structure of societies (Terziev & Petkov, 2017). Others argue that corruption distorts public policy and leads to uneven allocation of economic resources (Dincer & Gunalp, 2012). According to Transparency International's report, corruption is the abuse of public power for personal gain (Budsaratragoon & Jitmaneeroj, 2020). Corruption refers to "the deliberate neglect or neglect of a recognized duty, or the unjustified exercise of power, with the motive to gain advantage" (Ledeneva, 2009).

Jancsics (2014) examined corruption from three views: the first is the micro view according to which corruption is the result of the rational decisions of individual actors. This view understands corrupt individuals in the organization as rational actors who have perpetrated corruption based on their interests (Ashforth et al., 2008; Kish-Gephart et al., 2010). The second is the macro view which focuses on social norms and structural arrangements that facilitate corruption. According to the macro view, corruption is a phenomenon that is embedded in a larger social structure (Nuijten & Anders, 2007). Based on this approach, people from countries with high levels of corruption tend to be more likely to break the law (Barr & Serra, 2010; Fisman & Miguel, 2008). The third is the relational view that examines social interactions and networks between actors in corruption. According to this view, corruption is the product of the informal exchange network behind the formal organizational structure (Jaskiewicz et al., 2013; Granovetter, 2007).

Although some scholars believe that corruption acts as the "wheel oil" of development in developing countries, it appears that the political and social consequences of corruption - the subject of this study - can be undesirable (Chen et al., 2007). In this regard, many scholars have pointed to the negative effects of the perception of corruption on political phenomena, including political distrust and diminished citizen support for ideology and governing structures (Wang, 2016; Etzioni-Halevy, 2013; Anderson & Tverdova, 2003). But such research has been less common in Middle Eastern societies.

The significance of the Middle East is that a lot of its countries are first and foremost oil-leasing ones, and secondly, such economic structures, together with the absence of civil society institutions, create a more favorable environment for corruption. This seems to have caused most citizens in the Middle East to have a strong political distrust of the rulers and structures in their country and to respond occasionally to violent uprisings. Accordingly, one of the countries where corruption in the Middle East has caused many problems in different fields is Iraq (Abdullah, 2017; Sawaan, 2012). As reports released by the Corruption Perceptions Index (CPI) show, Iraq is ranked 168th in the world in 2018 with corruption perceptions score as 18. Based on existing theories it may probably affect citizens' views of institutions. And political ideologies will have a negative effect. Importantly, Iraq has many similarities in terms of economic, historical, and cultural structures with other countries in the region, making it likely that the findings of this study may be generalizable to other countries in the Middle East.

This article is organized as follows: In the first section, it examines the theoretical approach to the study of political corruption perceptions, trust, and ideology of political Islam. Next, it describes the data and the method used to do the empirical analysis. In the next step, after presenting and interpreting the results of the tested models, it discusses the crucial significance of our findings. Finally, it summarizes the results and provides some questions and suggestions for future research.

THEORETICAL FRAMEWORK

Experimental studies show that corruption undermines the legitimacy of the political system by directly affecting government efficiency, affecting the quality of government, trust, public support, satisfaction, and ultimately the stability of democracy. Corruption distorts economic decision-making and processes, poses a threat to trust, and endangers the legitimacy of the political system (Gray & Kaufman, 1998; Mauro, 1995; Morris & Klesner, 2010; Rothstein & Eek, 2009). Activists see the corrupt system and abuse of power; this increases the demand for illegal and corrupt practices, so corruption is a threat to trust. Uslaner (2005) showed that corruption leads to government inefficiencies, tax evasion, sluggish economic growth, widespread inequality, and political instability.

Some studies indicate that political confidence is declining in the United States and Western Europe. Similarly, political confidence in emerging democracies has also been declining in recent decades. The decline in political confidence can indicate a decline in the health of the political system so that the decline in the health of the political system as part of the reasons for political cynicism and civil indifference can affect the quality of global democracy (Putnam, 2000). In this regard, many scholars have addressed the causes of political distrust. But one of the theoretical explanations in this regard is the institutional theories that discuss the origin of political trust. Institutional theory, as opposed to other theories, including cultural theories, views political trust as inward as a result of institutional functioning. The institutional approach is based on a rational choice perspective and recognizes that political confidence stems from individuals' wise responses to the performance of political institutions. Proponents of this theory emphasize the importance of government performance and the results of their policymaking. To increase political confidence, governments must be able to provide good and meaningful policymaking to the people (Mishler & Rose, 2001).

In this regard, it seems that corruption in three ways can create political distrust in society. First, current research suggests that government performance can affect political trust. Studies reveal that the political and economic performance of governments is the major factor in increasing or decreasing political confidence. Good government performance leads to higher levels of trust, whereas weak performance leads to lower levels of trust (Coleman, 1990; Hetherington, 1998; Hudson, 2006). It should be noted, of course, that people's assessment of government performance can explain the variance of political trust, but we should not neglect the role of probity as an influential variable on political trust.

Several studies show that corruption within governments, and in particular the political one, can permanently reduce political confidence. The reason is that political corruption undermines the proper functioning of political institutions. Lee (1994) indicates how people's perceptions and thinking can influence their behavior towards politicians and political trust. If people feel that politicians are incompetent and failing to fulfill their responsibilities, a negative attitude towards them will develop. Corruption diminishes confidence in the regime's ability to respond to citizens' concerns (Morris & Klesner, 2010).

Michael Seligson (2006) examined the cost of corruption in four Latin American countries by examining the relationship between corruption and the legitimacy of political systems in these countries and has shown that the spread of corruption reduces the legitimacy of governments and affects the relationship between people and the level of public trust.

Corruption perceptions harm trust in political institutions, while the experience of corruption undermines public confidence in national institutions. Also, corruption perceptions reinforce the lack of trust and lack of trust undermines the government's efforts to mobilize society to fight corruption and discredits the promise of fighting corruption. Therefore, there is a strong interplay between the perception of corruption and trust in political institutions. Anderson and Tverdova (2003) examined the effect of corruption on people's attitudes to the government in 16 democracies and found that people in the countries with higher levels of corruption rated the performance of the political system more negatively.

La Porta and et al. (2000) argued that corruption impedes state action and diminishes citizens' trust in the governments' ability to address their demands. Corruption both distorts the public interest and focuses resources and administrative activities on areas where the peripheral benefits of corruption are greatest. Morris and Kelsner (2010) discovered a strong reciprocal causality between perceptions of corruption and trust in political institutions, using American Barometer Survey Political Trust Data and Perception and Survey of Corruption Experience. They showed that participation in corruption is the only predictor of lower levels of interpersonal trust. In their findings, when interpersonal trust is considered as the dependent variable, none of the independent variables (experience and perception of corruption) predict the interpersonal trust. But there is a negative and negative relationship between corruption perceptions and political trust.

Moreover, the lack of trust in political institutions may contribute to the emergence of populist and/or extremist political forces. If citizens identify democracy with incompetence, injustice, and corruption, they are likely to undermine the value of democracy and may be inclined to adopt alternative forms of undemocratic government approach (Choi, 2014). Alesina and Angeletos (2005) argue that when income inequality and injustice are created by corruption, the poor advocate a redistribution policy that seeks to create inequality and injustice, and that the rich can support it because they can extract more rent from subsidy policies. Clientelist systems spread out corruption in society by expanding illegal political and administrative relations. In these systems, lobbying, bribery, extortion, and embezzlement are increasing in society. Some political groups that have more political influence over the government have more opportunities to earn rents, which undermines democratic values and thus reduces citizens' trust in the ruling political institutions (Nelson, 2012; Posada & Walter, 1996).

In addition to the main political issues, there is also a relationship between trust in political input and economic issues. One of the most well-known arguments is that the reason people are willing to pay taxes is that they trust the government to provide services and public goods. Entrepreneurs' willingness to invest and participate in various types of economic activity depends partly on their trust in the government for executing contracts and punishing offenders (Kuokstis, 2012). Kuokstis (2012) examined the financial performance of Estonia and Lithuania over the years 2007–2008 and found that higher tax collection efficiency in Estonia was created by high public confidence in government performance.

The second way is the effect of citizens' corruption perceptions on their political distrust through the creation of barriers to democratic culture. Corruption can harm democracies by undermining the fragile balance between institutions, laws, and norms that provide the system with trust and legitimacy. Moreno (2002) showed that the permissibility of corruption- known as the tendency to justify acts of corruption in society- is negatively correlated with democratic attitudes and political trust.

Choi (2014) indicated that political corruption and political trust affect each other and they in turn influence citizens' beliefs about democratic values and processes. Drapalova (2019) believed that corruption in five ways can affect democracy. According to him, corruption first infects the democratic electoral system and thus attacks the heart of democracy. Others also argued that corruption in the form of electoral fraud and vote-buying is one of the most widespread forms of political corruption that some corrupt political officials try to remain in power in this way (Ziblatt, 2009). Second, corruption can prevent some people from engaging in political participation by increasing discrimination against minorities, social classes, and women (Goldberg, 2018). Third, corrupt governments, especially in contexts of impunity, disregard civil rights, sometimes even humiliating civil liberties, and thus invade the public sphere and rob citizens of their rights. (Andersen, 2018). Fourth, when citizens are put in a corrupt system, they will feel that they are not treated equally, and by the law. For this reason, they will resort to bribery, corruption, or clientelism to gain political influence or gain their rights (Rose & Peiffer, 2015). This may undermine the spread of corruption and the rule of law in society (Rose-Ackerman & Palifka, 2016).

Finally, Chayes (2015) argues that corruption undermines the ability of governments to maintain security for all citizens. The corrupt political and administrative environment makes it possible for terrorist and religious fundamentalist groups to make the most of this space to achieve their goals. Thus, all of these factors reduce the public's confidence in the democratic system to solve society's problems. In other words, the spread of corruption in society initially makes elected governments unable to fulfill their assigned tasks, and this creates a kind of political culture in people who do not believe in the form of democratic governance and that distrust. Democracy also causes citizens to have little confidence in elected governments and political agents (You, 2005).

The third way that people's perceptions of corruption are influenced by political distrust comes from subjective and psychological factors. Researchers believe that democracy is likely to arise when political authorities can build and maintain public trust at the community level (Goodsell, 2006). Citizens lose confidence in democracy or democratically elected government when the country's political and public authorities are corrupted (Seligson, 2002). Surveys in some countries show that they lose trust in civil and public authorities only in countries where there is a high level of corruption (Anderson & Tverdova, 2003).

Thus, several scholars have examined the political system of countries and concluded that the type of policymaking of countries is one of the important factors that can influence political distrust by spreading or reducing corruption. Corruption, especially political corruption, can cause laws to benefit a certain segment of society, such as elites, politicians, or specific groups, so that others may incur costs. When this happens, ordinary citizens may conclude that the likelihood of problems being solved by the government in society is reduced (Caillier, 2010).

Corruption, therefore, is the cause of collapse because it puts government policies at odds with the interests of the majority and wastes national resources. Corruption also diminishes the effectiveness of governments in directing affairs, thereby exacerbating citizens' frustration with existing political processes and the country's future course. In this way, it weakens national trust in the state apparatus system and confronts it with a crisis of legitimacy and acceptance.

Hypothesis 1: Government performance (Ha), Disappointment about the future of the country (Hb), and democratic culture (Hc) mediate the relationship between corruption and political trust.

Corruption perception reduces trust in the government's ability to meet the needs of citizens and decreases public satisfaction with the government (Wang, 2016). World Bank research shows corruption corrupts public trust and social capital as gradual accumulation of seemingly small regulations slowly destroys political legitimacy (World Bank, 1997). When a citizen pays a bribe to get a public service or to avoid punishment for violating the law, there are two types of reactions that may occur depending on how you look at the bribe. Moreover, bribery may be seen as the cost of operating, just like those who want to cross a road or use a resort and willingly pay for services, tolls, and fees. Those who pay these costs may find such payments a legitimate deal and have no negative impact on their assessment of the legitimacy of the political system. Another group receiving such bribes may have a completely different reaction, calling it a lucrative and rent-seeking move. Renting is possible only because the person applying for such rent has both formal and informal government's permission to do so. Therefore, it can be predicted that the experience of these cases of corruption harms one's view of government (Rabiei & Normohammadi, 2016).

Thus, there appear to be two types of views on the political implications of the perception of corruption in society. The first view is a positive and optimistic one. Proponents of this perspective believe that corruption acts as a kind of "grease the wheels" in developing societies and that by removing many bureaucratic obstacles, citizens' support for the political system will increase (Merton & Merton, 1968). This group of scholars argues that corruption acts as a tool to connect different parts of society, which is desperately needed in developing societies (Leys, 1965). Huntington (2006), emphasizing the inefficiency of laws and institutions in developing countries, regarded corruption as a way of overcoming the inefficiency of laws and regulations, and referred to it as a positive thing. Becquart (1989) also argued that corruption in authoritarian countries protects certain areas of freedom on the one hand. Political corruption redistributes public resources in society through parallel tools available to previously disadvantaged social groups.

The other tradition in political science focuses mainly on the darker side of corruption and emphasizes the detrimental effects of corruption on political realms. In this regard, Etzioni-Halev (2013) and Johnston (1979) argue that corruption in the form of increased trust between the client and the customer in the community leads to a loss of confidence in the political system. This results in a decrease in citizens' support for the existing political principles and rules in the country. Other studies suggest that corruption is a major cause of political distrust among citizens, leading to a crisis of legitimacy and a decline in people's support for political systems (Booth & Seligson, 2009; Seligson, 2002).

Investigating eight Latin American countries, Booth and Seligson (2009) indicated that the experience of corruption undermines public confidence in the government, which in turn reduces public support for the political system. Similarly, using East Asia Barometer data, Chang and Chu (2006) found that political corruption harms people's perceptions of existing political rules in the country by destroying political trust and government legitimacy. Corruption diminishes the legitimacy and effectiveness of governments as far as it can put governments and political systems in a serious crisis of legitimacy and acceptance.

Smith (2010) suggested that perceived corruption is a key factor that negatively mediates the relationship between distributive justice norms and beliefs about social legitimacy and ultimately plays an important role in reducing the legitimacy of the social stratification system. Therefore, perceived corruption can have a major impact on the legitimacy and even viability of the existing economic system, stratification, and political systems as systems of justice. Mishler and Rose (2001) argued that when they saw a contradiction between government practice and political ideology, citizens are more influenced by government

performance and their understanding of government performance than by doctrines and ideologies. That exists. The higher the level of perception of corruption and the weaker the government performance seems to be, the more supportive of state ideology supporting political structures will be affected. [Hetherington \(1998\)](#) pointed out that political trust affects people's perceptions of the functioning of political institutions. When political confidence declines, people will have a negative assessment of political institutions as well as legitimate ideologies. According to [Inglehart \(1990\)](#), political distrust causes one to reject the existing political system as strongly as possible, and to support extreme right or left political structures.

Some of the main reasons for the negative impact of the perception of corruption on people's support for the prevailing ideology appear to be: Firstly, political and economic corruption creates cultural corruption so that government officials are not required to respond to their actions. In corrupt systems the laws that are formulated on paper are not guaranteed. So what is at stake is not the law, but the acquaintance with individuals and the bribe, that is, relationships take the place of rules. Therefore, people who do not have access to high levels of government cannot address their demands to the government elite ([Cerutti et al., 2013](#)). Second, in corrupt systems, legislators adopt policies and regulations that are not appropriate for politics and economics. These policies benefit only a few individuals who have close relationships with decision-makers or those who bribe government officials in favor of legislation that discriminates against other citizens ([Uslaner, 2008](#)). Third, corruption reduces the income of the poorest class of society, as it destroys private-sector job opportunities and also promotes inequality in society by limiting public sectors service costs such as access to health care and education ([Justesen & Bjørnskov, 2014](#)). Fourth, to succeed in creating a democratic society, countries need to create and nurture institutions that promote transparent policymaking. In corrupt systems, it is difficult to build healthy institutions with a proper structure. Corrupt government officials responsible for reform do not take measures to deprive them of the benefits of bribery and accountability. Corruption undermines the legitimacy of government positions and undermines the democratic process because people are not encouraged to participate ([Sandholtz & Koetzle, 2000](#)). This causes discontent among the middle class in society. Finally, corruption contributes to political instability as citizens tend to dismiss corrupt leaders and those who do not defend the public interests ([Farzanegan & Witthuhn, 2017](#)). Thus corruption appears to hurt citizens' satisfaction with the ruling political structures and undermine the legitimacy of the political system and ideological structures from the people's perspective ([Anderson & Tverdova, 2003](#)).

The ideology that governs Iraq seems to be political Islamism. Paragraph 1 of Article 2 of the Constitution of the Republic of Iraq (2005) states: "Islam is the official religion of the State". As a result, it is immediately stated in Part A of this Article: "law may be enacted that contradicts the established provisions of Islam". This is probably why Ayatollah Sistani and other religious authorities are easy to comment on and intervene in political matters. Even in many cases the leadership of political parties and groups in Iraq is the responsibility of the ayatollahs and religious clerics ([Sayej, 2018](#)). Therefore, given that most of the political structures in Iraq are owned by Islamist political groups or parties close to this ideology, the second research hypothesis is that:

Hypothesis 2: Perceptions of corruption indirectly diminish citizens' support for political Islam in Iraq by increasing political distrust.

METHOD

Data and methods

For the present study, the data collected through the Arab Barometer Wave V EN data provided during 2018–2019, conducted in collaboration with the universities of Michigan, Princeton, and other universities and research centers in the MENA region. The Arab Barometer Wave V EN data includes a survey of attitudinal and behavioral attitudes, especially in the political, cultural and social spheres, of citizens of Arab countries in wave V of 12 countries (Algeria, Egypt, Iraq, Jordan, Kuwait, Lebanon, Libya, Morocco, Palestine, Sudan, Tunisia, and Yemen).

Based on the data extracted from the latest Barometer Arab Data Wave, the present study surveyed 26,780 citizens of the 12 Arab countries mentioned above, including 24,600 Iraqi citizens.

In the present study, run in AMOS, SEM was used to analyze data and hypotheses. SEM predicts a set of multiple regression equations by specifying the structural model used in the statistical program in AMOS software and is, therefore, more accurate for testing hypotheses than the linear regression used in SPSS. Also, given that the research hypotheses address the indirect effects of perceptions of corruption on political distrust and support for political Islamism. So the SEM method can test the hypotheses better than other methods. However, before testing the structural model of the research, the research measurement models were examined. In this regard, in some measurement models, items with a factor load below 0.30 were omitted (Kline, 2015).

Measurement variables and descriptive statistics

Considering the theoretical framework and hypotheses, this paper uses six variables, the characteristics of which are obtained from the items in the Arab Barometer wave V. In this regard, the measured variables are:

1. *Corruption Perceptions*: Corruption perception refers to citizens' feelings about the abuse of the public sector and public institutions by the interests of individuals in society (Olken, 2009). Corruption perceptions were measured by responders' self-evaluations according to a 4-point Likert scale. In this regard, two items were used to measure perceptions of corruption: To what extent do you think that there is corruption within the national state agencies and institutions in your country? (1= To a large extent, 4= Not at all, Mean= 1.32; Corrected Item-Total Correlation= 0.41) [reversed]; (2) How widespread do you think corruption is in your local/municipal government? (1= Hardly anyone is involved, 4= Almost everyone is corrupt, Mean= 2.89; Corrected Item-Total Correlation= 0.41).

2. *Poor government performance*: One of the preconditions for development in any society is the good performance of its government and the efficiency of government institutions. However, sometimes citizens find the quality of service provided by government institutions inappropriate and inadequate. Five items were used to measure government performance in which the individual evaluates the current performance of the government in his country in the following ways: (1) The educational system (1= Completely satisfied, 4= Completely dissatisfied, Mean= 3.14; Corrected Item-Total Correlation= 0.44); (2) The healthcare system (1= Completely satisfied, 4= Completely dissatisfied, Mean= 2.99; Corrected Item-Total Correlation= 0.45); (3) Creating employment opportunities (1= Very good, 4= Very bad, Mean= 3.61; Corrected Item-Total Correlation= 0.35); (4) Narrowing the gap between rich and poor (1= Very good, 4= Very bad, Mean= 3.34; Corrected Item-Total Correlation= 0.34); and (5) Providing security and order (1= Very good, 4= Very bad, Mean= 2.46; Corrected Item-Total Correlation= 0.32).

3. *Wrong direction of the country*: For development, countries adopt different policies, and based on the type of policy, citizens can have positive or negative views on them. Three items were used to assess people's views on the correctness or inaccuracy of country policies. In this regard, the measured items are: (1) In general, do you think that things in Iraq are going in the right or wrong direction? (1= Going in the right direction, 3= Going in the wrong direction, Mean= 1.84; Corrected Item-Total Correlation= 0.27); (2) How would you evaluate the current economic situation in your country? (1= Very good, 4= Very bad, Mean= 3.11; Corrected Item-Total Correlation= 0.31); (3) What do you think will be the economic situation in your country during the next few years (2-3 years) compared to the current situation? (1= Much better, 5= Much worse, Mean= 2.77; Corrected Item-Total Correlation= 0.33).

4. *Support for democracy*: Some researchers believe that the perception of high levels of corruption in society can weaken democracy by undermining people's trust in their political regime, hence reducing people's support for democratic political systems (Seligson, 2006). In this regard, the degree of support for or disapproval of democracy was measured by 4 items on a 4-point Likert scale, including: (1) Under a democratic system, the country's economic performance is weak (1= I strongly agree, 4= I strongly disagree, Mean= 2.42; Corrected Item-Total Correlation= 0.52); (2) Democratic regimes are indecisive and full of problems (1= I strongly agree, 4= I strongly disagree, Mean= 2.42; Corrected Item-Total Correlation= 0.53); (3) Democratic systems are not effective at maintaining order and stability (1= I strongly agree, 4= I strongly disagree, Mean= 2.32; Corrected Item-Total Correlation= 0.55); and (4) Democratic systems may have problems, yet they are better than other systems (1= I strongly agree, 4= I strongly disagree, Mean= 2.01; Corrected Item-Total Correlation= 0.21) [reversed].

5. *Political distrust*: Political distrust refers to a relational attitude that reflects the perception of distrust of a political system as a whole or its components (Bertsou, 2019). In this study, political distrust is the lack of trust in political institutions that was measured via 4 items on a 4-point Likert scale. In this regard, respondents were asked how much they trust the following institutions: Government (Council of Ministers) (1= A great deal of trust, 4= No trust at all, Mean= 3.40; Corrected Item-Total Correlation= 0.63); (2) Courts and legal system (1= A great deal of trust, 4= No trust at all, Mean= 2.88; Corrected Item-Total Correlation= 0.50); (3) The elected council of representatives (the parliament) (1= A great deal of trust, 4= No trust at all, Mean= 3.59; Corrected Item-Total Correlation= 0.57); and (4) Local government (1= A great deal of trust, 4= No trust at all, Mean= 3.19; Corrected Item-Total Correlation= 0.57).

6. *Support for political Islam*: The term refers to a variety of forms of social and political activity claiming that public and political life should be guided by Islamic principles (Akbarzadeh, 2012). Individuals' acceptance or disapproval of political Islam was measured via 4 items on a 4-point Likert scale. In this regard, respondents were asked to what extent they agree or disagree with the following statements: Religious leaders should not interfere in voters' decisions in elections (1= I strongly agree, 4= I strongly disagree, Mean= 1.88; Corrected Item-Total Correlation= 0.22); (2) Your country is better off if religious people hold public positions in the state (1= I strongly agree, 4= I strongly disagree, Mean= 2.89; Corrected Item-Total Correlation= 0.34) [reversed]; (3) Religious practice is a private matter and should be separated from socio-economic life (1= I strongly agree, 4= I strongly disagree, Mean= 1.87; Corrected Item-Total Correlation= 0.28); and (4) Today, religious leaders are as likely to be corrupt as non-religious leaders (1= I strongly agree, 4= I strongly disagree, Mean= 1.97; Corrected Item-Total Correlation= 0.26).

Table 1. Means, standard deviations, and correlations between the variables

	1	2	3	4	5	6	7	8	9	10
1. Age	1.00									
2. Gender (female)	.07	1.00								
3. Education	-.17	-.12	1.00							
4. Income situation	-.07	-.06	.23	1.00						
5. Corruption Perceptions	-.02	-.04	.10	.03	1.00					
6. Poor government performance	-.03	-.04	.16	.06	.37	1.00				
7. wrong direction of country	0.05	-0.05	0.10	0.02	0.30	.40	1.00			
8. Democracy	-0.00	-0.06	0.06	0.05	-0.09	-0.07	-0.06	1.00		
9. Political distrust	0.00	0.01	0.12	0.11	0.40	0.46	0.42	-0.15	1.00	
10. Political Islam	-0.02	0.08	-0.15	-0.00	-0.13	-0.13	-0.09	0.03	-0.08	1.00
Mean	34.8	1.4	3.4	2.5	3.2	3.1	2.5	2.5	3.2	1.9
Standard deviation	13.8	0.5	1.5	0.9	0.5	0.5	0.5	0.6	0.6	0.6

Notes: bold numbers indicate a significant relationship between scores ($p < 0.05$)

Table 1 provides a breakdown of the preliminary correlations between the study variables. According to the results, except for age and gender, other variables had a significant relationship with political distrust. While democracy has had a negative relationship with political distrust, the relationship between education level, income status, corruption perceptions, poor government performance, and a negative impression of the country's future with positive political distrust was positive. Also shown is the women were more inclined to political Islamism than men. But the relationship between education levels, perceptions of corruption, poor government performance, negative perceptions of the country's future, and political distrust have been negatively correlated with political Islamism.

RESULTS

Considering research theories, on the one hand, corruption perception is expected to directly affect citizens' assessments of government performance, the direction of the country, and support for democracy, and on the other hand, existing theories show that the perception of corruption can, indirectly, reduce the political trust of citizens and lead them to the ideology of political Islamism. In this regard, the research hypotheses were tested by Amos graphics, the results of which are reported below.

Figure 1 illustrates the empirical model of the research in the form of structural equation modeling. Regarding the goodness of fit and coefficients of the model, it should be noted that the research model fits the model well and the data collected support the theoretical framework of the research: (Model goodness of fit: CMIN / DF = 3.72, RMSEA = 0.033; PCLOSE = 1.00, CFI = 0.938, GFI = 0.972, AGFI = 0.965, TLI = 0.929, IFI = 0.939, PNFI = 0.799). Also in this figure, nonstandard path coefficients and standard error represent the strength of the relationships between the independent and dependent variables in the model. Also, the above diagram shows that all standard factor loadings are above 0.30 and there is no need to delete any of the observable variables (Kline, 2015).

Figure 1. Specified SEM shows unstandardized path coefficients with standard errors in parentheses. Note: This theoretical model was also bootstrapped based on the standard errors with 1,000 iterations and with a 95 percent confidence interval

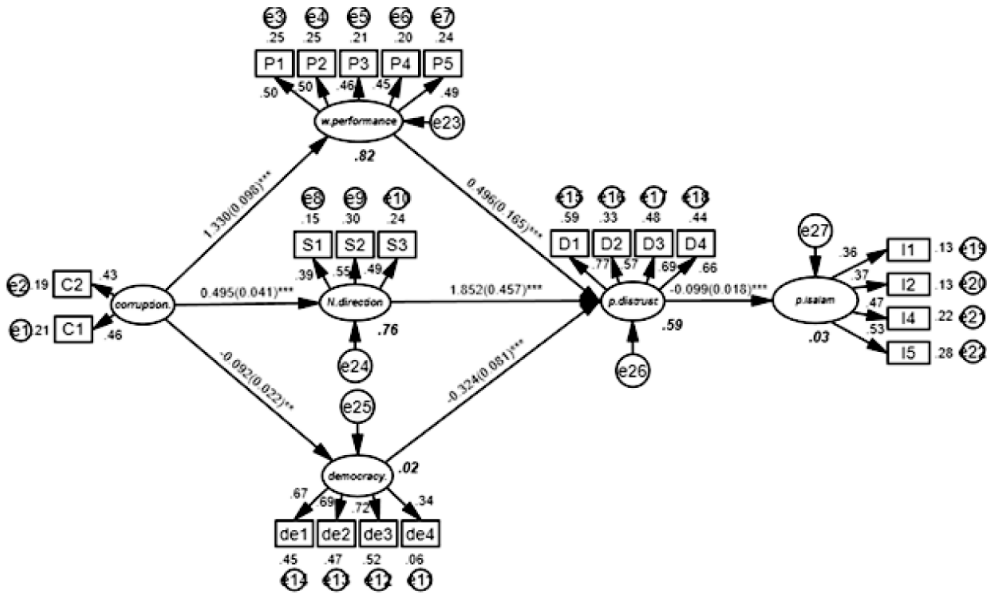

Table 2. Direct and indirect standardized effects on dependent variables

	Pe	Ne	De	Di	Is
		Direct		Direct	Direct
				Indirect	Indirect
Co	0.903***	0.870***	-0.136**	0.714***	-0.130***
Pe				0.325***	-0.059***
Ne				0.469***	-0.085***
De				-0.097***	0.018**
Di					-0.182***
R ²	0.82	0.76	0.02	0.59	0.03

Notes: *p < 0.05 **p < 0.01 ***p < 0.001. In this study: Co= Corruption Perceptions; Pe= poor government performance; Ne= wrong direction of the country; De= Democracy; Di= political distrust; and Is= Political Islam.

Table 3 examines the direct and indirect effects of the research variables. Results of SEM show that perception of corruption had a positive and significant effect on poor government performance ($\beta = 0.90, p < 0.01$) and negative perception of country path ($\beta = -0.13, p < 0.01$). The effect of public perception of corruption on the tendency for democracy was significant among the citizens ($\beta = 0.90, p < 0.01$) and reduced the democratic tendency among them. Also, the effect of political distrust on support for political Islamism is negative and significant and reduces the tendency for political Islamism in citizens ($\beta = -0.18, p < 0.01$).

As shown in the table above, the indirect effects of the variables were also tested in this study, and the Sobel test was used to determine the significance of the standard coefficients. The standard coefficients of the study indicate that citizens 'general perception

of corruption has a significant indirect effect on political mistrust and increases individuals' political mistrust ($\beta = 0.71$, Sobel's $z = 3.23$, $p < 0.01$). On the other hand, the indirect effect of public perceptions of corruption on citizens' support for political Islam is also significant, and the results show that public perception of corruption reduces people's support for political Islam ($\beta = 0.71$, $p < 0.01$). The results also show that the negative perception of the path of the country indirectly and significantly reduces the support of people for political Islamism ($\beta = 0.08$, Sobel's $z = -3.26$, $p < 0.01$). Poor performance by the government is another variable that has a significant and negative effect on people's support for political Islamism ($\beta = 0.05$, Sobel's $z = -2.63$, $p < 0.01$). Finally, the indirect impact of democracy on support for political Islamism is significant and positive. There seems to be no conflict between political Islamism and democracy in Iraq ($\beta = 0.02$, Sobel's $z = -3.23$, $p < 0.01$).

CONCLUSION

This article empirically assesses the impact of the perception of corruption on the level of political trust and its effects on the political ideology of Islamism in Iraq. In the first section, the reasons for the impact of the perception of corruption on political distrust and the spread of Islamism are outlined. In this regard, research theories in the first part of the study showed that perceptions of corruption may indirectly affect political distrust and political Islamization in societies. In the second part of the research, the hypotheses obtained from the research theories were tested through SEM.

The results showed that on the one hand, citizens' perceptions of corruption increase people's negative appraisal of government performance, the direction of the country, and increased demand democracy in society. Moreover, these three variables influence political distrust. In other words, government performance and direction of the country increase political distrust, but the demand for democracy decreases political distrust in society. This finding is also consistent with many research theories (La Porta et al., 2000; Seligson, 2006; Chayes, 2015; Caillier, 2010), suggesting that citizens' perceptions of corruption can indirectly strengthen political distrust in society.

Another result of this study is the indirect impact of the perception of corruption on the spread of Islamism in society. The results, consistent with Booth and Seligson's (2009) findings, showed that corruption perceptions through increasing political distrust can affect the decline of political legitimacy in society. Although there are various interpretations of the political ideology in Iraq, as noted in the theoretical section, some of the constitutional materials as well as the political and cultural realities in Iraq show that the ideology of political Islamism occupies a high position in the political system in power. For this reason, corruption perceptions indirectly diminish political Islamism by increasing distrust in political institutions. In other words, as Anderson and Tverdova (2003) argued, corruption perceptions can hurt citizens' satisfaction with existing political structures and reduce the legitimacy of the political system and ideological structures from the public's perspective.

It is therefore clear that, given the strong ideology of Shiite and Sunni Islamism in Iraq, such cultural and political structures will be challenged by citizens through the perception of corruption. In other words, as the results show, people's corruption perceptions are skeptical of government capabilities, negative and hopeless about the economic future of the country, and skeptical of democratic political culture, which is one of the essential requirements of political trust in societies. This causes political distrust in society to increase. Increasing political distrust of political institutions in societies where the ideology of political Islamism is heavily influenced by their political and cultural structures makes people's tendency for ideology be questioned and diminished.

The research results are also consistent with the theories of Etzioni-Halev (2013) and Johnston (1979) that the corruption perceptions act as barriers to political development, political trust, and the legitimacy of the political system. While some scholars, such as Huntington (2006) and Becquart (1989), cited corruption as a positive thing because of the inefficiencies of the structures in the political system of developing countries, The findings of this study, consistent with post-1990s theories, show that corruption perceptions, at least sociologically, negatively affect citizens' attitudes toward the cohesive and correlating factors of the political system, Thus, by undermining the legitimacy of institutions and political ideology in society, it provides the stage for bipolar or multipolar gaps in society. The gaps that have been made in recent years in Iraq in recent years have created a wave of political tensions and conflicts at the community level to create a bureaucratic and pragmatic government that can deal with systemic corruption.

This study provides insights into the relationship between government performance and corruption perceptions to explain political distrust and its impact on perceptions of political ideology. Although the current study focuses on Iraqi society, it is possible to conduct replication studies in other countries, especially in the Middle East, to measure the key variables discussed in this study. Since Middle Eastern countries have ideological structures and high levels of corruption compared to democratic countries, the findings of this study may be generalized to these countries as well. Future research should examine whether the weakening of political Islam as a state ideology leads to the rise of democracy in the country. And whether the results of this study can be generalized to other countries in the Middle East that have ideological structures?

As the research findings suggest, it seems that as the statistics of most international organizations, especially Transparency International (TI), show the level of high inefficiency and corruption in the Arab countries of the Middle East. Contrary to the theory of "grease the wheels", the administration of high levels of corruption by citizens in these countries has led them to seek justice, poverty and the lack of economic and political development of their countries in the inadequacy of leaders and institutions. Therefore, their trust in the ruling political institutions should be reduced and they should seek alternatives to the established political regimes. Moreover, since political Islamism has a high influence in the historical, social and political contexts of Middle Eastern societies, religious fundamentalism is presented as a strong alternative to the ruling regimes in the countries of the region. People are increasingly turning to political Islamism. However, to further generalize these results, it is suggested that other researchers study this issue in other countries, including the countries of the Mena region, to test its accuracy in these areas.

REFERENCES

- Abdullah, S. M. (2017). *Clientelism, Rent-Seeking, and Protection: A Study of Corruption in Iraq after 2003*, Ph.D. Thesis, Newcastle University.
- Akbarzadeh, S. (2012). *Routledge Handbook of Political Islam*. London and New York: Routledge. <https://doi.org/10.4324/9780203154144>
- Alesina, A. & Angeletos, G. M. (2005). Corruption, Inequality, and Fairness. *Journal of Monetary Economics*, 52(7), 1227–1244. <https://doi.org/10.1016/j.jmoneco.2005.05.003>
- Andersen, M. K. (2018). Why Corruption Matters in Human Rights. *Journal of Human Rights Practice*, 10(1), 179–190. <https://doi.org/10.1093/jhuman/huy004>
- Anderson, C. J. & Tverdova, Y. V. (2003). Corruption, Political Allegiances, and Attitudes Toward Government in Contemporary Democracies. *American Journal of Political Science*, 47(1), 91–109. <https://doi.org/10.1111/1540-5907.00007>

- Arab Barometer. (2019). *Arab-Barometer: Public Opinion Survey Conducted in Algeria, Egypt, Iraq, Jordan, Kuwait, Lebanon, Libya, Morocco, Palestine, Sudan, Tunisia, Yemen, 2018-2019*. Ann Arbor, Mich: Inter-university Consortium for Political and Social Research.
- Ashforth, B. E., Gioia, D. A., Robinson, S. L. & Treviño, L. K. (2008). Re-Viewing Organizational Corruption. *Academy of Management Review*, 33(3), 670–684.
<https://doi.org/10.5465/amr.2008.32465714>
- Barkemeyer, R., Preuss, L. & Ohana, M. (2018). Developing Country Firms and the Challenge of Corruption. *Academy of Management Proceedings*, 2018(1), 12765.
<https://doi.org/10.1016/j.jbusres.2018.04.025>
- Barr, A. & Serra, D. (2010). Corruption and Culture: An Experimental Analysis. *Journal of Public Economics*, 94(11–12), 862–869. <https://doi.org/10.1016/j.jpubeco.2010.07.006>
- Becquart, J. (1989). Paradoxes of Political Corruption: A French View, In A.J. Heidenheimer, M. Johnston and V.T. LeVine (Eds.), *Political Corruption*, 191–210. New Brunswick and Oxford: Transaction Publishers.
- Bertsou, E. (2019). Rethinking Political Distrust. *European Political Science Review*, 11(2), 213–230. <https://doi.org/10.1017/S1755773919000080>
- Booth, J. A. & Seligson, M. A. (2009). *The legitimacy puzzle in Latin America: Political support and democracy in eight nations*. New York: Cambridge University Press.
<https://doi.org/10.1017/CBO9780511818431>
- Budsaratragoon, P. & Jitmaneroj, B. (2020). A Critique of the Corruption Perceptions Index: An Interdisciplinary Approach. *Socio-Economic Planning Sciences*, 70, 100768.
<https://doi.org/10.1016/j.seps.2019.100768>
- Caillier, J. (2010). Citizen Trust, Political Corruption, and Voting Behavior: Connecting the Dots. *Politics and Policy*, 38(5), 1015–1035. <https://doi.org/10.1111/j.1747-1346.2010.00267.x>
- Cerutti, P. O., Tacconi, L., Lescuyer, G. & Nasi, R. (2013). Cameroon's Hidden Harvest: Commercial Chainsaw Logging, Corruption, and Livelihoods. *Society and Natural Resources*, 26(5), 539–553. <https://doi.org/10.1080/08941920.2012.714846>
- Chang, E. C. & Chu, Y. H. (2006). Corruption and Trust: Exceptionalism in Asian Democracies? *The Journal of Politics*, 68(2), 259–271. <https://doi.org/10.1111/j.1468-2508.2006.00404.x>
- Chayes, S. (2015). *Thieves of state: Why Corruption Threatens Global Security*. New York: W.W. Norton and Company.
- Chen, Y., Yaşar, M. & Rejesus, R. M. (2007). Factors Influencing the Incidence of Bribery Payouts by Firms: A Cross-Country Analysis. *Journal of Business Ethics*, 77(2), 231–244.
<https://doi.org/10.1007/s10551-006-9346-4>
- Choi, E. (2014). Political Corruption, Trust, and Citizen Evaluations of Democracy: A Cross-National Analysis. *Asian International Studies Review*, 15(2), 1–23.
<https://doi.org/10.16934/isr.15.2.201412.1>
- Coleman, J. (1990). *Foundations of Social Theory*. Cambridge: Harvard University Press.
- Constitution of the Republic of Iraq. (2005). *Constitution of the Republic of Iraq*. Retrieved 24 December 2019, from <https://www.refworld.org/docid/454f50804.html>
- Desta, Y. (2019). Manifestations and Causes of Civil Service Corruption in the Developing Countries. *Journal of Public Administration and Governance*, 9(3), 23–35.
<https://doi.org/10.5296/jpag.v9i3.14930>
- Dincer, O. C. & Gunalp, B. (2012). Corruption and Income Inequality in the United States. *Contemporary Economic Policy*, 30(2), 283–292.
<https://doi.org/10.1111/j.1465-7287.2011.00262.x>

- Doorenspleet, R. (2019). Democracy and Corruption. In *Rethinking the Value of Democracy* (pp. 165–200). Palgrave Macmillan, Cham. https://doi.org/10.1007/978-3-319-91656-9_5
- Drapalova, E. (2019). *Corruption and the Crisis of Democracy*. Berlin: Transparency International Anti-Corruption Helpdesk.
- Etzioni-Halevy, E. (2013). *Bureaucracy and Democracy*. Routledge Library Editions: Political Science. <https://doi.org/10.4324/9780203707890>
- Farzanegan, M. R. & Witthuhn, S. (2017). Corruption and Political Stability: Does the Youth Bulge Matter? *European Journal of Political Economy*, 49, 47–70. <https://ssrn.com/abstract=2791977>
- Fisman, R. & Miguel, E. (2008). *Economic Gangsters: Corruption, Violence, and Poverty of Nations*. Princeton, N.J.: Princeton University Press.
- Goldberg, F. (2018). Corruption and Lobbying: Conceptual Differentiation and Gray Areas. *Crime, Law, and Social Change*, 70(2), 197–215. <https://doi.org/10.1007/s10611-017-9727-x>
- Goodsell, C. T. (2006). A New Vision for Public Administration. *Public Administration Review*, 66(4), 623–635. <https://doi.org/10.1111/j.1540-6210.2006.00622.x>
- Granovetter, M. (2007). 'The Social Construction of Corruption'. In V. Nee and R. Swedberg (Ed). *On Capitalism* (pp. 152–72), Stanford: Stanford University Press.
- Gray, C. W. & Kaufman, D. (1998). Corruption and Development. *Finance and Development*, 35(1), 7–10.
- Hetherington, M. J. (1998). The Political Relevance of Political Trust. *American Political Science Review*, 92(4), 791–808. <https://doi.org/10.2307/2586304>
- Hudson, J. (2006). Institutional Trust and Subjective Well-Being Across the EU. *Kyklos*, 59(1), 43–62. <https://doi.org/10.1111/j.1467-6435.2006.00319.x>
- Huntington, S. P. (2006). *Political Order in Changing Societies*. New Haven: Yale University Press.
- Inglehart, R. (1990). *Culture Shift in Advanced Industrial Society*. Princeton: Princeton University Press. <https://doi.org/10.1515/9780691186740>
- Jancsics, D. (2014). Interdisciplinary Perspectives on Corruption. *Sociology Compass*, 8(4), 358–372. <https://doi.org/10.1111/soc4.12146>
- Jaskiewicz, P., Uhlenbruck, K., Balkin, D. B. & Reay, T. (2013). Is Nepotism Good or Bad? Types of Nepotism and Implications for Knowledge Management. *Family Business Review*, 26(2), 121–139. <https://doi.org/10.1177/0894486512470841>
- Johnston, M. (1979). Patrons and Clients, Jobs, and Machines: A Case Study of the Uses of Patronage. *American Political Science Review*, 73(2), 385–398. <https://doi.org/10.2307/1954886>
- Justesen, M. K. & Bjørnskov, C. (2014). Exploiting the Poor: Bureaucratic Corruption and Poverty in Africa. *World Development*, 58, 106–115. <https://doi.org/10.1016/j.worlddev.2014.01.002>
- Kish-Gephart, J. J., Harrison, D. A. & Treviño, L. K. (2010). Bad Apples, Bad Cases, and Bad Barrels: Meta-Analytic Evidence about Sources of Unethical Decisions at Work. *Journal of Applied Psychology*, 95(1), 1–31. <https://doi.org/10.1037/a0017103>
- Kline, R. B. (2015). *Principles and Practice of Structural Equation Modeling*. New York: Guilford publications.

- Kuokstis, V. (2012). Trust and Taxes: Estonian and Lithuanian Fiscal Performance During the Crisis. In *APSA 2012 Annual Meeting Paper*.
- La Porta, R., Lopez-de-Silanes, F., Shleifer, A. & Vishny, R. (2000). Investor Protection and Corporate Governance. *Journal of Financial Economics*, 58(1-2), 3–27.
[https://doi.org/10.1016/S0304-405X\(00\)00065-9](https://doi.org/10.1016/S0304-405X(00)00065-9)
- Ledeneva, A. (2009). Corruption in Postcommunist Societies in Europe: A Re-examination. *Perspectives on European Politics and Society*, 10(1), 69–86.
<https://doi.org/10.1080/15705850802700017>
- Lee, A. R. (1994). Economics vs. Values in Political Trust in Korea. *Studies in Comparative International Development*, 29(4), 25–40. <https://doi.org/10.1007/BF02802946>
- Leys, C. (1965). What is the Problem about Corruption, *The Journal of Modern African Studies*, 3(2), 215–230. <https://doi.org/10.1017/S0022278X00023636>
- Mauro, P. (1995). Corruption and Growth. *The Quarterly Journal of Economics*, 110(3), 681–712.
<https://doi.org/10.2307/2946696>
- Merton, R. K. & Merton, R. C. (1968). *Social theory and Social Structure*. New York: Simon and Schuster.
- Mishler, W. & Rose, R. (2001). What are the Origins of Political Trust? Testing Institutional and Cultural Theories in Post-communist Societies. *Comparative Political Studies*, 34(1), 30–62. <https://doi.org/10.1177%2F0010414001034001002>
- Moreno, A. (2002). Corruption and Democracy: A Cultural Assessment. *Comparative Sociology*, 1(3-4), 495–507. <https://doi.org/10.1163/156913302100418556>
- Morris, S. D. & Klesner, J. L. (2010). Corruption and Trust: Theoretical Considerations and Evidence from Mexico. *Comparative Political Studies*, 43(10), 1258–1285.
<https://doi.org/10.1177/0010414010369072>
- Nelson, M. A. (2012). Corruption and the Size of Local Governments: Are they Related? *International Center for Public Policy Working Paper Series*, at AYSPS, GSU paper1210, International Center for Public Policy, Andrew Young School of Policy Studies, Georgia State University.
- Nuijten, M. & Anders, G. (2007). *Corruption and the secret of Law: A Legal Anthropological Perspective*. Aldershot: Ashgate Publishing.
- Olken, B. A. (2009). Corruption Perceptions vs. Corruption Reality. *Journal of Public Economics*, 93(7-8), 950–964. <https://doi.org/10.1016/j.jpubeco.2009.03.001>
- Posada Carbó, E. & Walter, L. (1996). *Political Corruption in Europe and Latin America*. New York: St. Martin's Press.
- Putnam, R. D. (2000). Bowling Alone: America's Declining Social Capital. In *Culture and Politics* (pp. 223–234). New York: Palgrave Macmillan.
https://doi.org/10.1007/978-1-349-62397-6_12
- Rabiei, H. & Normohammadi, M. (2016). The Explanation of the Relationship between Smuggling and State Efficiency and its Role in Political Legitimacy. *Strategic Research on Social Problems in Iran University of Isfahan*, 5(1), 15–28.
<https://dx.doi.org/10.22108/ssoss.2016.20947>
- Rose, R. & Peiffer, C. (2015). Choices in Surveys. In: *Paying Bribes for Public Services: A Global Guide to Grass-Roots Corruption*. Basingstoke: Palgrave Macmillan.
<https://doi.org/10.1057/9781137509673>

- Rose-Ackerman, S. & Palifka, B. J. (2016). *Corruption and Government: Causes, Consequences, and Reform*. New York: Cambridge University Press.
<https://doi.org/10.1017/CBO9781139962933>
- Rothstein, B. & Eek, D. (2009). Political Corruption and Social Trust: An Experimental Approach. *Rationality and Society*, 21(1), 81–112. <https://doi.org/10.1177/1043463108099349>
- Sandholtz, W. & Koetzle, W. (2000). Accounting for Corruption: Economic Structure, Democracy, and Trade. *International Studies Quarterly*, 44(1), 31–50.
<https://doi.org/10.1111/0020-8833.00147>
- Sawaan, H. K. (2012). The Corruption of Political Elites in Iraq—an Economic Analysis. *Contemporary Arab Affairs*, 5(1), 107–127. <https://doi.org/10.1080/17550912.2012.649586>
- Sayej, C. M. (2018). *Patriotic Ayatollahs: Nationalism in Post-Saddam Iraq*. Ithaca: Cornell University Press. <https://doi.org/10.7591/cornell/9781501715211.001.0001>
- Seligson, M. A. (2002). The Impact of Corruption on Regime Legitimacy: A Comparative Study of Four Latin American Countries. *The Journal of Politics*, 64(2), 408–433.
<https://doi.org/10.1111/1468-2508.00132>
- Seligson, M. A. (2006). The measurement and Impact of Corruption Victimization: Survey Evidence from Latin America. *World Development*, 34(2), 381–404.
<https://doi.org/10.1016/j.worlddev.2005.03.012>
- Smith, M. L. (2010). Perceived Corruption, Distributive Justice, and the Legitimacy of the System of Social Stratification in the Czech Republic. *Communist and Post-Communist Studies*, 43(4), 439–451. <https://doi.org/10.1016/j.postcomstud.2010.10.005>
- Terziev, V. & Petkov, M. (2017). Corruption and National Security. *SSRN Electronic Journal*.
<https://dx.doi.org/10.2139/ssrn.3142894>
- Transparency International (2019). *Corruption Perceptions Index 2018: Sources of Information*. Transparency International. Retrieved 29 December 2019 from
<https://www.transparency.org/cpi2018> on 29 December 2019
- Uslaner, E. M. (2005). Trust and Corruption. *The New Institutional Economics of Corruption*. eds. Johann Graff Lambsdorf, Markus Taube, and Matthias Schramm. New York: Routledge.
- Uslaner, E. M. (2008). *Corruption, Inequality, and the Rule of Law: The Bulging Pocket Makes Easy Life*. New York: Cambridge University Press.
<https://doi.org/10.1017/CBO9780511510410>
- Wang, C. H. (2016). Government Performance, Corruption, and Political Trust in East Asia. *Social Science Quarterly*, 97(2), 211–231. <https://doi.org/10.1111/ssqu.12223>
- World Bank. (1997). *World Development Report 1997*, Washington, DC: World Bank Group.
- You, J. S. (2005). *Corruption and Inequality as Correlates of Social Trust: Fairness matters more than similarity*. Working paper 29, Hauser Center for Nonprofit Organizations, Harvard University.
- Ziblatt, D. (2009). Shaping Democratic Practice and the Causes of Electoral Fraud: The Case of Nineteenth-Century Germany. *American Political Science Review*, 103(1), 1–21.
<https://doi.org/10.1017/S0003055409090042>

BIOGRAPHICAL NOTES

Mahmoud Reza Rahbarqazi is an assistant professor of political science at the University of Isfahan (Iran). He has been doing some research in the field of political science at the university for six years. He holds a PhD in Political Science, the field of Political Sociology. His main research interests are in the political protests in the Middle East and Iran. He has recently published some studies in political science and sociology journals including: "Participation in Political Protest: Tracing Direct and Indirect Effects of News Usage and Social Interaction" (Observatorio, 2019), "Political Attitudes of Arab Citizens in North Africa" (Politologija, 2019), "Social Media, Political Discussion, and Political Protest: A Case Study of the 2018 Political Protests in Iran" (KOME, 2019).

Reza Mahmoud Oghli is an assistant professor of political science at Mohaghegh Ardabili University (Iran). He has been researching political science at Mohaghegh Ardabili University for 5 years. He holds a PhD in Political Science, the field of Political Sociology. His main research interests are political participation and political protests, especially the effect of the new media on the political protests of non-democratic societies. He has recently published some pieces of research in political science and sociology journals including: "Religion and political engagement" (Cogent Social Sciences, 2017), "Investigation effects of social networks on political activism in students University of Isfahan" (Quarterly Journal of Socio - Cultural Development Studies, 2016).