

Banco Central de Chile
Documentos de Trabajo

Central Bank of Chile
Working Papers

N° 254

Diciembre 2003

**THE MONETARY TRANSMISSION MECHANISM IN
CHILE: A MEDIUM-SIZED MACROECONOMETRIC
MODEL**

Carlos García

Pablo García

Igal Magendzo

Jorge Restrepo

La serie de Documentos de Trabajo en versión PDF puede obtenerse gratis en la dirección electrónica: <http://www.bcentral.cl/esp/estpub/estudios/dtbc>. Existe la posibilidad de solicitar una copia impresa con un costo de \$500 si es dentro de Chile y US\$12 si es para fuera de Chile. Las solicitudes se pueden hacer por fax: (56-2) 6702231 o a través de correo electrónico: bcch@bcentral.cl.

Working Papers in PDF format can be downloaded free of charge from: <http://www.bcentral.cl/eng/stdpub/studies/workingpaper>. Printed versions can be ordered individually for US\$12 per copy (for orders inside Chile the charge is Ch\$500.) Orders can be placed by fax: (56-2) 6702231 or e-mail: bcch@bcentral.cl.



BANCO CENTRAL DE CHILE

CENTRAL BANK OF CHILE

La serie Documentos de Trabajo es una publicación del Banco Central de Chile que divulga los trabajos de investigación económica realizados por profesionales de esta institución o encargados por ella a terceros. El objetivo de la serie es aportar al debate de tópicos relevantes y presentar nuevos enfoques en el análisis de los mismos. La difusión de los Documentos de Trabajo sólo intenta facilitar el intercambio de ideas y dar a conocer investigaciones, con carácter preliminar, para su discusión y comentarios.

La publicación de los Documentos de Trabajo no está sujeta a la aprobación previa de los miembros del Consejo del Banco Central de Chile. Tanto el contenido de los Documentos de Trabajo, como también los análisis y conclusiones que de ellos se deriven, son de exclusiva responsabilidad de su o sus autores y no reflejan necesariamente la opinión del Banco Central de Chile o de sus Consejeros.

The Working Papers series of the Central Bank of Chile disseminates economic research conducted by Central Bank staff or third parties under the sponsorship of the Bank. The purpose of the series is to contribute to the discussion of relevant issues and develop new analytical or empirical approaches in their analyses. The only aim of the Working Papers is to disseminate preliminary research for its discussion and comments.

Publication of Working Papers is not subject to previous approval by the members of the Board of the Central Bank. The views and conclusions presented in the papers are exclusively those of the author(s) and do not necessarily reflect the position of the Central Bank of Chile or of the Board members.

Documentos de Trabajo del Banco Central de Chile
Working Papers of the Central Bank of Chile
Huérfanos 1175, primer piso.
Teléfono: (56-2) 6702475; Fax: (56-2) 6702231

THE MONETARY TRANSMISSION MECHANISM IN CHILE: A MEDIUM-SIZED MACROECONOMETRIC MODEL

Carlos García
Gerencia de Análisis
Macroeconómico
Banco Central de Chile

Pablo García
Gerencia de Análisis
Macroeconómico
Banco Central de Chile

Igal Magendzo
Gerencia de Análisis
Macroeconómico
Banco Central de Chile

Jorge Restrepo
Gerencia de Análisis
Macroeconómico
Banco Central de Chile

Resumen

En este artículo se propone y estima un modelo macroeconómico para la economía chilena. El modelo está diseñado como herramienta para proyectar la inflación a corto y mediano plazo, e identificar precisamente el mecanismo de transmisión que sigue la política monetaria en Chile. El modelo especifica la dinámica de corto plazo, así como las condiciones de equilibrio de largo plazo. Se usan técnicas de cointegración y corrección de errores para estimar los parámetros correspondientes, y se calibran algunas relaciones. Incluye además los principales componentes de la demanda agregada y de las cuentas externas, un bloque de oferta que se sustenta en una función estándar de producción, una especificación para los precios de activos, y un bloque de salario/margen/precio y mercado laboral. Se toma en cuenta la interdependencia entre corto y largo plazo de cada uno de estos factores para entregar un equilibrio dinámico macroeconómico prospectivo. Los precios relativos clave de estado estacionario, tales como la tasa de interés real de largo plazo, el tipo de cambio, y el premio por riesgo soberano se determinan en forma exógena. El modelo se usa para explorar y cuantificar los efectos de la política monetaria sobre la inflación, y la forma en que la primera se transmite a la segunda. Los resultados de este trabajo se comparan con los de otros modelos más simples pero menos informativos, tales como los VAR y un modelo macroeconómico a menor escala, basado en curvas de Phillips. Por último se analiza la respuesta de algunas variables macroeconómicas fundamentales frente a una serie de shocks permanentes.

Abstract

This paper proposes and estimates a macroeconomic model of the Chilean economy. The model is designed as a short- and medium-term inflation-forecasting tool, which precisely identifies the transmission mechanism followed by monetary policy in Chile. The model specifies short-run dynamics as well as long-run equilibrium conditions. Cointegration and error correction techniques are used to estimate the relevant parameters, while some relations are calibrated. The model includes the main components of aggregate demand and external accounts, a supply-side block that relies on a standard production function, a specification for asset prices, and a wage/markup/price and labor market block. The short- and long run interdependence among each of these factors is taken into account to yield a forward-looking macroeconomic dynamic equilibrium. The key steady-state relative prices, such as the long-run real interest rate, the real exchange rate, and the sovereign risk premium, are endogenously determined. The model is used to explore and quantify the effects of monetary policy on inflation and how monetary policy is transmitted to inflation. The results obtained here are compared to the results of other simpler but less informative models, such as VAR and a smaller scale macroeconomic model, based on Phillips curves. The paper analyzes the response of some key macroeconomic variables to a number of permanent shocks.

We are extremely grateful to William Baeza, Dolly Bellani, Gabriela Contreras, Felipe Liendo, and Leonardo Luna for outstanding assistance in the estimation and implementation of the different blocks of the model.
E-mail: imagendz@bcentral.cl.

INTRODUCTION

The objective in building and specifying macroeconomic models is to reflect the main characteristics of an economy in a stylized way. This article describes a macroeconometric model for the Chilean economy. The aim of the model is to forecast the main macroeconomic variables, along with policy exercises and simulations. The different model equations describe both short-term movements within the economy and the long-term equilibrium. It is in this latter sense that the model can be described as structural. The main area interest in this kind of model involves the different dynamics of the variables, which can provide insight, for example, on the lags and magnitude of monetary policy transmission mechanisms. Their estimation is no substitute, however, for ensuring a medium-term equilibrium point toward which the economy must necessarily converge. We therefore use cointegration and error correction techniques for estimating the parameters. We also calibrate relations where necessary.

The model includes the main components of aggregate demand and external accounts. It also incorporates an aggregate supply block based on a standard production function, an equation for asset prices, and a wage, labor, margin, and price block. The key relative prices in the steady state, such as the real long-term interest rate, the real exchange rate, and the sovereign premium, are determined endogenously. We use the model to analyze and quantify the influence of monetary policy over inflation and the transmission mechanisms. The results are compared with those from a small macroeconomic model and several vector autoregressive (VAR) models, based on Phillips curves. Although these models are simpler and easier to manage, they provide less information.

This model was developed out of a need to answer more questions than a simpler gap model can address, by increasing the number of endogenous variables and dealing with the different transmission mechanisms in greater detail. It also reflects the need for a wider variety of possibilities for analyzing economic policy, together with the fact that the simulation process is dynamic in itself, so that models are constantly being revised.

The next section highlights a series of stylized facts about the Chilean economy that must necessarily be reflected in the model. We then describe the model, in terms of both its steady state and behavioral equations. The concluding section explores the empirical properties of the model using impulse response exercises.

1. SOME STYLIZED FACTS ABOUT THE CHILEAN ECONOMY

The stylized facts presented in this section allow us to define some of the characteristics that a macroeconometric model must contain in order to simulate the Chilean economy.

1.1 Stable Factoral Distribution of Income

The labor factor's share (α_N) of nominal gross domestic product (GDP) fluctuated around 53 percent during the period under analysis (1990-2001). We estimated it by dividing the wage bill by nominal GDP (YN), with different weights for wage-earning employees and self-employed workers.¹

1. When calculating the wage bill, different types of workers must be weighted, according to whether they are employees (NW) or self-employed (NSE). The first contribute to social security,

Labor's stable share of GDP over time, as figure 1 indicates, suggests that long-term employment to real wages and employment to output elasticities equal one. Because real wages tended to rise throughout this period, labor's stable share of GDP reflects the fact that average labor productivity also rose by a similar amount, on average.²

[figure 1 about here]

1.2 Sensitivity to the World Cycle

Chile is a small, open economy that is affected by fluctuations in the world economy. Shifts in world demand directly affect the prices of Chile's main exports and may also affect volumes. Fiscal and monetary policies in the main economies influence financial conditions at the global level. Together with changing sentiment in financial markets, these determine capital flows to emerging economies, including Chile. During the past decade and a half, Chile demonstrated a rather close association between external indicators and domestic economic growth (see figure 2).

[figure 2 about here]

1.3 Unemployment and Private Consumption

The Chilean economy exhibits a negative correlation between consumption and unemployment. This inverse relationship is apparent in figure 3. Higher employment rates coincide with slower annual growth in spending on nondurable consumer goods. The unemployment rate can be understood as an indicator of the level of household uncertainty and expectations. This means that the higher unemployment, the more households reduce their consumption, probably out of caution. Moreover, high unemployment implies reduced household income, and this liquidity restriction translates into reduced spending on consumption. Consequently, growth in aggregate consumption, far from behaving at random, is highly correlated with the economic cycle.

[figure 3 about here]

1.4 Importance of the Imported Component of Domestic Expenditure

By being open to foreign trade, a small economy such as Chile resorts to international markets to meet some of its domestic demand requirements. This means that, for example, imports of capital goods account for almost all investment in machinery. Indeed, virtually all durable goods purchases involve imports. Figure 4 reveals not only the relevance of import volumes for some components of domestic demand, but also the stability of this relationship over time. Furthermore, the discrepancies between spending on durable consumer goods and imports of these goods largely reflect inventory accumulation. Figure 5 shows that rising imports of consumer goods and changes in investment in inventories (both on average for four moving quarters) are closely related. The importance of foreign trade to the

so their share of GDP is measured through labor costs (CL). The second, in contrast, do not have access to this benefit and therefore their wages are considered to be a percentage of average nominal wages in the economy. This is assumed to be 60 percent.

2. When labor income's share of output is calculated from 1986 the variable seems to show a different tendency. In a regression, however, the coefficient accompanying this trend reaches 0.001 which, while statistically different from zero, is of little enough magnitude to assume that labor's share is constant.

different components of domestic demand also means that the real exchange rate is an important variable that influences domestic spending decisions.

[figures 4 and 5 about here]

1.5 Financial Markets throughout the Economic Cycle

The relationship between monetary aggregates, interest rates, and output has been the subject of many studies.³ These monetary aggregates, particularly real M1A, and the structure of interest rates generally led economic activity in recent decades. Output growth, M1, and the difference between long-run interest rates (based on the Central Bank's eight-year adjustable bond, or PRC8) and short-run interest rates (MPR) are depicted in figure 6. In the structural models presented below, money is not a transmission channel for monetary policy, whereas interest rates are, because money does not add information beyond that contained in other explanatory variables. Money has not proved useful for predicting inflation or any of the other variables included in the model.

[figure 6 about here]

1.6 Factors Determining the Surcharge on External Financing

A key variable for expenditure decisions within the economy, both directly and indirectly, is the financing surcharge that domestic agents must pay on external debt, because of its impact on domestic interest rates. Although there are no measurements of this surcharge over a long period of time, it is possible to construct approximations. As figure 7 indicates, trends in the external financing surcharge are consistent with a world in which solvency and liquidity are important. Until 1997, periods of high deficits in Chile's current account were accompanied by relatively significant increases in its spread, which may indicate that external financing became more costly as demand grew relative to the size of the economy.⁴ This relationship seems to break down after the Asian crisis and financial turbulence in Russia and other economies. Evidence also shows, however, that the financial surcharge in Chile is associated with the financial surcharge paid by companies in similar risk categories in the United States.⁵ This surcharge has risen significantly since 1997.

We refer to the premium surcharge or spread affecting agents who issue debt abroad as the external financing surcharge (REXF). These costs are based on the risk level implicit in buying the debt of a specific country. They can be estimated by looking at sovereign spreads or surcharges required by bonds issued by a given government compared to the return on nominal U.S. Treasury notes (that is, the T-note with a similar maturity).

[figure 7 about here]

1.7 Inflation, Inflation Targeting, and the Economic Cycle

The Central Bank's use of inflation targeting since the beginning of the 1990s has proved successful in terms of coordinating agents' expectations. Annual inflation tended to fall following a gradual reduction in inflation targets (figure 8). Although factors associated with indexation can introduce

3. See for example Herrera and Rosende (1991); Rojas (1993); Herrera and Magendzo (1997); Bravo and Franken (2002); Belaisch and Soto (1998).

4. See Bernanke, Gertler, and Gilchrist (1996).

5. See the Central Bank's Monetary Policy Report of January 2001.

inertia in the inflationary process, inflation expectations and, in particular, the Central Bank's credibility in terms of achieving the target do affect inflation itself. Demand conditions in goods and factor markets also influence inflation. Simple measurements of output can be empirically associated with changes in inflation over the past fifteen years. The relation between these two variables has weakened since 1996, but this can be associated first with the peso appreciation and later with its depreciation (figure 9).

[figures 8 and 9 about here]

2. STRUCTURAL FORECAST MODEL (MEP2)

As mentioned in the introduction, the different equations in the model describe both short-term movements in the economy and long-term equilibrium. It is in the latter sense that the model can be labeled as structural. The techniques used to estimate parameters for the different equations are therefore consistent with being able to distinguish short-term from long-term effects (that is, cointegration). These methods, as with all econometric methodology, are subject to important degrees of uncertainty. This uncertainty largely stems from the sensibility of the estimated parameters to the deep structure of the economy, which cannot be directly observed. To deal with situations in which the empirical estimation is poor, in which there are well-founded indications of structural changes in different relationships, or in which economic theory itself has important relationships that must be addressed, we opted for calibrating specific parameters, even though the calibrated value may be rejected using standard statistical methods.⁶ This calibration process is the second reason for calling these models structural.

A third reason, associated with the above, has to do with the many different legal restrictions on determining certain prices within the economy, particularly public utility charges. The Central Bank cannot ignore these facts, and they are explicitly incorporated into the modeling of the inflationary process.

To date, two structural forecast models are being developed at the Central Bank of Chile, known as MEP1 and MEP2. Qualitatively speaking, they share the characteristics described above. One of the main differences between MEP1 and MEP2 has to do with the degree of macroeconomic variable aggregation. MEP2 consists of aggregate demand, aggregate supply, and an equation that relates prices and economic activity. MEP2 expands MEP1 by estimating the different components of aggregate demand. It also incorporates the estimated evolution of the capital stock into the forecast of potential output. In addition to estimating aggregate demand and supply, MEP2 estimates the current account of the balance of payments (and, by definition, internal demand) and the REXF.

2.1 The Steady State in MEP1 and MEP2

The steady state refers to balanced growth trends within the economy, incorporating demand and supply conditions in goods and factor markets that are consistent with full employment of resources and constant relative prices. The main variables within the steady state are determined

6. By calibration we mean that in some equations, the constant and occasionally the slope parameters were restricted, in order to keep the equation consistent with the long-term equilibrium of an economy with a Cobb-Douglas production function.

endogenously in MEP2. The following equations summarize the conditions of the steady state first for MEP1, which encompasses only inflation, GDP, and financial market variables, and then for MEP2.

MEP1 steady state

$$Y = \bar{Y} ,$$

$$\text{INF4} = 3\% ,$$

$$\text{PRC8} = \bar{\text{PRC8}} ,$$

$$\text{MPR} = \bar{\text{MPR}} , \text{ and}$$

$$\text{RER} = \bar{\text{RER}} .$$

MEP2 steady state: aggregate supply

$$Y = A \cdot N^{\alpha_N} K_{\text{CONSTR}}^{\alpha_{K_{\text{CONSTR}}}} K_{\text{MACH}}^{1-\alpha_N-\alpha_{K_{\text{CONSTR}}}} ,$$

$$\alpha_N = \frac{[(1+\tau)\lambda + (1-\lambda)W]}{Y_N} ,$$

$$\frac{K_{\text{CONSTR}}}{Y} = \alpha_{K_{\text{CONSTR}}} C K_{\text{CONSTR}}^{-1} , \text{ and}$$

$$\frac{K_{\text{MACH}}}{Y} = \alpha_{K_{\text{MACH}}} C K_{\text{MACH}}^{-1} .$$

Aggregate demand and the external sector

$$\frac{\text{PC}_H}{\text{DPY}} = \phi_{C_H} ,$$

$$\frac{K_D}{C_H} = \phi_{K_{D0}} \cdot C K_D^{-\phi_{K_{D1}}} ,$$

$$\frac{\text{QM}_C}{C_D} = \phi_{\text{QM}_C} ,$$

$$\frac{\text{QM}_K}{\text{GFK}_{\text{MACH}}} = \phi_{\text{QM}_K} ,$$

$$\frac{\text{QM}_{\text{NLF}}}{Y} = \phi_{\text{QM}_{\text{NFL0}}} \cdot \text{RER}^{-\phi_{\text{QM}_{\text{NFL1}}}} , \text{ and}$$

$$\frac{\text{QX}_{\text{OTHER}}}{Y} = \phi_{\text{QX}_{\text{OTHER0}}} \cdot \text{YEX}^{-\phi_{\text{QX}_{\text{OTHER1}}}} \cdot Y^{-\phi_{\text{QX}_{\text{OTHER1}}}} \cdot \text{RER}^{-\phi_{\text{QX}_{\text{OTHER1}}}} .$$

Prices and costs

$$\text{INF4} = 3\% ,$$

$$\text{CPI} = (\text{MG} - \phi_{\text{MG}}) \text{CLU}^{0.68} \cdot \text{GW}^{0.16} \cdot \text{CIMP} ,$$

$$\text{CLU} = \frac{\text{PW}}{Y/N} (1 + \text{VAT}) ,$$

$$\text{CIMP} = \text{EXPI} \cdot \text{NER} (1 + \text{VAT}) (1 + \text{TAR}) , \text{ and}$$

$$W = \text{PW}^{0.83} \cdot \text{GW}^{0.17} .$$

Financial markets

$$\text{PRC8} = \text{REX}_{\text{LT}} + \text{RISK}_{\text{LT}} ,$$

$$\text{MPR} = \text{PRC8} - \rho , \text{ and}$$

$$\text{RER} = \text{RER}_{+1} .$$

The steady state of MEP2 is consistent with a Cobb-Douglas production function, while inflation and prices remain neutral. Potential output at each point in time therefore depends on the accumulated capital stock and normal resource utilization. Technical change is also exogenous and is reflected in total factor productivity (TFP) and the natural unemployment rate.

The accumulation of each type of capital depends on the cost of capital utilization, which is set by investment financing costs, that is, the long-term interest rate plus the respective depreciation rate, plus the price of capital measured as output units. The depreciation rate for each type of capital is assumed to be constant, but both interest rates and the relative price of capital in MEP2 are endogenous variables. Long-term interest rates are determined by conditions of international arbitrage using uncovered interest rate parity corrected for risk premiums and imposing a constant equilibrium real exchange rate. In the case of machinery and equipment, the relative price is directly affected by the real exchange rate, while the level of wages is more important for the relative price of construction.

As a result, the parity condition is key for determining interest rates in MEP2. The link with the rest of the model comes from the equilibrium between saving and investment. The sovereign risk premium is assumed to depend on the current account deficit as a percentage of GDP, which reflects imperfections in international capital markets. The dynamics of domestic expenditure affect financing conditions.

Private consumption of nondurable goods converges to a constant fraction of private disposable income, while the purchase of durable goods is corrected to reach the desired stock of durable goods, which depends on the cost of durable versus nondurable consumption goods. Thus, in the steady state, purchases of durable goods are such that they allow us to keep the ratio of durable stock to nondurable consumption constant.

The public sector affects the model through its income and expenditure policies, in the context of achieving a structural surplus set at 1 percent

of GDP. This leads to a rule for the behavior of capital and current public expenditure. Revenues are a function of cyclical conditions that affect activity and expenditure, but include an underlying tendency.

The external accounts depend on expenditure decisions. The volumes of imported consumption and capital goods approach a constant fraction of durable purchases and gross capital formation in machinery. In this sense, the equilibrium real exchange rate indirectly affects these expenditure components by affecting the capital costs of durable consumption goods and of machinery and equipment. Similarly, imports of intermediate nonfuel goods tend toward a constant fraction of GDP, which depends on the real exchange rate. The import volumes of intermediate nonfuel goods evolve according to simple rules. A simple rule is also used for the evolution of imports of nonfactorial services. Altogether, the main exports are forecast using sector-specific information regarding production plans. An econometric approximation is used solely for products other than major exports, which depend on the growth of the country's main trading partners and the real exchange rate.

The block including prices, wages, and the labor market reflects the neutrality of monetary policy in the long term. Growth in the cost of labor in real terms is equal to growth in average labor productivity. As a result, the increase in nominal wages is equal to growth in real wages plus inflation, which is stable and equal to the steady-state target. This ensures that the model remains consistent with the Cobb-Douglas production function, as does our treatment of the factoral distribution of income, which remains constant. This means that in the long-term, the elasticity of employment to real wages and the elasticity of employment to output have a value of one. Although there is ample international evidence relating unemployment to the level of real wages, in this case the natural unemployment rate is assumed to be exogenous.

Finally, in the long run the policy rule for the monetary policy rate tends toward a neutral monetary policy position, which is consistent with full employment of productive resources and inflation in line with the target. This "neutral" monetary policy rate is given externally in MEP1, while in MEP2 it results from an interest rate structure consistent with a stable real exchange rate.

2.2 The Functioning of Financial Markets

Both models (MEP1 and MEP2) share a block that describes the functioning of financial markets in Chile. This block includes three ingredients: first, the way movements in the monetary policy rate are transferred in the short term to other market interest rates and the real exchange rate; second, how private sector demand for money is determined; third, the rule that determines monetary policy rate movements.

With regard to the first point, when markets are functioning normally, long-term rates (PRC8) reflect arbitrage conditions affecting investment alternatives, particularly short-term instruments, so the expected behavior and level of the monetary policy rate and inflation (INF) influence the value of these long-term instruments. The same happens with other short-term instruments, such as nonindexed thirty- to eighty-nine-day deposit rates. Nominalizing the monetary policy rate reduced its impact on inflation, which makes it necessary to suitably correct econometric estimates for any simulation or forecast exercise.

[figure 10 about here]

Another sphere in which arbitrage conditions should be expected is the foreign currency exchange, particularly under the floating exchange rate system in effect in Chile. The foreseeable performance of interest rate differentials affects the financial cost associated with holding positions in one currency or another, thus affecting the value of the exchange rate. The empirical evidence regarding the validity of the uncovered interest rate parity is extremely weak. It does, however, offer a theoretical framework consistent with rational expectations and market arbitrage, so in general some version of this theory is applied to carry out forecasts and simulations.

The actual level of economic activity, represented by the gross domestic product (Y), is typically associated with the volume of transactions within the economy. Thus, the demand for real balances to carry out these transactions depends on Y along with the alternative cost of money, reflected in the nonindexed short-term deposit rate.

Finally, because the operational instrument used by the Central Bank is a target for the nominal interbank rate, some behavioral rule for this variable must be introduced. This is no minor point, because if we don't apply a reasonable policy rule, the model's growth and inflation forecasts will diverge in the presence of surprises on the aggregate demand side. If faced, for example, with an unexpected increase in economic growth, expected inflation will also rise. With a constant monetary policy rate, real ex ante rates in the economy fall, which in turn further increases the aggregate demand impulse and generates more inflationary pressures.

A considerable amount of literature deals with monetary policy rules.⁷ The next section contains a more detailed discussion of this point. In any case, evaluating different kinds of policy rules is not the central objective of this paper. In practice, to carry out official growth and inflation forecasts, the Central Bank uses the assumption that the monetary policy rate will remain constant over an eight-quarter horizon. It is enough to emphasize the importance of specifying a response from monetary policy to inflation deviations from the target to be able to complete macroeconomic models and use them to carry out simulations, such as those presented below.

Demand for Money

Chile's Central Bank uses the interest rate as its monetary policy instrument. As a result, demand for money is determined in a residual fashion within the monetary policy stance. Broad money's performance thus depends on output and the nominal interest rate, and it serves to forecast the quantity of money that the economy will require. The Central Bank has no target for the evolution of these aggregates.

The cointegration vector relates the behavior of the (logarithm of the) seasonally adjusted real money ($\log M_1$);⁸ the seasonally adjusted GDP ($\log Y$) and a transformation of the nonindexed thirty- to ninety-day deposit rate (RND). A dummy variable is included for the third quarter of 1988. The OLS results are as follows:

7. For a comprehensive review of the relevant literature, see Taylor (1993) and Clarida, Galí, and Gertler (1999).

8. All seasonal adjustments have been made using the standard X12-ARIMA method.

$$\begin{aligned} \log M1 = & -9.34 + 1.06 \log Y - 0.13 \log \left(\frac{\text{RND}}{1 + \text{RND}} \right) \\ & - 0.60 \left[\log M1_{-1} + 9.34 - 1.06 \log Y_{-1} + 0.13 \log \left(\frac{\text{RND}}{1 + \text{RND}} \right)_{-1} \right] \\ & + \sum_{i=1}^2 c_i \Delta \log Y_i + \sum_{i=1}^2 d_i \Delta \log \left(\frac{\text{RND}}{1 + \text{RND}} \right)_i + D883, \end{aligned} \quad (1)$$

where the numbers in parentheses are Newey-West corrected t statistics, the adjusted R squared is 0.99, and the average quadratic error is 2.0 percent. The LM serial correlation test (four lags) resulted in $F = 0.227$ (with a p value of 0.922); the Jarque-Bera normality test resulted in $\chi^2 = 3.654$ (with a p value of 0.161); and the White heteroskedasticity test resulted in $N \cdot R^2 = 0.449$ (with a p value of 0.970). The estimation period is 1986:4 to 2001:1. Both the magnitudes of interest rate and income elasticities are in line with previous findings.⁹

Uncovered Interest Parity Condition

The exchange rate is a key relative price for a small, open economy like Chile. To model this variable, we use uncovered interest rate parity. We assume that the expected real exchange rate involves three factors: the future exchange rate consistent with the model's own forecast; inertial expectations, which only consider the lagged exchange rate; and expectations associated with the long-term real exchange rate ($\log \text{RER}_{\text{LT}}$). For the estimation, we impose the restriction that the sum of the coefficients of these three variables is one. The interest rate spread is calculated in real terms, taking the difference between the foreign interest rate (REX) and the real monetary policy rate (RMPR). The foreign interest rate is constructed using the real London interbank offered rate (LIBOR), the LIBOR spread, and the reserve requirement. The following instruments were used for the lead of the real exchange rate: lags of the (log) real exchange rate, lags and differences in real money, the difference between inflation and the target, the relative position of the exchange rate within the band, the output gap, lags of the monetary policy rate, lags of the nominal exchange rate, and lags of the multilateral exchange rate. The results of the two-stage least squares (2SLS) regression are as follows:

$$\log \text{RER} = 0.20 \log \text{RER}_{-1} + 0.63 \log \text{RER}_{+1} + 0.17 \log \text{RER}_{\text{LT}} + (\text{REX} - \text{RMPR}), \quad (2)$$

where the numbers in parentheses are Newey-West corrected t statistics, the adjusted R squared is 0.90, and the average quadratic error is 3.52 percent. The LM serial correlation test (four lags) resulted in $F = 1.433$ (with a p value of 0.000); the Jarque-Bera normality test resulted in $\chi^2 = 67.109$ (with a p value of 0.161); and the White heteroskedasticity test resulted in

9. See Mies and Soto (2000).

$N \cdot R^2 = 54.120$ (with a p value of 0.000). The estimation period is 1986:4 to 2001:3.

The theory of uncovered interest rate parity cannot be empirically validated in Chile, as is the case using international evidence.¹⁰ It has therefore been imposed. This restriction introduces some problems in the regression, however, which also occurs in the case of residue normality. In fact, the Jarque-Bera test allows us to conclude that the distribution of error is not normal.

Because Chile trades with a wide range of countries besides the United States, the real exchange rate affecting the competitiveness of Chilean products is the multilateral real exchange rate ($\log MRER$). That is, the weighted sum, by trading share, of bilateral real exchange rates. The difference between the bilateral and the multilateral real exchange rate is reduced to the difference in the index of external prices relevant to Chile ($\log EXPI$) and the U.S. consumer price index (CPI) ($\log CPI_{US}$):¹¹

$$\log MRER = \log RER + \log EXPI - \log CPI_{US}. \quad (3)$$

To explain the behavior of the external financing surcharge (REXF), an equation was estimated by 2SLS. The external financing surcharge is an endogenous variable of the model. Explanatory variables are the current account deficit (CAD) and the spread affecting category A firms from the United States (RAM). The instruments used for this estimation were the changes in the terms of trade, the residuals from durable and nondurable consumption equations, and investment (construction and machinery). The resulting parameters are the following:

$$REXF = \phi + 0.13CAD + 0.89RAM. \quad (4)$$

The hypothesis that the parameter for the surcharge on category A firms is one cannot be rejected. This result is reasonable given that Chile's sovereign debt enjoys the same rating.

Long-Term Real Exchange Rate

In the long term, there is a relationship between the exchange rate, the terms of trade, public expenditure, and net international assets. The variables that are important for estimating the long-term exchange rate are the logarithm of the real exchange rate ($\log RER$), net international assets as a percentage of GDP (IA), the logarithm for the terms of trade ($\log TOT$), and total factor productivity (TFP). In its steady state, however, a constant exchange rate is imposed in this model, so that the nominal exchange rate behaves according to the differential between local and foreign inflation.

Monetary Policy Rule

For the purposes of our simulation exercises, we specify a reaction function for Central Bank policy that leaves some degree of freedom of choice in the parameters. We use a linear specification for the sake of simplicity. The policy rule associates the nominal monetary policy rate (MPR) with

10. See Engel (1995); Flood and Taylor (1996); Isard (1995); McDonald and Taylor (1992); Lewis (1994).

11. Feliú (1992) describes the methodology for building an external price index.

expected inflation, the output gap, and the lagged and expected gap between expected inflation and target inflation. A constant reflects the neutral instance for monetary policy.

Monetary policy reacts to expected inflation, not only because of deviations from the target, but also because expected inflation affects real ex ante rates within the economy, which are those that ultimately influence consumption and investment decisions. We also include the output gap in this policy rule, not necessarily because full employment is one of the Central Bank objectives, but rather because this is one of the main variables affecting medium-term inflationary pressures.¹² In addition, monetary policy may experience some inertia over time, which makes sharp movements in interest rates are generally undesirable owing to the volatility they could potentially introduce into financial markets. Furthermore, some analysts argue that a gradualist monetary policy is best in the face of uncertainty.¹³

Similarly, alternative policy rules can incorporate other arguments, such as the current account of the balance of payments, or possess nonlinearities, the result of the existence of a target range rather than a target point. These considerations can lead to monetary policy being more aggressive in one direction or another. The monetary policy rule proposed here is of the following form:¹⁴

$$\text{MPR} = \text{INF4}^E + \phi_{R_0} + \phi_{R_1} (\text{INF4}^E - 3\%) + \phi_{R_2} \text{GAP} + \phi_{R_3} \text{MPR} . \quad (5)$$

This policy rule is appropriate for the current nominal scheme. Nonetheless, most of the estimations carried out in this and other sections of the paper include the period during which the MPR was set in indexed terms. To be able to use these models to forecast within the current stance, we use the Fischer equation, which indicates that the real ex ante rate (RMPR) is equal to the nominal rate minus expected annual inflation:

$$\text{RMPR} = \text{MPR} - \text{INF4}^E . \quad (6)$$

Market Interest Rates

Monetary policy is transmitted to other interest rates because of the natural arbitrage inherent in Chile's financial markets. Short-term deposit rates affect the demand for real balances, as do long-term indexed rates, which play a decisive role in economic agents' spending decisions.

Demand for monetary balances depends on their alternative cost, which is associated with the short-term nominal deposit rate. This reacts to movements over time in the MPR and a margin associated with the cost of funds to the banking system:

$$\text{RND} = \phi_{\text{CAP}} + 0.18 \text{RND}_{+1} + 0.82 \text{MPR} - 1.83 \text{D981} - 1.37 \text{D983} , \quad (7)$$

(3.24)
(-9.27)
(-3.25)

12. Svensson (1997) and Agénor (2002) emphasize this point. For Chile, the same argument can be found in García, Herrera, and Valdés (2002).

13. Woodford (1999).

14. Morandé (2002) argues that for part of the 1990s, the current account deficit was associated with monetary policy issues. Medina and Valdés (2002b) reveal the implications of this type of policy rule in terms of how interest rates respond to inflation and the capacity gap. Medina and Valdés (2002a) study the implications of nonlinearities in inflation targeting, including the target range, with regard to the aggressiveness of monetary policy.

where the numbers in parentheses are Newey-West corrected t statistics, the adjusted R squared is 0.93, and the average quadratic error is 8.7 percent. The LM serial correlation test (four lags) resulted in $F = 0.354$ (with a p value of 0.838); the Jarque-Bera normality test resulted in $\chi^2 = 3.125$ (with a p value of 0.797); and the White heteroskedasticity test resulted in $N \cdot R^2 = 2.609$ (with a p value of 0.047). The estimation period is 1994:3 to 2001:2.

With regard to real long-term rates, the yield curve reflects arbitrage conditions between short- and long-term rates, represented by a version of the expectation hypothesis. This indicates that the difference between long-term Central Bank indexed bond (PRC8) rates and the short-term rate (RMPR) reflect expectations of capital losses or gains associated with holding these bonds. This can be translated in the long-term bond rate as a weighted average of the expected value of this rate and the short-term rate, where the weighting factor depends on the long-term bond's duration.¹⁵ As in the uncovered parity equation, we assume that expectations about the long-term rate depend on lags and leads of the same variable. The estimation therefore relies on instrumental variables.

The instruments used are the difference between the CPI and the target, the real exchange rate and its difference, the exchange rate's position within the exchange rate band, the misalignment of the real exchange rate compared to trend value, long-term and deposit rate lags, the monetary policy rate and its lag, and the output lag gap:

$$\text{PRC8} = \phi_{\text{PRC8}} + \underset{(11.15)}{0.43} \text{PRC8}_{-1} + \underset{(14.62)}{0.53} \text{PRC8}_{+1} + \underset{(2.03)}{0.04} \text{RMPR} , \quad (8)$$

where the numbers in parentheses are Newey-West corrected t statistics, the adjusted R squared is 0.89, and the average quadratic error is 0.25 percent. The LM serial correlation test (four lags) resulted in $F = 0.944$ (with a p value of 0.448); the Jarque-Bera normality test resulted in $\chi^2 = 2.885$ (with a p value of 0.236); and the White heteroskedasticity test resulted in $N \cdot R^2 = 26.061$ (with a p value of 0.000). The estimation period is 1990:1 to 2001:2.

We cannot reject the hypothesis that the sum of the coefficients accompanying the lags and leads in the PRC8, plus the RMPR, add up to one. Moreover, a constant is incorporated to reflect the existence of a premium for long-term maturity.

2.3 Aggregate Demand

The effect of the monetary policy rate is transmitted to aggregate demand via the functioning of financial markets. MEP1 uses a direct approximation of this problem, in which it models GDP excluding sectors associated with natural resources, such as fishing, mining, electricity, gas, and water (YRA). This provides the general impact of interest rates and the exchange rate on activity, but it is unable to identify precisely in which expenditure component these effects are produced. In MEP2, financial conditions affect

15. Campbell, Lo, and McKinlay (1997) provide a detailed analysis of the expectation hypothesis, while Blanchard (1984) and Blanchard and Fischer (1989) apply this theory in a simple macroeconomic model.

different components of expenditure separately, which allows us to identify monetary policy transmission channels more accurately.

Aggregate demand (AD) is the sum of five components:

$$AD = PC + I + CG + X - M, \quad (9)$$

where PC denotes total private consumption, I denotes total investment, GC denotes government expenditure on final consumption goods, X total exports of nonfinancial goods and services and M total imports of nonfinancial goods and services, all expressed in constant 1986 pesos. In what follows we provide details on the estimation of each of these components.

Private consumption

Total private consumption (PC) can be broken down as follows:

$$PC = PC_D + PC_H, \quad (10)$$

where PC_D denotes private purchases of durable goods¹⁶ and PC_H denotes private consumption of nondurable or habitual goods. For the long term, it is assumed that the ratio of nondurable goods to disposable private income (DPY) is constant. Disposable private income is calculated as disposable domestic income minus public sector income. Disposable domestic income is obtained from GDP, corrected for net external income and the changes in the terms of trade. The short-term dynamic includes unemployment (U) as an indicator of household perception of uncertainty and expectations. The equation for the short-term dynamic, including error correction, is as follows:

$$\begin{aligned} \Delta \log PC_H = & \phi_{PC_{H_0}} - 0.11 \left(\log PC_{H_{-1}} - \log DPY_{-1} - \phi_{PC_{H_1}} \right) - 1.04 \cdot \frac{1}{2} \sum_{i=0}^1 U_{-i} - 1.59 \cdot \frac{1}{3} \sum_{i=0}^2 PRC8_{-i} \\ & + 0.26 \cdot \frac{1}{2} \sum_{i=1}^2 (PRC8_{-i} - MPR_{-i}) - 0.53 \Delta \log PC_{H_{-1}} - 0.49 \Delta \log PC_{H_{-2}} \\ & - 0.28 \Delta \log PC_{H_{-3}} + 0.09 \Delta \log DPY + 0.04 D894 + 0.05 D984, \end{aligned} \quad (11)$$

where the numbers in parentheses are Newey-West corrected t statistics, the adjusted R squared is 0.63, and the average quadratic error is 1.1 percent. The LM serial correlation test (four lags) resulted in $F = 0.196$ (with a p value of 0.660); the Jarque-Bera normality test resulted in $\chi^2 = 0.985$ (with a p value of 0.611); and the White heteroskedasticity test resulted in $N \cdot R^2 = 19.919$ (with a p value of 0.867). The estimation period is 1987:2 to 2000:4.

The error correction term indicates a half-life of deviations from the long-term value totaling a little over three quarters. Changes in growth rates for disposable private income affect consumption of nondurable goods in the short term. This is consistent with assuming that at least part of the population makes consumption decisions based on current rather than permanent

16. The purchase and stock of durable goods are constructed using the methodology proposed by Gallego and Soto (2000).

income.¹⁷ Thus, a 1 percent increase in disposable private income translates into a 0.09 percent increase in private expenditure on nondurable consumption goods. Also, a 1 percent increase in unemployment (or, to be more precise, in the moving two-quarter average introduced here) is associated with a 1 percent reduction in consumption of nondurable goods. Changes in long- and short-term interest rates also affect consumption in the short term. An average one-point increase during the current quarter and the last two quarters of the eight-year PRC reduces nondurable consumption by 1.6 percent, while a similar increase in the average short-term rate (MPR) over the previous two quarters produces a 0.3 percent decline in nondurable consumption.

For the purchase of durable goods, we assume that in the long term the ratio of the consumption of durable goods over the consumption of nondurable goods depends on the cost of use of durable goods (CK_D). The cost of use is calculated as the relative price, corrected for depreciation and the relevant interest rate.¹⁸ Moreover, we assume that the consumption of durable goods (which is different from the purchase of these goods) is a percentage of the stock of these goods (K_D) and therefore can be approximated using this last variable. The equation for the demand of durable goods in the short term is denoted by:

$$\begin{aligned} \Delta \log PC_D = & \phi_{CD_0} - 0.14 \left(\log K_{D_{-1}} - \log PC_{H_{-1}} + \log CK_{D_{-1}} \right) - 4.69 PRC8_{-1} - 0.75 \Delta \log PC_H \\ & + 2.69 \left(PRC8_{-1} - MPR_{-1} \right) - 1.40 \Delta \left(\log CPI_{DK} - \log CPI_{HK} \right) \\ & - 0.26 \Delta \log PC_{D_{-1}} + 0.16 D912 - 0.10 D913, \end{aligned} \quad (12)$$

where the numbers in parentheses are Newey-West corrected t statistics, the adjusted R squared is 0.73, and the average quadratic error is 5.1 percent. The LM serial correlation test resulted in $F = 0.402$ (with a p value of 0.671); the Jarque-Bera normality test resulted in $\chi^2 = 2.371$ (with a p value of 0.306); and the White heteroskedasticity test resulted in $N \cdot R^2 = 19.020$ (with a p value of 0.836). The estimation period is 1987:2 to 2001:1.

The equation shows that long-term deviations have a half-life of just under three quarters. The long-term interest rate negatively affects the purchase of durable goods in the short term. At the same time, some substitution occurs between durable and nondurable goods in the short term. When spending on nondurable goods rises by one percentage point, the growth rate for the purchase of durable goods falls by 0.8 points. A 1 percent increase in this rate (when the slope of the yield curve remains constant) reduces durable goods purchases by 4.7 percent one quarter later. Meanwhile, and also with a one-quarter lag, a 1 percent reduction in the spread between the long-term rate (PRC8) and the short-term rate (MPR) reduces durable goods purchases by 2.7 percent. Finally, a 1 percent increase in the comparative price resulting

17. This type of assumption is explained in detail and tested by Campbell and Mankiw (1989). For the case of the United States, the authors find that consumers who consume based on their current income account for about 50 percent of national income.

18. Both the cost of use of durable goods and the long-term relationship are first-order conditions for a model that deals with nondurable and durable goods. For more detail, see Obstfeld and Rogoff (1996).

from the ratio of the durable goods CPI (CPI_{DK}) over the nondurable goods CPI (CPI_{HK}) reduces durable goods purchases by 1.4 percent in the short term.

Investment

Total investment consists of the formation of fixed capital and inventory changes. Investment in fixed capital breaks down into gross formation in machinery (GFK_{MACH}) and gross formation in construction (GFK_{CONSTR}), which are estimated separately. In both cases we assume that the ratio of the stock of each type of capital (K_{MACH} and K_{CONSTR} , respectively) to GDP in the long term depends inversely on the cost of use of capital (CK_{MACH} and CK_{CONSTR} , respectively). This means that the ratio of gross formation of each kind of capital to the respective stock is constant in the long run. This ratio must be equal to the long-term growth rate of the economy plus the replacement of depreciated capital.¹⁹ Both long-term relations have been included in short-term estimations. In the case of machinery investment, the estimated equation is as follows:

$$\begin{aligned} \Delta \log GFK_{MACH} = & \phi_{FBM_0} - 0.71 \left(\log K_{MACH_{-2}} - \log Y_{-1} + \log CK_{MACH_{-1}} - \phi_{GFK_{MACH_1}} \right) \\ & - 0.33 \left(\log GFK_{MACH_{-1}} - \log K_{MACH_{-2}} - \phi_{GFK_{MACH_2}} \right) \\ & - 0.27 \Delta \log GFK_{MACH_{-1}} + 1.19 \Delta \log Y_{-3} - 0.53 \Delta \log CK_{MACH} - 2.29 \cdot \frac{1}{2} \sum_{i=1}^2 PRC8_{-i} \\ & + 1.19 \cdot \frac{1}{2} \sum_{i=1}^2 (PRC8_{-i} - MPR_{-i}) - 0.18 D944 - 0.15 D961, \end{aligned} \tag{13}$$

where the numbers in parentheses are Newey-West corrected t statistics, the adjusted R squared is 0.58, and the average quadratic error is 5.1 percent. The LM serial correlation test resulted in $F = 0.805$ (with a p value of 0.375); the Jarque-Bera normality test resulted in $\chi^2 = 1.814$ (with a p value of 0.404); and the White heteroskedasticity test resulted in $N \cdot R^2 = 24.636$ (with a p value of 0.648). The estimation period is 1987:3 to 2000:4.

The long-term price elasticity has been calibrated at 1.0, as dictated by the theory. Results show that deviations in the long-term relationship between capital stock, GDP, and the cost of use have a half-life of almost half a quarter. Meanwhile, deviations in the ratio of gross formation of stock over long-term levels, represented by $\phi_{GFK_{MACH_2}}$, have a half-life of just over one and a half quarters. Furthermore, with a three quarter lag, a change in GDP growth of 1 percentage point increases gross formation in machinery by 1.2 percent in the short term, revealing the procyclical behavior of these investments in the short term. Investment in machinery has also proved to be relatively sensitive to movements in long- and short-term interest rates. Given the slope of the yield curve, a 1 percent increase in the long-term interest rate, as a moving average over the previous two quarters, reduces

19. For more detail on deriving long-term relationships, see Bustos, Engel, and Galetovic (2000) and Bravo and Restrepo (2001).

growth of investment in machinery by 2.3 percent. Meanwhile, an average 1 percent increase over the previous two quarters in the slope of the yield curve reduces growth of gross formation in machinery by 1.2 percent. Finally, the cost of use of this kind of capital has both short- and long-term effects. Thus, an increase of one percentage point in the growth of the cost per use of machinery reduces this kind of capital by 0.5 percent.

The equation for the short-term dynamic of gross formation in construction is expressed as

$$\begin{aligned}
\Delta \log \text{GFK}_{\text{CONSTR}} = & \phi_{FBC_0} - 0.13 \left(\log K_{\text{CONSTR}_{-3}} - \log Y_{-2} + \log \text{CK}_{\text{CONSTR}_{-2}} - \phi_{FBC_1} \right) \\
& - 0.14 \left(\log \text{GFK}_{\text{CONSTR}_{-2}} - \log K_{\text{CONSTR}_{-3}} - \phi_{\text{GFK}_{\text{CONSTR}_2}} \right) + 0.60 \Delta \log Y_{-1} \\
& - 0.33 \Delta \log \text{GFK}_{\text{CONSTR}_{-1}} + 0.21 \Delta \log \text{GFK}_{\text{CONSTR}_{-3}} - 2.38 \cdot \frac{1}{2} \sum_{i=3}^4 \text{PRC8}_{-i} \\
& + 0.04 \Delta \text{LIG}_{-1} - 0.10 \text{D881} + 0.06 \text{D924},
\end{aligned} \tag{14}$$

where the numbers in parentheses are Newey-West corrected t statistics, the adjusted R squared is 0.69, and the average quadratic error is 2.1 percent. The LM serial correlation test resulted in $F = 0.338$ (with a p value of 0.564); the Jarque-Bera normality test resulted in $\chi^2 = 1.518$ (with a p value of 0.468); and the White heteroskedasticity test resulted in $N \cdot R^2 = 10.141$ (with a p value of 0.996). The estimation period is 1987:3 to 2000:4.

In this case, corrections to deviations from the long-term steady state are significant with a two-quarter delay, because investment accounting in construction is closely tied to building permits. Deviations from the long-term steady state influence building permits and affect investment with some lag. Error correction for the relationship between capital stock, GDP, and the cost of use, as well as the ratio of gross formation in construction to construction stock over the long term, has a half-life of a little over two quarters. Gross formation in machinery also behaves procyclically. In the short term, an increase in GDP growth of one percentage point raises gross capital formation in construction by 0.6 percent, with a one-quarter lag. Interest rates also affect this type of capital, although with somewhat more of a delay than in the case of machinery. An increase in the eight-year PRC (average for the third and fourth lag) of one percentage point leads to a fall in investment in machinery of 2.4 percent. Meanwhile, we found no robust relationship between the slope of the yield curve and investment in construction. We also observed that an increase in the growth rate of public investment (GI) of 1 percentage point increased growth in total investment in construction by 0.04 percent. Although the relationship is weak, part of investment in construction denotes investment carried out by the public sector.

Finally, the short-term behavior of inventory changes or investment in inventory (IINV) should also be estimated. To do so, we assume that the inventory-to-GDP ratio remains constant in the long term. Given the long-term growth rate for GDP, this suggests that the ratio of investment in

inventories to GDP is also constant in the long term. The short-term dynamic is therefore expressed by the following equation:

$$\Delta \frac{\text{IINV}}{Y} = \phi_{\text{IINV}_0} - 0.48 \left(\frac{\text{IINV}_{-1}}{Y_{-1}} - \phi_{\text{IINV}_1} \right) - 0.27 \Delta \frac{\text{IINV}_{-1}}{Y_{-1}} + 0.22 \Delta \log M$$

(15)

$$+ 0.10 \Delta \log M_{-1} - 0.06 \text{D894} + 0.05 \text{D901},$$

(2.28)
 (-25.28)
 (6.56)

where the numbers in parentheses are Newey-West corrected t statistics, the adjusted R squared is 0.70, and the average quadratic error is 1.6 percent. The LM serial correlation test resulted in $F = 0.818$ (with a p value of 0.447); the Jarque-Bera normality test resulted in $\chi^2 = 0.677$ (with a p value of 0.713); and the White heteroskedasticity test resulted in $N \cdot R^2 = 21.064$ (with a p value of 0.176). The estimation period is 1987:1 to 2000:4.

The half-life of deviations in the long-term relationship is almost one quarter. For the short term, a relationship was found between changes in imports of goods and nonfinancial services (M) and investment in inventory. Thus, an increase in the growth rate of imports of one percentage point increased the ratio of the change of investment in inventories to GDP by 0.2 points with a one-quarter lag and 0.1 points with a two-quarter lag. This reflects that fact, as mentioned above, that an important portion of inventories comes from abroad.

Public Sector

Total public sector tax revenues including income from pension deductions (TT) have risen somewhat more quickly than gross domestic product. Econometric estimations show that a reasonable assumption for the short run is

$$\Delta \log \text{TT} = 1.05 \Delta \log Y. \tag{16}$$

This elasticity between domestic output and tax revenues reflects the increase in the taxable base as GDP rises and is the same as that used by the Finance Ministry to calculate structural expenditure.²⁰ This elasticity is assumed to converge to 1.0 in the long run for the model to have a well-defined steady state. Estimates show that government income from copper (GY_{CU}) is about 7 percent of total copper exports, a ratio that is relatively stable over time. Thus,

$$\text{GY}_{\text{CU}} = 0.07 (\text{PCU} \cdot \text{QCU} \cdot \text{NER}). \tag{17}$$

This allows us to calculate total government expenditure (GEXP_{TOT}) using a formula similar to that used by the national budget office to calculate the structural deficit, which must amount to one percent of potential GDP (YE). This formula represents variations in a logarithmic linearization, expressed as

20. See the Budget Office's *Dirección de Presupuestos* for 2001.

$$\begin{aligned} \Delta \log \text{GEXP}_{\text{TOT}} = & \phi_{\text{GEXP}_{\text{TOT}_1}} (\Delta \log \text{TT}_{-1} + 1.05 \Delta \log \text{YE} - 1.05 \Delta \log Y_{-1}) \\ & + \phi_{\text{GEXP}_{\text{TOT}_2}} \Delta \log \text{GY}_{\text{CU}} - 0.01 \phi_{\text{GEXP}_{\text{TOT}_3}} \Delta \log \text{YE}, \end{aligned} \quad (18)$$

where

$$\phi_{\text{GEXP}_{\text{TOT}_1}} = \frac{\text{TT}_{-1} (\text{YE}_{-1} / Y_{-1})^{1.05}}{\text{GEXP}_{\text{TOT}_1}}, \quad (19)$$

$$\phi_{\text{GEXP}_{\text{TOT}_2}} = \frac{\text{GY}_{\text{CU}_{-1}}}{\text{GEXP}_{\text{TOT}_1}}, \text{ and} \quad (20)$$

$$\phi_{\text{GEXP}_{\text{TOT}_3}} = \frac{\text{YE}_{-1}}{\text{GEXP}_{\text{TOT}_1}}. \quad (21)$$

Based on total government expenditure, current expenditure (GEXP_{CUR}) can be estimated as

$$\text{GEXP}_{\text{CUR}} = 0.82 \text{GEXP}_{\text{TOT}}. \quad (22)$$

Current income (GY_{CUR}), meanwhile, is the sum of tax revenues and income from copper (GY_{CU}) and other sales (GY_{OTHER}). The latter account for about 23 percent of current income:

$$\text{GY}_{\text{CUR}} = \text{GY}_{\text{CU}} + \text{TT} + \text{GY}_{\text{OTHER}} = \frac{\text{GY}_{\text{CU}} + \text{TT}}{0.77}. \quad (23)$$

The difference between current income and current expenditures corresponds to government saving. By adding this to government consumption expenditure, we obtain the part of disposable national income corresponding to government revenue:

$$\text{GY} = \text{GC} + \text{GY}_{\text{CUR}} - \text{GEXP}_{\text{CUR}}. \quad (24)$$

This income, GY , allows us to calculate disposable private income. The government's expenditure on consumption, calculated by the National Accounts department, is forecast according to the following assumption:²¹

$$\Delta \log \text{GC} = \phi_{\text{GC}}, \quad (25)$$

in which the constant is calibrated according to the information available on changes in the main government expenditures. The calculation considers personnel and goods and services expenditures, which account for a little over half the government's expenditure on consumption. In recent years this variable has risen by around 35 percent per year.

21. Government expenditure on consumption has been converted to quarters using changes in spending on personnel and goods and services from public finance.

Government investment, which is part of gross capital formation, is obtained as a residue starting from the following identity:

$$GEXP_{TOT} = GC + GI + GEXP_{OTHER} , \quad (26)$$

that is, total government expenditure can be broken down into consumption expenditure, investment expenditure, and other expenditure, where it is assumed that $GEXP_{OTHER}$ grows at the same rate as total government expenditure. With this assumption, we use the calculation for total government expenditure presented above and the forecast for government consumption to obtain a forecast for government investment.

External sector

The external sector can be divided into exports and imports of goods, nonfinancial services, and financial services. Variables for exports and imports are estimated using volumes based on 1986 dollars. The volume for total exports (QX_{GROSS}) can be calculated as the following sum of components:

$$QX_{GROSS} = QX_{PRINC} + QX_{OTHER} , \quad (27)$$

where QX_{PRINC} denotes exports of principal goods (copper and noncopper) and QX_{OTHER} denotes exports of other goods. The exports of principal goods are not forecast using econometric techniques, because the information regarding investment and production plans in these sectors is trustworthy enough to make econometric forecasts unnecessary. An econometric approximation is used, however, for the exports of other goods.

Total exports of goods in constant 1986 pesos (XG_{TOT}) are calculated using forecast quantum figures, by applying the following:

$$XG_{TOT} = QX_{GROSS} \cdot NER86 = (QX_{PRINC} + QX_{OTHER}) NER86 , \quad (28)$$

where $NER86$, is the average observed exchange rate in 1986.

We assume that the quantity of other, nonprincipal, exports is determined in the long run by both Chile's GDP and the GDP of the main trading partners (YEX), which is consistent with the applied theory of gravity for international trade. Long-term quantities also depend on the real exchange rate. The short-term dynamic is expressed by the following equation:

$$\begin{aligned} \Delta \log QX_{OTHER} = & \phi_{QX_{OTHER_0}} \left(-0.86 \log QX_{OTHER_1} - 1.30 \log Y_1 - 1.49 \log YEX_1 - 0.38 \log RER_1 - \phi_{QX_{OTHER_1}} \right) \\ & + 0.53 \Delta \log RER_{-1} + 0.59 \Delta \log RER_{-2} + 1.57 \Delta \log Y - 1.33 \Delta \log Y_{-1} , \end{aligned} \quad (29)$$

where the numbers in parentheses are Newey-West corrected t statistics, the adjusted R squared is 0.71, and the average quadratic error is 2.9 percent. The LM serial correlation test resulted in $F = 1.305$ (with a p value of 0.287); the Jarque-Bera normality test resulted in $\chi^2 = 0.784$ (with a p value of 0.676); and the White heteroskedasticity test resulted in $N \cdot R^2 = 12.987$ (with a p value of 0.674). The estimation period is 1991:2 to 2000:4.

In the long term, a 1 percent rise in the GDP of Chile's main trading partners increases the exports analyzed here by 1.5 percent. The long-term elasticity associated with Chile's GDP is 1.3 and the price elasticity associated with the real exchange rate is 0.4. The correction of deviations from the long-term relationship has a half-life of about one-fifth of a quarter. In the short term, a 1 percent rise in Chile's GDP increases minor exports by 1.6 percent, an effect that is partially reverted a quarter later. Meanwhile, an increase of one point in the real exchange rate increases short-term expansion of minor exports by 0.5 percent with a one-quarter lag and 0.6 percent with a two-quarter lag.

The quantity of total goods imports (QM_{GROSS}) can be broken down as the sum of the following components:

$$QM_{\text{GROSS}} = QM_C + QM_K + QM_{\text{INTERM}} = QM_C + QM_K + QM_{\text{FL}} + QM_{\text{NFL}}, \quad (30)$$

where QM_C denotes imports of consumption goods, QM_K denotes imports of capital goods, and QM_{INTERM} denotes imports of intermediate goods. The latter can be broken down into fuel (QM_{FL}) and nonfuel (QM_{NFL}). As with exports of goods, imports of goods are expressed in constant 1986 pesos using the following:

$$MG_{\text{TOT}} = QM_{\text{GROSS}} \cdot \text{NER86} = (QM_C + QM_K + QM_{\text{FL}} + QM_{\text{NFL}}) \text{NER86}, \quad (31)$$

For reasons similar to those provided for the exports of principal goods, fuel imports are also estimated using specialized information. In the long term, imports of consumption goods are assumed to be a constant share of the total purchase of durable goods. The equation describing short-term behavior is:

$$\begin{aligned} \Delta \log QM_C = & \phi_{QM_C} - 0.07 \left(\log QM_{C,t-1} - \log PC_{D,t-1} - \phi_{QM_C} \right) + 0.51 \Delta \log PC_D \\ & + 0.11 \Delta \log PC_{D,t-1} - 0.35 D901, \end{aligned} \quad (32)$$

where the numbers in parentheses are Newey-West corrected t statistics, the adjusted R squared is 0.65, and the average quadratic error is 5.4 percent. The LM serial correlation test resulted in $F = 0.520$ (with a p value of 0.597); the Jarque-Bera normality test resulted in $\chi^2 = 2.695$ (with a p value of 0.260); and the White heteroskedasticity test resulted in $N \cdot R^2 = 5.966$ (with a p value of 0.743). The estimation period is 1986:3 to 2001:1.

The long-term adjustment is rather slow, with a half-life of error totaling almost four quarters. Changes in durable goods purchases affect consumption imports in the short term: a 1 percent increase in purchases of durable goods is associated with a 0.5 percent rise in consumption goods with a one-quarter lag and 0.1 percent rise with a two-quarter lag.

To estimate the behavior of capital goods imports we assume that in the long term, they tend to a constant percentage of total investment in machinery. The equation describing short-term changes in these imports is expressed as:

$$\Delta \log QM_K = \phi_{QM_{K_0}} - 0.07 \left(\log QM_{K_{-1}} - \log GFK_{MACH_{-1}} - \phi_{QM_{K_1}} \right) + 1.02 \Delta \log GFK_{MACH} \quad (33)$$

$$+ 0.12 \Delta \log QM_{K_{-1}} - 0.13 D984,$$

(2.74) (-15.55)

where the numbers in parentheses are Newey-West corrected t statistics, the adjusted R squared is 0.88, and the average quadratic error is 3.1 percent. The LM serial correlation test resulted in $F = 0.316$ (with a p value of 0.730); the Jarque-Bera normality test resulted in $\chi^2 = 1.131$ (with a p value of 0.568); and the White heteroskedasticity test resulted in $N \cdot R^2 = 17.046$ (with a p value of 0.048). The estimation period is 1986:3 to 2001:1.

As in the case of consumption goods imports, this equation shows a relatively slow long-term adjustment, with a half-life of deviations of somewhat less than one year. Changes in capital imports seem to follow changes in investment in machinery rather closely, with a coefficient of 1.0 for this last variable. Long-term deviations thus tend to be infrequent, but persistent.

Finally, intermediate, imports of nonfuel goods are estimated assuming that these maintain a constant ratio to GDP in the long term, depending on the real exchange rate. The equation for demand for these imports is expressed as

$$\Delta \log QM_{NFL} = \phi_{QM_{NFL_0}} - 0.50 \left(\log QM_{NFL_{-1}} - \log Y_{-1} + 1.09 \log RER_{-1} + \phi_{QM_{NFL_1}} \right)$$

$$+ 1.79 \Delta \log Y + 1.06 \Delta \log Y_{-1} - 0.55 \Delta \log RER_{-1} \quad (34)$$

(3.73) (2.24) (2.98)

$$+ 0.28 \Delta \log QM_{NFL_{-3}} - 0.08 D962 - 0.08 D912,$$

(2.63) (-5.26) (-4.59)

where the numbers in parentheses are Newey-West corrected t statistics, the adjusted R squared is 0.61, and the average quadratic error is 3.7 percent. The LM serial correlation test resulted in $F = 0.358$ (with a p value of 0.041); the Jarque-Bera normality test resulted in $\chi^2 = 2.016$ (with a p value of 0.365); and the White heteroskedasticity test resulted in $N \cdot R^2 = 12.521$ (with a p value of 0.819). The estimation period is 1988:2 to 2001:1.

In the long term, a 1 percent increase in the real exchange rate translates into an estimated 1.1 percent increase in the imports analyzed here. Long-term deviations have a half-life of about one quarter. In the short term, these imports increase faster than GDP. A 1 percent increase in GDP leads to a short-term rise of 1.8 points in intermediate, nonfuel goods imports with a one-quarter lag and an increase of 1.0 points with a two-quarter lag. The real exchange rate also negatively affects these imports in the short term. An increase in the moving average (a contemporary variable and a lag) for the real exchange rate leads to a 0.6 percent decline in these imports.

It is also necessary to estimate imports and exports of nonfinancial services, financial services, and net transfers. We assume that imports of nonfinancial services represent a constant percentage of goods imports in the long term. The short-term dynamic is expressed as

$$\Delta \log MS = \phi_{MS_0} - 0.07 \left(\log MS_{-1} - \log MG_{TOT_1} - \phi_{MS_1} \right) + 0.46 \Delta \log MG_{TOT_2} \quad (35)$$

$$- 0.26 \Delta \log MS_{-1} - 0.20 \Delta \log MS_{-2} + 0.29 D881,$$

where the numbers in parentheses are Newey-West corrected t statistics, the adjusted R squared is 0.50, and the average quadratic error is 5.4 percent. The LM serial correlation test resulted in $F = 0.325$ (with a p value of 0.571); the Jarque-Bera normality test resulted in $\chi^2 = 2.082$ (with a p value of 0.353); and the White heteroskedasticity test resulted in $N \cdot R^2 = 10.773$ (with a p value of 0.630). The estimation period is 1986:4 to 2001:1.

As with nonfinancial services imports, we assume that nonfinancial services exports represent a constant ratio to total exports of goods in the long term. For these exports, the short-term dynamic is expressed as

$$\Delta \log XS = \phi_{XS_0} - 0.40 \left(\log XS_{-1} - \log XG_{TOT_1} - \phi_{XS_1} \right) + 0.39 \Delta \log XG_{TOT_2} + 0.90 \Delta \log YS_{-2} \quad (36)$$

$$- 0.34 \Delta \log XS_{-1} - 0.56 \Delta \log Y_{-3} + 0.07 D984,$$

where the numbers in parentheses are Newey-West corrected t statistics, the adjusted R squared is 0.48, and the average quadratic error is 3.0 percent. The LM serial correlation test resulted in $F = 0.371$ (with a p value of 0.693); the Jarque-Bera normality test resulted in $\chi^2 = 2.550$ (with a p value of 0.279); and the White heteroskedasticity test resulted in $N \cdot R^2 = 31.848$ (with a p value of 0.007). The estimation period is 1990:1 to 2000:4.

The current account

The current account of the balance of payments measured in current dollars (CAF) is obtained through the following sum:

$$CAF = XGF - MGF + XSF - MSF + BFSF + NTF, \quad (37)$$

where XSF denotes exports of nonfinancial services in foreign currency (current dollars), MSF denotes imports of nonfinancial services in foreign currency, BFSF denotes the balance of financial services in foreign currency, and NTF the net transfers from abroad in foreign currency. The volume of exports and imports of goods are estimated as explained above. The volume, expressed in 1986 dollars, is transformed into current dollars using the unit value index (*Índice de Valor Unitario*) for the corresponding exports and imports (UVIX and UVIM):

$$XGF = QX_{PRINC} \cdot UVIX_{PRINC} + QX_{OTHER} \cdot UVIX_{OTHER} \quad \text{and} \quad (38)$$

$$MGF = QM_C \cdot UVIM_C + QM_K \cdot UVIM_K + QX_{INTERM} \cdot UVIX_{INTERM} + QX_{NFL} \cdot UVIX_{NFL}. \quad (39)$$

Forecast figures for imports of nonfinancial services, in constant 1986 pesos, are translated into current dollars using the deflator for services imports and the nominal exchange rate. The conversion applied is

$$MSF = MS \left(\frac{PMS}{NER} \right), \quad (40)$$

where PMS denotes the deflator for nonfinancial services imports.

Exports of nonfinancial services are converted to current dollars using a similar formula to that used for nonfinancial services imports, multiplying the constant peso value by the deflator for nonfinancial services exports and dividing it by the nominal exchange rate. The unit conversion rate is

$$XSF = XS \left(\frac{PXS}{NER} \right). \quad (41)$$

Financial services are forecast using the stock of net international assets (IAF).²² The net balance for these services is expressed as

$$BFSF = RIA \cdot IAF, \quad (40)$$

where RIA denotes an average interest rate on net international assets. Finally, net transfers from abroad are forecast without using econometric approximations.

2.4 Aggregate Supply, Prices, and Costs

The final transmission of cyclical fluctuations in the economy receives a stylized treatment in MEP1, with a simple Phillips curve for the gap between GDP and potential GDP with the acceleration or deceleration of underlying inflation. Movements in the exchange rate also affect this gap. The effect of noncore components of inflation, such as perishable goods, fuel, and regulated fee inflation, is added in.

In MEP2, the transmission of shifts in aggregate demand to prices is described more explicitly through the explicit treatment of the labor market and margins. In the short term it is assumed that activity performs similarly to expenditure, so employment stems from derived demand, which in turn depends on the relative cost of labor and capital accumulation. The short-term equilibrium between supply and demand in the labor market determines the unemployment rate, affecting wage pressures. The effect of unit labor costs comes from the combination of wage pressures and trends in average labor productivity, while the cyclical conditions in the economy affect the foreseeable performance of sales margins. The sum of these elements, along with pressures from imported costs, determine the level and behavior of underlying prices. The prices of regulated services and fuels receive explicit treatment, as in MEP1.

In the model, aggregate supply in the economy reflects the cost structure in the long term. The technology is Cobb-Douglas, so the distribution of costs among factors is constant in the long term. This imposes restrictions on employment's performance, which is assumed to adjust to balance situations involving higher or lower real wages compared with average productivity. Similarly, wages are determined by institutional factors to a large degree.

22. This stock is updated using data on the surplus (deficit) in the current account: $IAF = IAF_{-1} + CAF$.

Indexation to past inflation has a significant impact on the short-term performance of wages, while public sector adjustments strongly affect the service component.

The retail price structure is consistent with another Cobb-Douglas distribution technique, which combines unit labor costs associated with the domestic production of consumption goods, import costs associated with imported supply components or with imported finished goods, and services.

Productive capacity

This section works with a Cobb-Douglas production function that relates the aggregate value of three kinds of inputs: private employment (PN), capital stock in construction (K_{CONSTR}), and capital in machinery and equipment (K_{MACH}). The employment considered corresponds to the total population of those employed minus employees in special employment programs, without subtracting those affected by the hiring bonus. Capital stocks include both the public and private sectors. Two additional variables come into play in the production function: total factor productivity (TFP), which corresponds to the technology level, and capital utilization (UT), which is assumed to be equal for the two kinds of capital.

$$Y = TFP \cdot NP^{0.53} \cdot K_{CONSTR}^{0.29} \cdot K_{MACH}^{0.18} \cdot UT^{0.47}. \quad (43)$$

The parameters of the production function are calculated as an average of the income share of each input. The capital utilization rate is associated with the unemployment rate (U).²³

$$UT = 1 - U. \quad (44)$$

TFP is obtained by breaking down growth sources in line with the production function. Because PN is used, total factor productivity includes improvements in education quality and hours worked.

Potential output is constructed by imposing a normal use rate for resources (with a natural unemployment rate) and cleaning procyclical movement out of TFP.²⁴ For trend TFP, a Hodrick-Prescott (HP) filter is used in which the parameter λ is set to 10,000 owing to the sensitivity of the method to values at the extreme limits of the sample.

$$\bar{Y} = \bar{TFP} \cdot LF^{0.53} \cdot K_{CONSTR}^{0.29} \cdot K_{MACH}^{0.18} \cdot \bar{UT}^{0.47}. \quad (45)$$

Finally, the capacity gap corresponds to the difference between the log of output and the log of potential output:

$$GAP = \log Y - \log \bar{Y}. \quad (46)$$

Labor demand

Imbalances in the distribution of factoral income are gradually corrected through changes in labor demand. The log-linear specification for labor

23. Based on Contreras and García (2002).

24. Although some factors introduce movement into the cycle (hours worked, level of effort, labor force), the evidence reveals that the procyclical movement remains even when it is controlled for (Contreras and García, 2002). We nonetheless control for the rate of utilization.

demand compares the logarithm of employment minus employment programs (logPN) with the logarithm for real, seasonally adjusted GDP (logY) and a long-run correction term for the participation of the labor factor (α_N).²⁵ In addition, the regression includes terms that explain employment and a dummy variable.

$$\Delta \log \text{PN} = \phi_{\text{PN}} - 0.14 \left(\ln \alpha_N - \ln 0.53^* \right) + 0.24 \Delta \log Y - 0.12 \Delta \log Y_{-1} + 0.20 \Delta \log Y_{-2} + 0.02 \text{D933}, \quad (47)$$

(-4.85)
(4.62)
(1.45)
(2.79)
(12.03)

where the numbers in parentheses are Newey-West corrected t statistics, the adjusted R squared is 0.47, and the average quadratic error is 0.77 percent. The LM serial correlation test (with 4 lags) resulted in $F = 0.564$ (with a p value of 0.690); the Jarque-Bera normality test resulted in $\chi^2 = 0.415$ (with a p value of 0.812); and the White heteroskedasticity test resulted in $N \cdot R^2 = 14.741$ (with a p value of 0.195). The estimation period is 1987:2 to 2001:3.

The constant for the correction vector is calibrated, so results are consistent with a constant distribution of income. To estimate this constant the wage bill is divided by nominal GDP (YN).

$$\alpha_N = \frac{\text{CL} \cdot \text{NW} + 0.6 \text{W} \cdot \text{NSE}}{\text{YN}}. \quad (48)$$

When calculating the wage bill it is necessary to weight two different types of workers, those who earn wages (NW) and those who are self-employed (NSE). The first contribute to social security, so their share of GDP is measured using labor costs (CL). The second, in contrast, do not have this benefit, and we thus consider their wage to be 60 percent of average nominal wages in the economy.

Private wages

The wage equation explains the behavior of nominal wages (logW). The wages used in this equation are average nominal wages in the economy, so they include both public and private wages. Nominal wage performance is explained by changes in the difference between unemployment (U) and its natural level (assumed to be 8 percent), the logarithm of the public wage adjustment index (logGWAI), and inflation during the previous semester (logCPI), owing to indexing clauses.

Theory indicates that in the long term, real private wages must grow proportionately to average labor productivity (LQ), ensuring that the factoral distribution of income remains constant; this is in fact observed empirically during the period under analysis (see the stylized facts in section 1). Public wages are therefore adjusted according to the wage adjustment index for government employees. To reach a balance, the increase in real wages must be composed of an increase in productivity and real growth in the government adjustment figure. Calibrating the regression constant, which corresponds to long-term productivity growth and private wages' share of wage growth, imposed this condition.

Because real wages cannot depend on inflation in the long term, the inflation term and wage adjustment coefficients must add up to one. The coefficient tests for both variables do not allow the rejection of the null hypothesis—that is, that these add up to one, so real wages do not depend on inflation in the long term.

25. Employment without employment programs (PN = N - PEE) does include hiring subsidies.

The results of the equation, estimated using OLS, are as follows:

$$\begin{aligned} \Delta \log W = & \left(1 - \frac{0.17}{(5.23)} \right) \Delta Q - \frac{0.08}{(-1.97)} (U - 0.08) + \frac{0.91}{(20.05)} \frac{\Delta \log \text{CPI}_{-1} + \Delta \log \text{CPI}_{-2}}{2} \\ & + \frac{0.17}{(5.23)} \Delta \log \text{GWAI} + \frac{0.01}{(6.60)} \text{D881} - \frac{0.02}{(-9.77)} \text{D912}, \end{aligned} \quad (49)$$

where the numbers in parentheses are Newey-West corrected t statistics, the adjusted R squared is 0.83, and the average quadratic error is 0.60 percent. The LM serial correlation test (with 4 lags) resulted in $F = 0.682$ (with a p value of 0.607); the Jarque-Bera normality test resulted in $\chi^2 = 3.617$ (with a p value of 0.164); and the White heteroskedasticity test resulted in $N \cdot R^2 = 38.619$ (with a p value of 0.003). The estimation period is 1986:3 to 2001:3.

Finally, to describe the sectoral behavior of wages, we use the following calibration for private and public wages, respectively:

$$\Delta \log \text{PW} = \frac{\Delta \log W - 0.17 \Delta \log \text{GWAI}}{0.83} \quad \text{and} \quad (50)$$

$$\Delta \log \text{GW} = \Delta \log \text{GWAI}. \quad (51)$$

Underlying inflation

The long-term price equation describes the behavior of inflation within a price index that excludes regulated services, perishables, meat, and fish (INFCPI_{X1}). A cointegration equation ensures that the steady-state price level is equal to a margin over production costs. These correspond to the private unit labor cost (CLU), the cost of public services through a proxy that is public wages ($\log \text{GW}$), and the imported component of costs ($\log \text{CIMP}$). Margins evolve over time according to the behavior of costs and the inflation dynamic.

The (log of the) unit labor cost corresponds to the private wage (PW) divided by average labor productivity (Y/N) plus VAT.

$$\log \text{CLU} = \log \left(\frac{\text{PW}}{Y/N} \right) + \log \text{VAT}. \quad (52)$$

To construct the imported component of costs we add together the logarithm of the external price index ($\log \text{EXPI}$), the log of the nominal exchange rate ($\log \text{NER}$), the logarithm of one plus the VAT ($\log \text{VAT}$), and the logarithm of one plus the tariff ($\log \text{TAR}$).

$$\log \text{CIMP} = \log \text{EXPI} + \log \text{NER} + \log \text{VAT} + \log \text{TAR}. \quad (53)$$

The change in inflation depends on lags of the output gap (GAP) and terms describing the dynamics. We also considered the role of expectations, including those regarding inflation for the following period, E (INFCPIX1). This was estimated using a limited-information method. The instruments used to estimate expected inflation were lags in the variable itself, the output gap, inflation targeting, unemployment, productivity, public and private

wages, the exchange rate, and oil price growth. A term for lagged inflation was also included.

$$\begin{aligned}
 \Delta \text{INFCPI}_{X1} = & 0.52 + 0.58 E(\Delta \text{INFCPI}_{X1})_{+1} + 0.09 \text{GAP} - 0.18 \log \text{CPI}_{X1-1} \\
 & \quad (2.68) \quad (4.51) \quad (2.03) \quad (-4.93) \\
 & + 0.13 \log \text{CLU}_{-1} + 0.04 \log \text{GW}_{-1} + 0.02 \log \text{CIMP}_{-1} - 0.33 \text{INFCPI}_{X1-1} \\
 & \quad (3.85) \quad (3.16) \quad (1.83) \quad (-2.26) \\
 & + 0.13 \log \text{CLU} + 0.04 \log \text{CIMP} + 0.01 \text{D2} - 0.002 \text{D3}, \\
 & \quad (3.61) \quad (2.02) \quad (3.97) \quad (-1.03)
 \end{aligned} \tag{54}$$

where the numbers in parentheses are Newey-West corrected t statistics, the adjusted R squared is 0.78, and the average quadratic error is 0.45 percent. The LM serial correlation test (with 4 lags) resulted in $F = 1.311$ (with a p value of 0.281); the Jarque-Bera normality test resulted in $\chi^2 = 0.104$ (with a p value of 0.950); and the White heteroskedasticity test resulted in $N \cdot R^2 = 45.973$ (with a p value of 0.102). The estimation period is 1987:1 to 2001:3.

2.5 Deflators and Relative Prices

This section introduces deflators for the user cost of capital and durable goods and for aggregate demand and GDP. In the latter case, the deflators draw on the *Indices de Valor Unitario de las Importaciones y Exportaciones* (import unit value index, UVIM; export value index, UVIX) that are calculated and published by the Balance of Payments Department of the Central Bank of Chile. The import index is calculated for each component: imports of consumption goods (UVIM_C), capital goods (UVIM_K), and intermediate fuel (UVIM_{FL}) and nonfuel (UVIM_{NFL}) goods. For exports, the calculation is performed for the exports of principal goods (UVIX_{PRINC}) and other exports (UVIX_{OTHER}).

The price indices mentioned above are Paasche indices, while volume indices are Laspeyres indices. Price indices are such that when multiplied by the quantity index, the result is the export value (or an index of the same).²⁶ Unit value indices are consistent with price assumptions for the main export and import goods and inflation assumptions for the most important foreign economies and their exchange rates. This forecast is exogenous to the other model forecasts.

The financial servicing of foreign accounts consists mainly of net interest payments on short-, medium-, and long-term public and private debt, interest received on foreign exchange reserves, and profits on investment from abroad and located abroad. Overall, we can calculate an implicit interest rate for net international assets (RIA). To make assumptions about the future accrual of profits and interest payments, the Central Bank's Balance of Payments Department develops a forecast using this implicit interest rate.

26. For more detail, see Meza and Pizarro (1982).

The user cost of capital and durable goods

The user cost of capital is calculated separately for machinery (CK_{MACH}) and construction (CK_{CONSTR}).²⁷ For machinery the user cost of capital is

$$CK_{MACH} = TAF_{MACH} (MORT + DEP_{MACH}) \frac{PGFK_{MACH}}{P}, \quad (55)$$

where TAF_{MACH} is a tax adjustment factor, $MORT$ is the interest rate on mortgages, DEP_{MACH} is the depreciation rate for capital in machinery, $PGFK_{MACH}$ is the deflator of capital in machinery, and P is the deflator of gross domestic product. The tax adjustment factor is expressed as

$$TAF_{MACH} = (1 - 0.6TUT + DEP_{MACH}) \frac{1 + TAR}{(1 - VAT)(1 - TUT)}, \quad (56)$$

where TUT is the tax rate on company profits, TAR is the customs tariff, and VAT is the value added tax. Likewise, for the case of construction, the user cost of capital is expressed as

$$CK_{CONSTR} = TAF_{CONSTR} (MORT + DEP_{CONSTR}) \frac{PGFK_{CONSTR}}{P}, \quad (57)$$

where the tax adjustment factor is expressed as

$$TAF_{CONSTR} = (1 - 0.6IT + DEP_{CONSTR}) \frac{1 + TAR}{(1 - VAT)(1 - IT)}. \quad (58)$$

For the user cost of durable goods (CK_D), the following equation is used:²⁸

$$CK_D = \left(\frac{CPI_D}{CPI_H} \right) \left(\frac{PRC8 - DEP_D}{1 + PRC8} \right). \quad (59)$$

This calculation indicates that the cost is a rising function of the interest rate ($PRC8$), the price of durable goods over nondurable consumption goods (CPI_D/CPI_H), and an inverse function of the depreciation rate for these goods. The durable and nondurable goods CPI is calculated by selecting the corresponding products from the CPI basket of the National Statistical Institute (INE).²⁹

Deflators for aggregate demand and GDP

In the case of expenditure on consumption goods, it is assumed that the relevant deflator (PPC) moves according to changes in the CPI:

27. The capital cost calculation is based on work by Bustos, Engel, and Galetovic (2000).

28. For details on how to obtain and motivate this cost, see Obstfeld and Rogoff (1996).

29. For more detail, see Gallego and Soto (2000).

$$\Delta \log \text{PPC} = \Delta \log \text{CPI} . \quad (60)$$

With regard to investment, we distinguish between the deflator for gross formation in machinery ($\text{PGFK}_{\text{MACH}}$), the deflator for gross formation in construction ($\text{PGFK}_{\text{CONSTR}}$), and the deflator for investment in inventory (PIINV). The first moves according to the price of capital goods imports, because about half of this kind of investment is in goods from abroad. Moreover, we assume that because of the law of one price, the even price of these goods of domestic origin should not deviate much from the price of imported goods. The equation is therefore expressed as

$$\Delta \log \text{PGFK}_{\text{MACH}} = \Delta \log \text{UVIM}_K + \Delta \log \text{NER} . \quad (61)$$

For construction, costs are primarily of domestic origin. Changes in the deflator thus correspond to a weighted average of changes in labor costs and the CPI_{X1} :

$$\Delta \log \text{PGFK}_{\text{CONSTR}} = \phi_{\text{PGFK}_{\text{CONSTR}}} \Delta \log \text{CL} + (1 - \phi_{\text{PGFK}_{\text{CONSTR}}}) \Delta \log \text{CPI}_{\text{X1}} . \quad (62)$$

The deflator of inventory investment is associated with import prices. As mentioned above, an important part of these inventories is imported. Changes in this deflator are therefore expressed as

$$\Delta \log \text{PIINV} = \Delta \log \text{UVIM} + \Delta \log \text{NER} . \quad (63)$$

For the deflator of government expenditure on consumption, we assume that

$$\Delta \log \text{PGC} = \phi_{\text{PGC}} \Delta \log \text{GW} + (1 - \phi_{\text{PGC}}) \Delta \log \text{CPI}_{\text{X1}} . \quad (64)$$

The deflator of imports of goods (PMG) is expressed as the conversion of the unit value index, expressed in constant 1986 dollars:

$$\log \text{PMG} = \log \text{UVIM} + \log \text{NER} - \log \text{NER86} + \phi_{\text{PMG}} , \quad (65)$$

where NER86 denotes the average nominal exchange rate in 1986 and a constant is included to adjust the base year. The deflator for imports of services, which is necessary to convert constant pesos to current dollars, is assumed to depend on the nominal exchange rate and external prices, and it includes a constant to adjust the base year:

$$\log \text{PMS} = \log \text{EXPI}_{\text{MS}} + \log \text{NER} - \log \text{NER86} + \phi_{\text{PMS}} . \quad (66)$$

The deflator of exports has a similar treatment. Thus, the deflator of the export of goods (PXG) is expressed as

$$\log \text{PXG} = \log \text{UVIX} + \log \text{NER} - \log \text{NER86} + \phi_{\text{PXG}} . \quad (67)$$

Likewise, the deflator of the exports of nonfinancial services is expressed as

$$\log \text{PXS} = \log \text{EXPI}_{\text{XS}} + \log \text{NER} - \log \text{NER86} + \phi_{\text{PXS}} . \quad (68)$$

The GDP deflator is the one used to compare nominal figures in current pesos to real figures in constant pesos. Therefore, the GDP deflator is simply the result of dividing nominal GDP by real GDP, expressed as follows:

$$P = \frac{PPC \cdot PC + PI \cdot I + PGC \cdot GC + PX \cdot X + PM \cdot M}{PC + I + GC + X + M}, \quad (69)$$

where

$$PI \cdot I = PGFK_{MACH} \cdot GFK_{MACH} + PGFK_{CONSTR} \cdot GFK_{CONSTR} + PIINV \cdot IINV, \quad (70)$$

$$PX \cdot X = PXG \cdot XG + PXS \cdot XS, \text{ and} \quad (71)$$

$$PM \cdot M = PMG \cdot MG + PMS \cdot MS, \quad (72)$$

3. IMPULSE RESPONSES (MEP2)

In this section we look at the response of a number of key macroeconomic variables to temporary and permanent shocks to the monetary policy interest rate. We contrast the results from the MEP2 with the response to the same shock under the MEP1 and a VAR model of the economy.³⁰

3.1 Temporary Shock and Robustness of the Model

This section examines the response of key macroeconomic variables to a temporary shock (one quarter) to the monetary policy interest rate under the three different models described above. In particular, we look at the response of inflation, GDP, and the real exchange rate. We also compare the evolution of the monetary policy rate after the shock. Even though the shock is temporary, the trajectory of the monetary policy rate after the first period depends on the response of the monetary authority to the conditions in the economy. All responses are depicted in figure 11.

[figure 11 about here]

The six graphs in the figure show that the main variables of the different models behave in a fairly similar fashion. The monetary policy rate rises in all cases by 100 basis points and drops back to stay around the initial level after two to three quarters. The first panel shows that in response to the change in the monetary policy rate, the minimum value for the inflation rate is about 0.20 percentage points below the initial level, according to the MEP2. This value is about 0.05 percentage points larger for the MEP2 than for the MEP1 and about 0.10 percentage points larger than for the VAR. The minimum inflation (maximum deflation) occurs after seven quarters according to the MEP2, after eight quarters according to the MEP1, and after six quarters according to the VAR. The VAR shows an initial inflationary period that is, however, not significantly different from zero (confidence bands are not shown to keep the picture clear). According to both the MEP1 and the MEP2, inflation drops initially by 0.05 percentage points and smoothly converges to the minimum point. Convergence to the long-run equilibrium is smoother according to the MEP1 and the MEP2 than to the VAR.

With respect to GDP, all three models show a contractionary effect in the very first quarters after the change in the monetary policy rate. The minimum

30. The VAR model is described in Bravo and García (2002).

GDP gap occurs earlier under the MEP2 (in the first quarter after the shock) than under either the MEP1 or the VAR. The GDP gap reaches a minimum of about -0.6 percent based on the MEP2, which is slightly less than the -0.4 percent implied by the MEP1 and considerably larger than the -1.1 percent implied by the VAR. All three models show a relatively smooth recovery of the growth output gap, and the gap closes for all three model around the same date.

The real exchange rate dynamics are also reasonably similar for the three models, although the VAR model shows some differences. All three models show an initial real appreciation that ranges from 0.4 percent for the VAR (with a subsequent appreciation reaching a real appreciation of 0.8 percent in the second quarter) to 1.3 percent for the MEP1, with the MEP2 showing an intermediate result of a 1.0 percent real appreciation. Both the MEP1 and the MEP2 exhibit a subsequent depreciation and then a convergence to the initial level. The VAR shows a very mild appreciation relative to the initial level (not significantly different from zero).

An advantage of the MEP2 over both the MEP1 and the VAR presented above is that it allows us to calculate the current account of the balance of payments. The fifth panel in figure 11 shows the response of the current account as a percentage of GDP to the 100 basis point temporary shock to the monetary policy rate. Initially, the current account deteriorates, reaching a mild deficit of -0.3 percent in response to the initial appreciation of the real exchange rate. The current account is already on the surplus side by the third quarter. The surplus is due to both the depreciation of the real exchange rate and the fall in GDP. The maximum surplus of almost 1 percent of GDP is achieved after five quarters. The current account drops back to the initial level after seven quarters. The rise of the monetary policy rate induces a current account surplus that takes off after three quarters, reaches its maximum (of 1 percent of GDP) after five quarters, and lasts for about seven quarters.

3.2 Permanent Shock

An important advantage of the MEP2 over a simple gap model, such as the MEP1, is that the steady state is well defined. This allows us to investigate the effects of permanent shocks both in the short- to middle-run dynamics and in the long-run impact. Figure 12 shows the response of a number of key variables to a permanent increase of 5 percentage points in the ratio of government spending to GDP. This shock to aggregate demand translates into an increase in GDP of 6 percent. GDP increases by more than government spending because of an effect on investment and consumption. Both these variables are procyclical in the short run. The real exchange rate, in anticipation of the rise in domestic interest rates, tends to appreciate by about 6.5 percent. The appreciation and the increase in GDP together induce a current account deficit that rises from 3 percent of GDP in the quarter of the shock to almost 10 percent of GDP a quarter later. Inflation builds up slowly in response to the increased output gap and reaches a maximum of about 1 percent five quarters after the shock.

[figure 12 about here]

The monetary policy rate increases considerably only a quarter after the shock, in response to the increased output, the rise in inflation and future inflation, and the increase in the foreign spread, all of which affect expected inflation. A drop in GDP, a drop in inflation, and a recovery of the real exchange rate and the current account follow the increase in the monetary policy rate. In particular, GDP drops back toward its initial level, and it is less than 1 percent above the initial level within about seven quarters. Inflation enters into a mild but persistent deflationary period after the eighth quarter. The current account deficit tends to close,

following a short surplus period. The real exchange rate remains appreciated by 3 percent relative to the initial level, and the monetary policy rate remains above the initial steady-state level by 20 basis points.

The price of copper is a critical variable, given the commodity's importance in Chilean production and exports. Figure 13 presents the response of key variables to a permanent drop of 20 percent in the price of this commodity. The current account deteriorates with the drop in the price of copper, reaching a deficit of about 4.5 percent of GDP. This deficit reflects the importance of copper in total Chilean exports. The deterioration of the trade balance also translates into a fall of GDP of 1.1 percent. An initial increase in the real exchange rate (7.5 percent), inflation (0.5 percent), and the foreign spread induce an increase in the monetary policy rate of 20 basis points, despite the initial negative output gap. The increase in interest rates and the depreciation of the real exchange rate imply higher costs of investment, particularly investment in machinery that has an important imported component. This cost increase reduces both investment and potential output in the long run. This, in turn, will lower GDP in the long run. Inflation tends to drop back to the target level, and the monetary policy rate falls with inflation to become expansionary rather than contractionary after five quarters. The real exchange rate remains appreciated by about 8 percent in the long run with respect to the initial level.

[figure 13 about here]

The price of oil is also important for the Chilean economy, as oil is an important component of Chilean imports. A permanent increase of 20 percent in this price has effects that are very similar, at least qualitatively, to the impact of an increase in the price of copper. Fluctuations in all variables are smaller for the case of the shock to the price of oil (see figure 14).

[figure 14 about here]

A final exercise we present here is a permanent increase of 100 basis point in the relevant foreign interest rate. Results are presented in figure 15. This increase has two immediate effects: namely, to raise the monetary policy rate and the real exchange rate. Both these effects operate to reduce GDP. Inflation tends to increase first and drops later owing to the negative GDP growth and the rise in the monetary policy rate. Output tends to return to its initial level in the long run, but it remains slightly below that level. Inflation converges slowly to the target level. The current account remains in surplus, inducing a drop in the foreign spread that partially compensates for the higher foreign interest rates, while the real exchange rate remains appreciated by about 1 percent relative to the initial steady-state level.

[figure 15 about here]

REFERENCES

- Agénor, P.-R. 2002. "Monetary Policy under Flexible Exchange Rates: An Introduction to Inflation Targeting." In *Inflation Targeting: Design, Performance, Challenges*, edited by N. Loayza and R. Soto, 79-170. Santiago: Central Bank of Chile.
- Belaisch, A., and R. Soto. 1998. "Empirical Regularities of Chilean Business Cycles." Working paper 41. Santiago: Central Bank of Chile.
- Bernanke, B., M. Gertler, and S. Gilchrist. 1996. "The Financial Accelerator and the Flight to Quality." *Review of Economics and Statistics* 78(1): 1-15.
- Blanchard, O. J. 1984. "The Lucas Critique and the Volcker Deflation." Working paper 1326. Cambridge, Mass.: National Bureau of Economic Research.
- Blanchard, O. J., and S. Fischer. 1989. *Lectures on Macroeconomics*. Cambridge, Mass.: MIT Press.
- Bravo, H. F., and H. Franken, 2002. "Un indicador líder del IMACEC." *Revista de Análisis Económico* 17(1): 103-23. ILADES/Georgetown University.
- Bravo, H. F., and C. J. García. 2002. "Medición de la política monetaria y el coeficiente de traspaso (pass-through) en Chile," *Economía Chilena* 5(3): 5-28.
- Bravo, H. F., and J. E. Restrepo. 2001. "Funciones de inversión para proyecciones macroeconómicas." Santiago: Central Bank of Chile, Gerencia de Análisis Macroeconómico.
- Bustos, A., E. Engel, and A. Galetovic. 2000. "Impuestos y demanda por capital: teoría y evidencia para Chile." Economía series 94. Universidad de Chile, Departamento de Ingeniería Industrial.
- Campbell, J. Y., A. W. Lo, and A. C. McKinlay. 1997. "The Econometrics of Financial Markets." Princeton University Press.
- Campbell, J. Y., and N. G. Mankiw. 1989. "Consumption, Income, and Interest Rates: Reinterpreting the Time Series Evidence." Working paper 2924. Cambridge, Mass.: National Bureau of Economic Research.
- Clarida, R., J. Galí, and M. Gertler. 1999. "The Science of Monetary Policy: A New Keynesian Perspective." *Journal of Economic Literature* 37 (December): 1661-707.
- Contreras, G., and P. García. 2002. "Estimating Gaps and Trends for the Chilean Economy." In *The Challenges of Economic Growth*, edited by N. Loayza and R. Soto. Santiago: Central Bank of Chile.
- Engel, C. 1995. "The Forward Discount Anomaly and the Risk Premium: A Survey of Recent Evidence." Working paper 5312. Cambridge, Mass.: National Bureau of Economic Research.
- Feliú, C. 1992. "Inflación externa y tipo de cambio real: nota metodológica." Economic studies research paper 37. Santiago: Central Bank of Chile.
- Flood, R. P., and M. P. Taylor. 1996. "Exchange Rate Economics: What's Wrong with the Conventional Macro Approach?" In *The Microstructure of Foreign Exchange Markets*, edited by J. A. Frankel, G. Galli, and A. Giovannini, 261-94. *National Bureau of Economic Research Conference Report* series. University of Chicago Press.
- Gallego, F., and R. Soto. 2000. "Evolución del consumo y compras de bienes durables en Chile, 1981-1999." Working paper 79. Santiago: Central Bank of Chile.
- García, C., and G. Contreras. 2001. "Desempleo y participación laboral." Santiago: Central Bank of Chile. Mimeographed.
- García, P., L.O. Herrera, and R. Valdés. 2002. "New Frontiers for Monetary Policy in Chile." In *Inflation Targeting: Design, Performance, Challenges*, edited by N. Loayza and R. Soto, 627-649. Santiago: Central Bank of Chile.

- Herrera, L. O., and I. Magendzo. 1997. "Expectativas financieras y la curva de tasas forward de Chile." Working paper 23. Santiago: Central Bank of Chile.
- Herrera, L. O., and F. Rosende. 1991. "Teoría y política monetaria: elementos para el análisis." *Cuadernos de Economía* 28(83): 55-93.
- Isard, P. 1995. *Exchange Rate Economics. Surveys of Economic Literature* series. Cambridge University Press.
- Lewis, K. K. 1994. "Puzzles in International Financial Markets." Working paper 4951. Cambridge, Mass.: National Bureau of Economic Research.
- MacDonald, R., and M. P. Taylor. 1992. "Exchange Rate Economics: A Survey." *IMF Staff Papers* 39(1): 1-57.
- Medina, J. P., and R. Valdés. 2002a. "Optimal Monetary Policy under Inflation Range Targeting." In *Monetary Policy: Rules and Transmission Mechanisms*, edited by N. Loayza and K. Schmidt-Hebbel, 95-116. Santiago: Central Bank of Chile.
- . 2002b. "Optimal Monetary Policy when the Current Account Matters." In *Monetary Policy: Rules and Transmission Mechanisms*, edited by N. Loayza and K. Schmidt-Hebbel, 65-94. Santiago: Central Bank of Chile.
- Meza, W., and F. Pizarro. 1982. "Números índices de comercio exterior: metodología utilizada para la elaboración de los índices de valor unitario y quantum de importaciones y exportaciones." Economic studies research paper 11. Santiago: Central Bank of Chile.
- Mies, V., and R. Soto. 2000. "Demanda por dinero: teoría, evidencia, resultados." *Economía Chilena* 3(2): 5-32.
- Morandé, F. 2002. "A Decade of Inflation Targeting in Chile: Developments, Lessons, Challenges." In *Inflation Targeting: Design, Performance, Challenges*, edited by N. Loayza and R. Soto, 583-626. Santiago: Central Bank of Chile.
- Obstfeld, M., and K. Rogoff. 1996. *Foundations of international macroeconomics*. MIT Press.
- Rojas, P. 1993. "El dinero como un objetivo intermedio de política monetaria en Chile: un análisis empírico." *Cuadernos de Economía* 30(90): 134-78.
- Svensson, L. E. O. 1997. "Inflation Forecast Targeting: Implementing and Monitoring Inflation Targets." *European Economic Review* 41 (June): 1111-46.
- Taylor, J. B. 1993. "Discretion versus Policy Rules in Practice." Carnegie-Rochester Conference Series on Public Policy 39 (December): 195-214.
- Woodford, M. 1999. "Optimal Monetary Policy Inertia." Working paper 7261. Cambridge, Mass.: National Bureau of Economic Research.

Figure 1. Labor Income as a Share of GDP

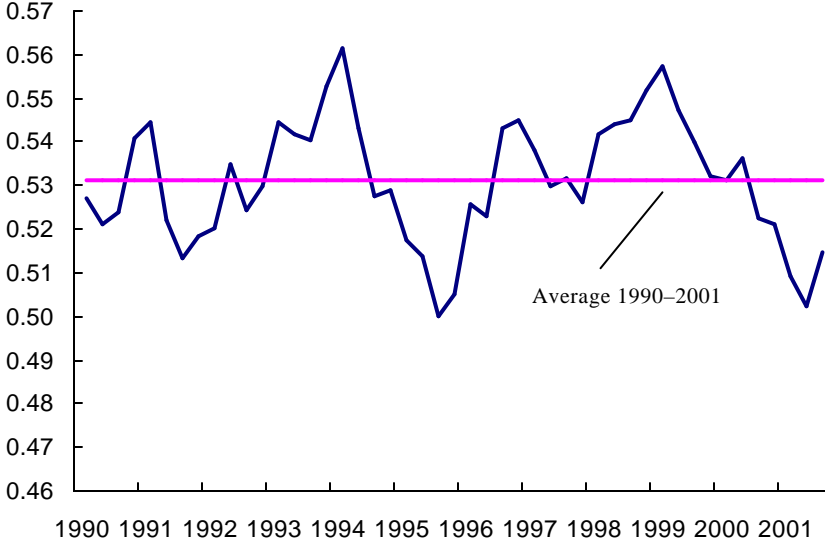

Figure 2. Economic Growth and External Conditions

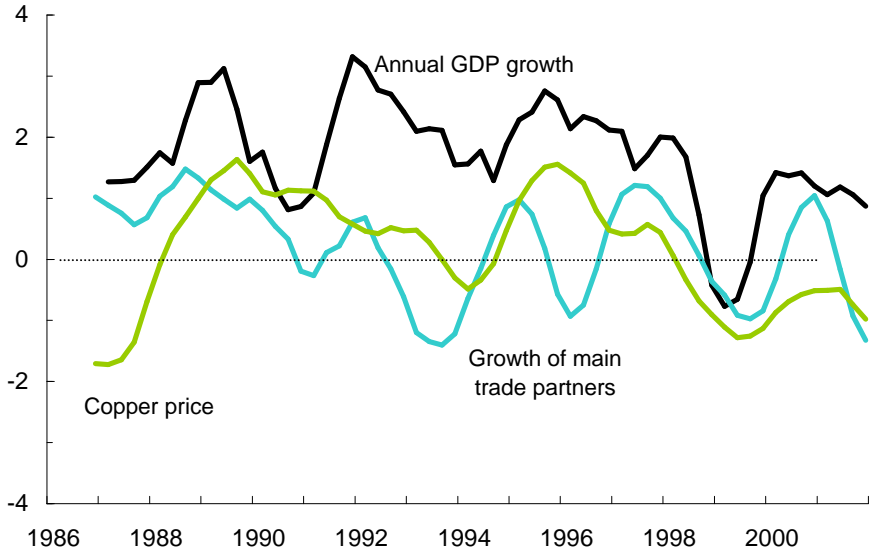

Figure 3. Annual Growth in Consumption and Unemployment

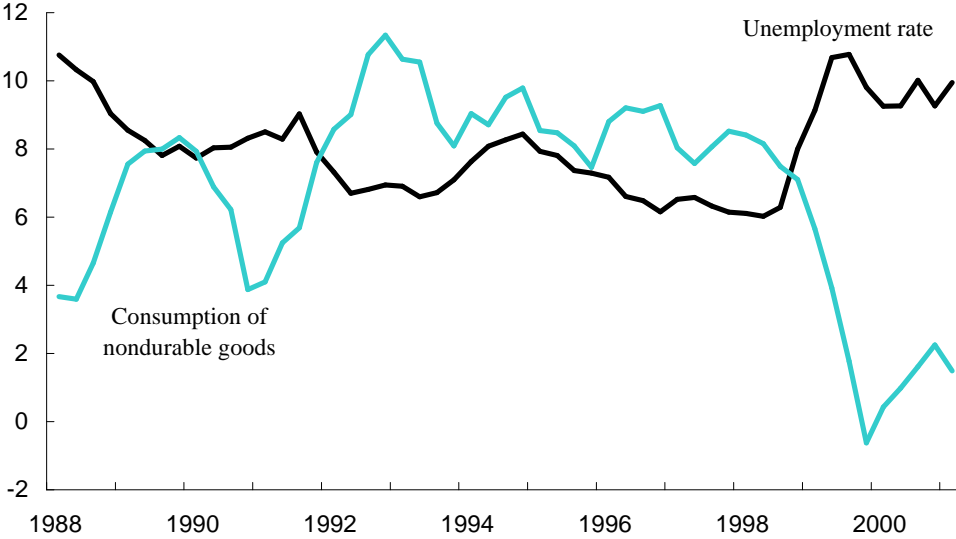

Figure 4. Imports and Domestic Expenditure

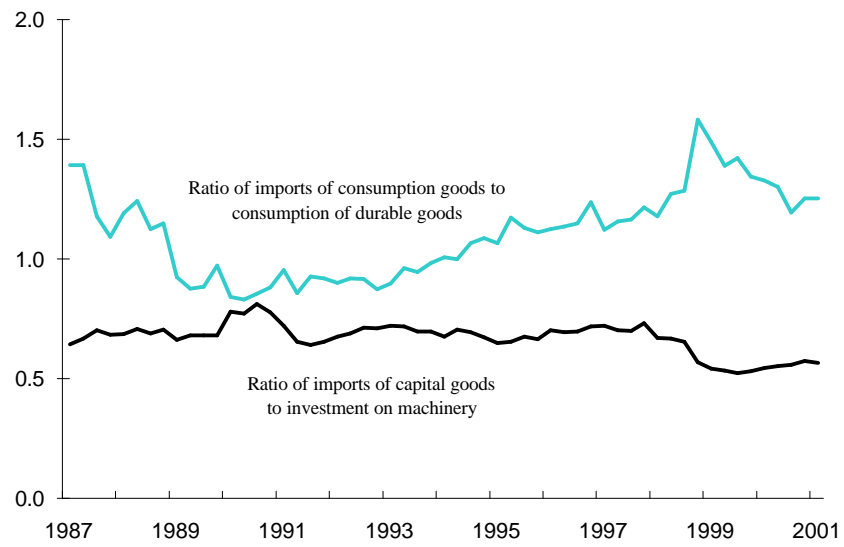
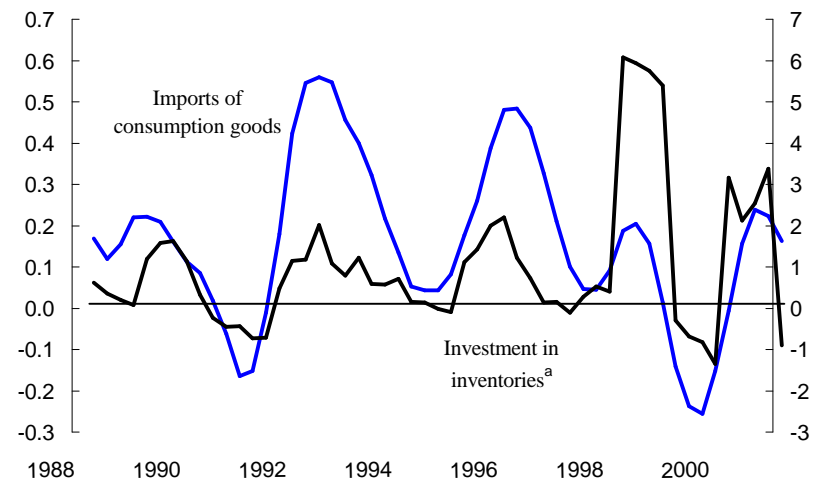
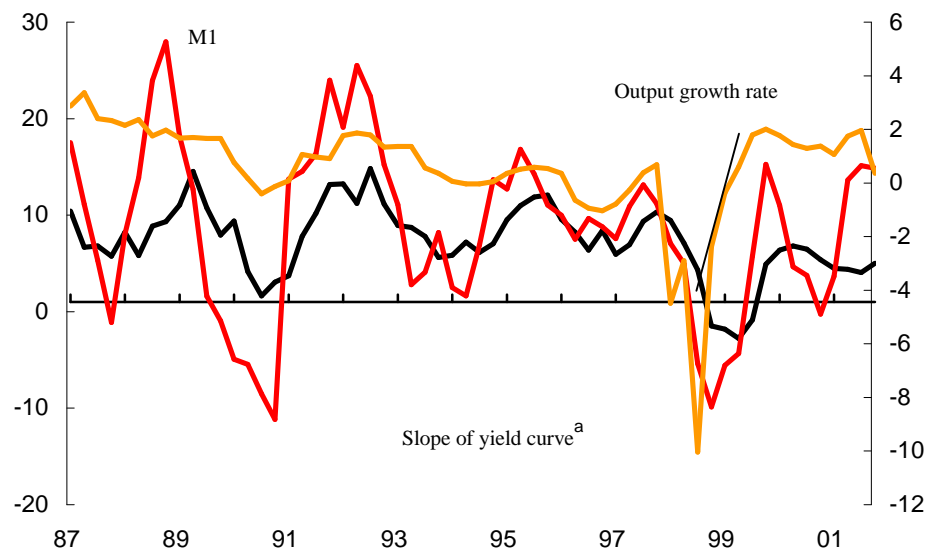

Figure 5. Imports and Inventories



a. Secondary y axis.

Figure 6. Annual GDP Growth and Financial Variables



a. Secondary y axis.

Figure 7. Determinants of the Cost of External Financing

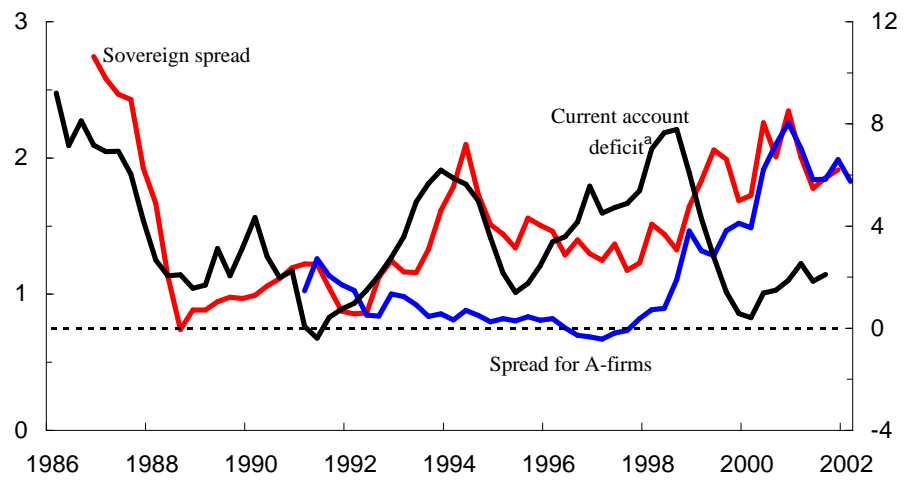

a. Secondary y axis.

Figure 8. Inflation and Inflation Target

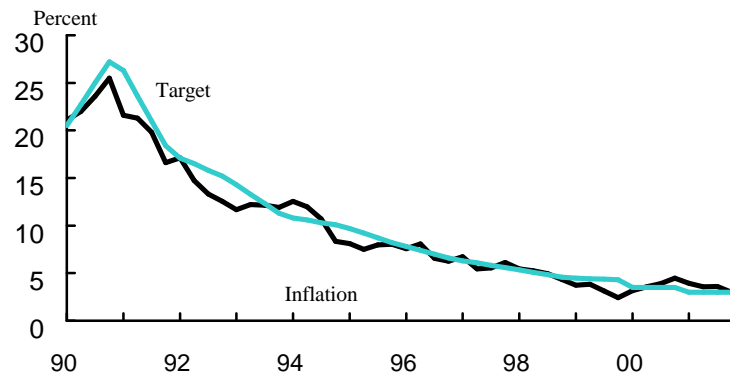
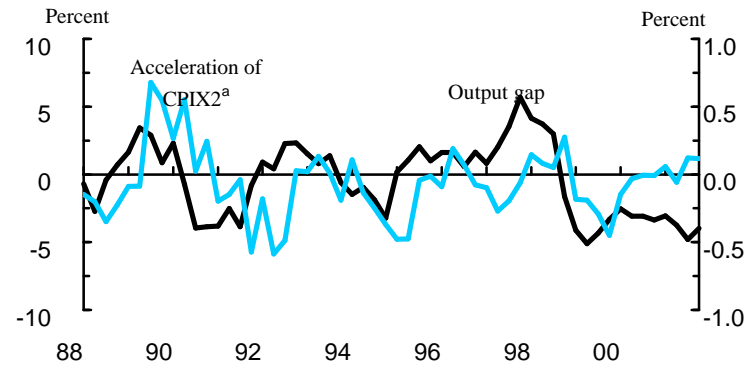
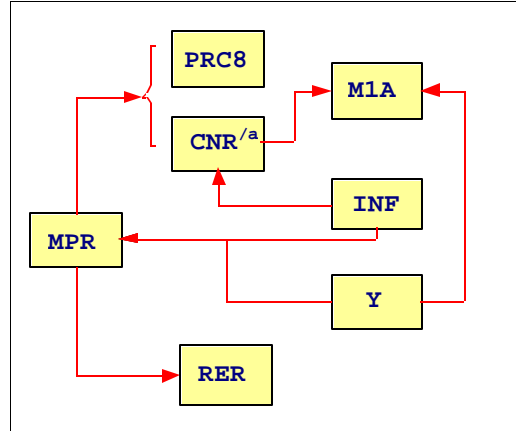

Figure 9. Inflation and the Output Gap



a. Secondary y axis.

Figure 10. Monetary Policy Transmission to Financial Markets



a. CNR is the medium-term nominal market interest rate.

Figure 11. Response to a Temporary Shock to the Monetary Policy Rate^a

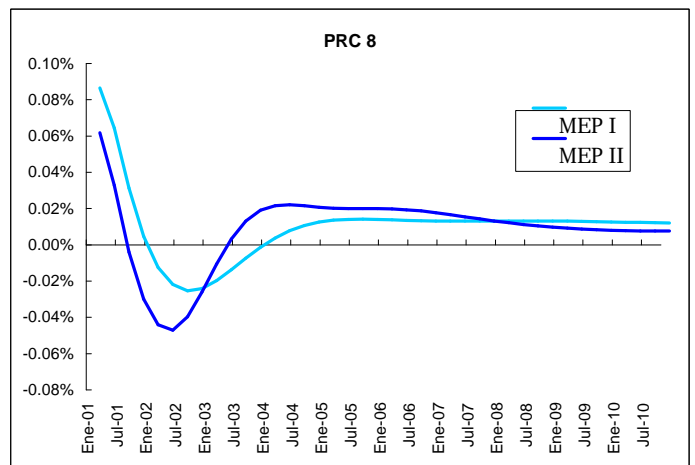
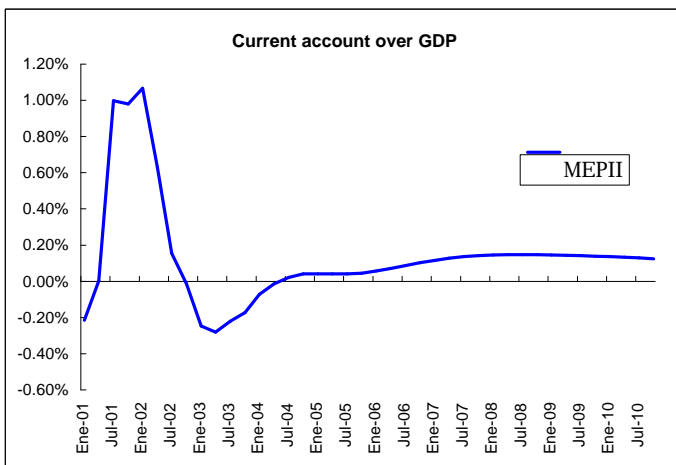
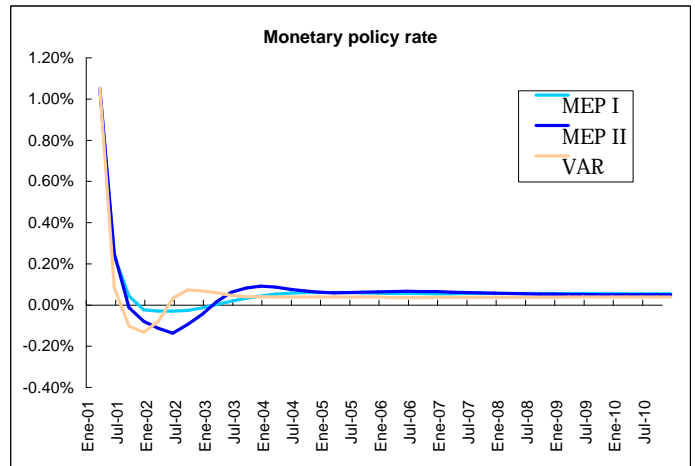
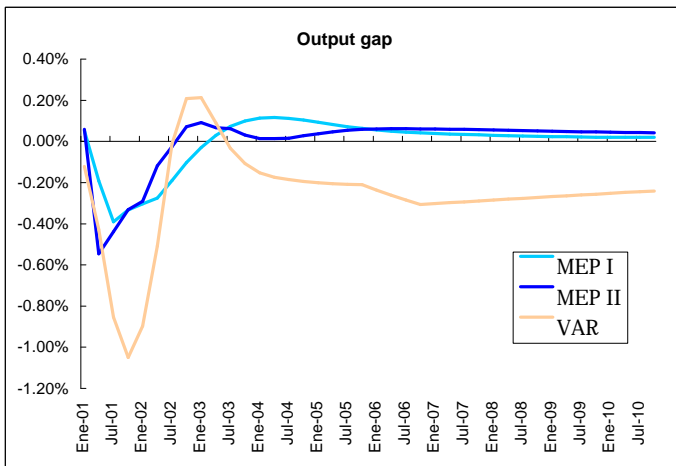
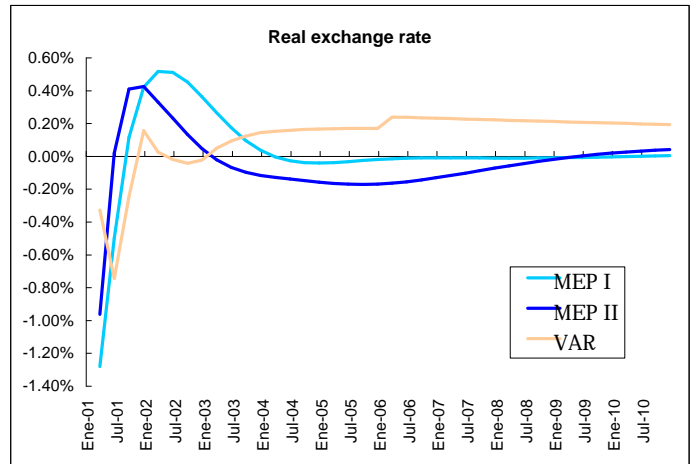
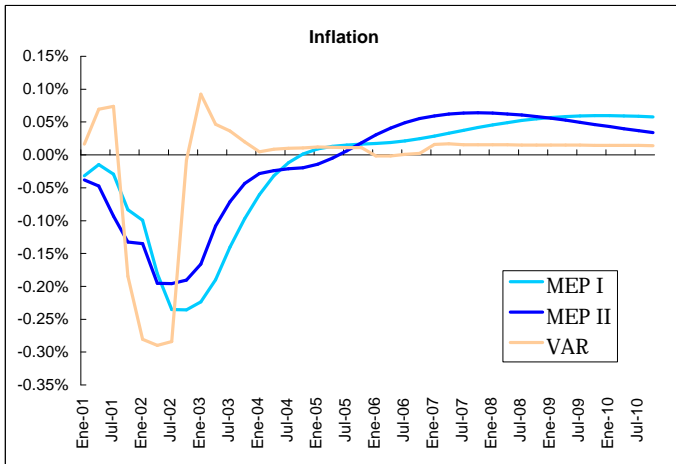

a. The shock is modeled as a 1 percentage point increase.

Figure 12. Response to a Permanent Shock to Government Spending^a

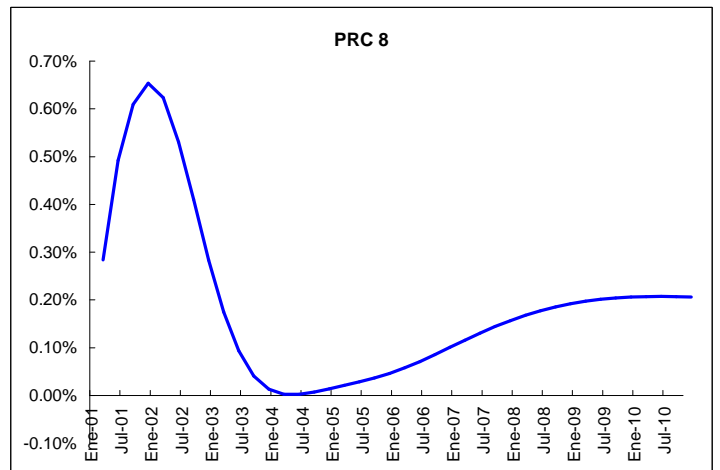
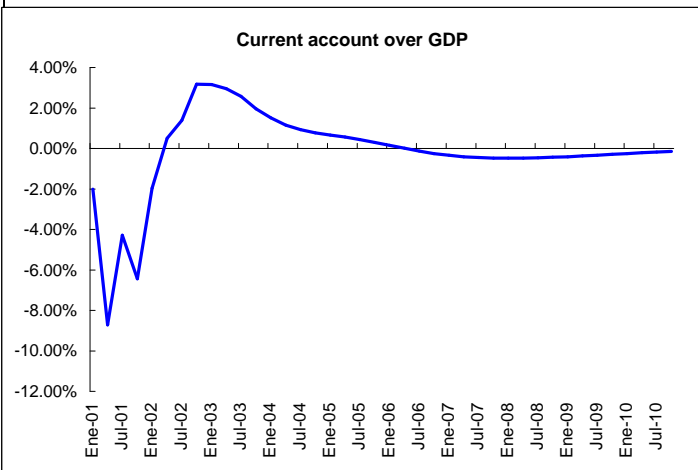
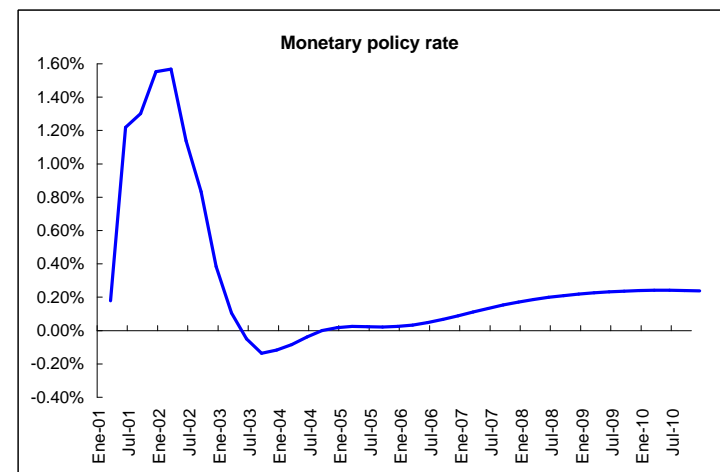
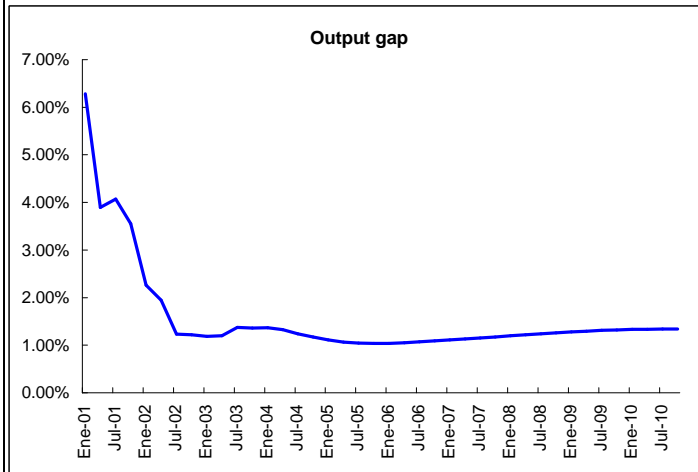
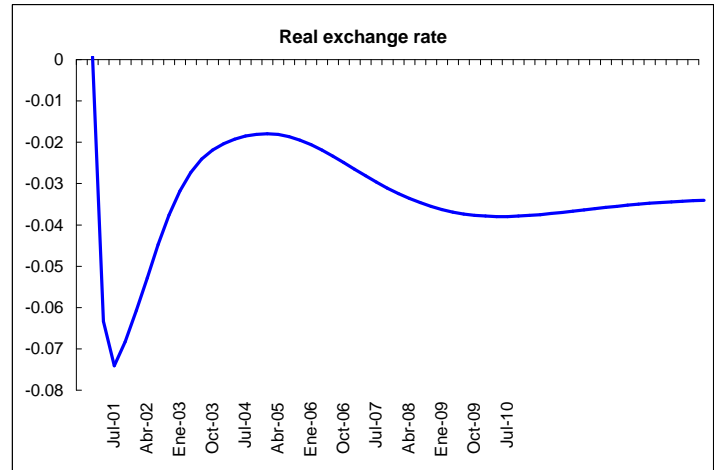
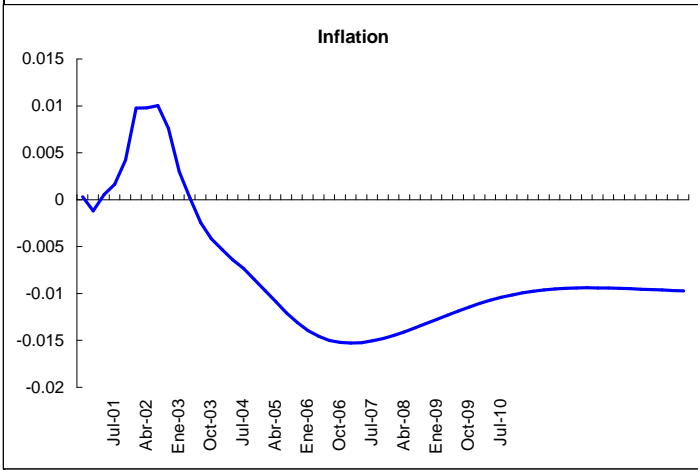

a. The shock is modeled as a 5 percentage point increase the ratio of government spending to GDP.

Figure 13. Response to a Permanent Shock to the Price of Copper

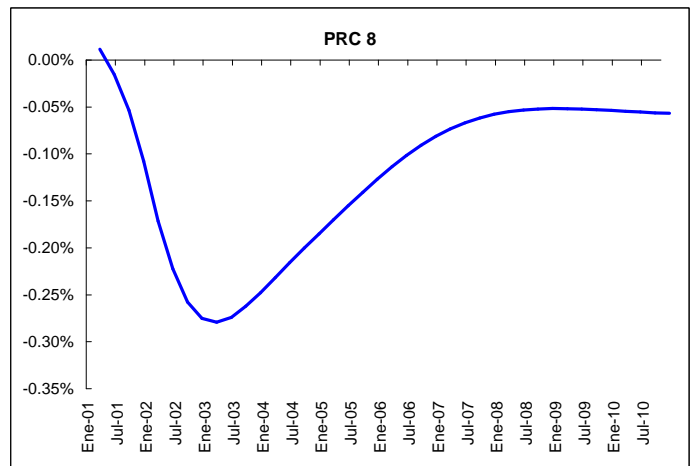
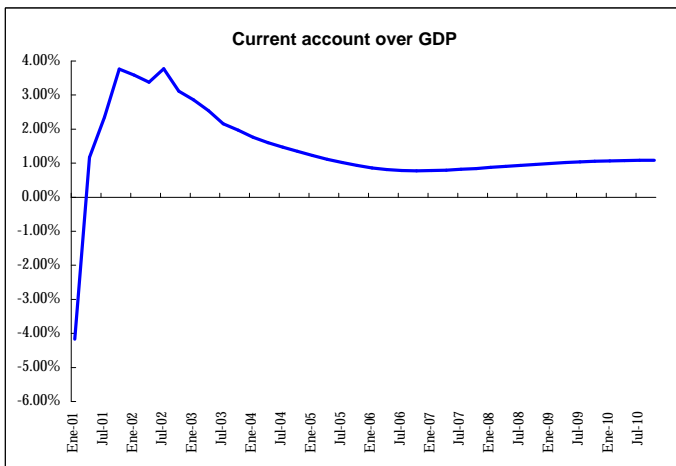
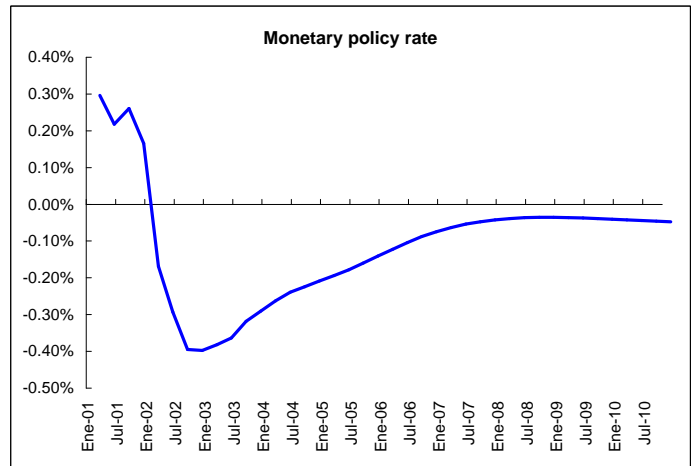
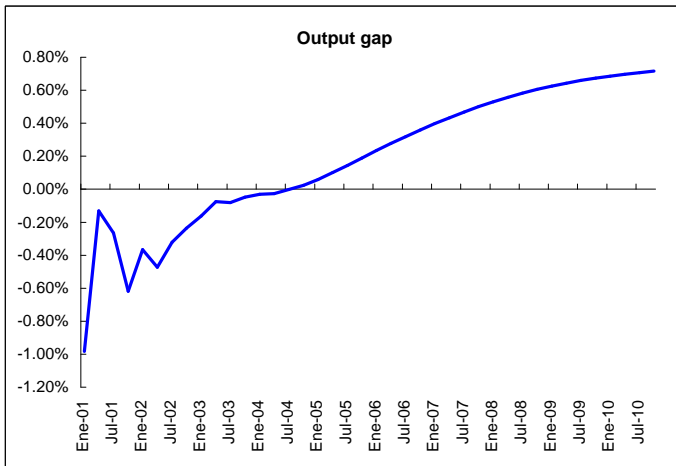
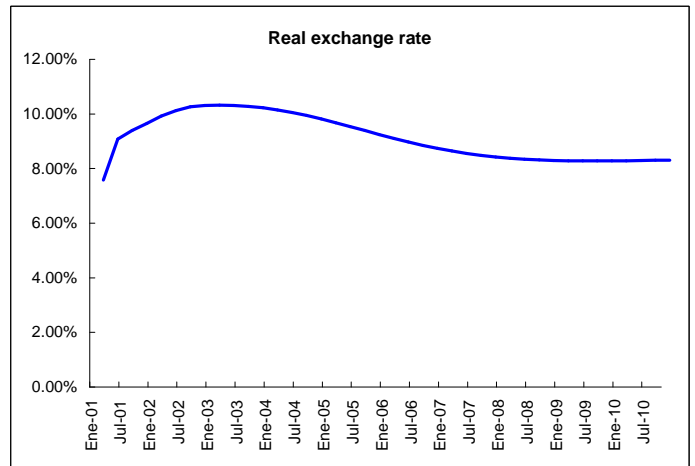
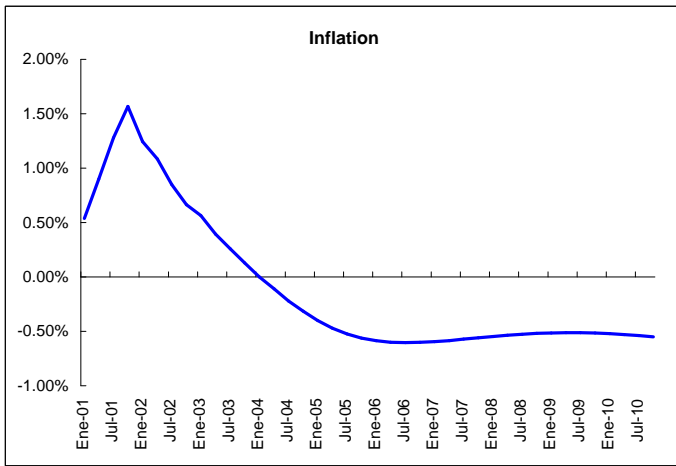

a. The shock is modeled as a 20 percent decrease in the price of copper.

Figure 14. Response to a Permanent Shock to the Price of Oil

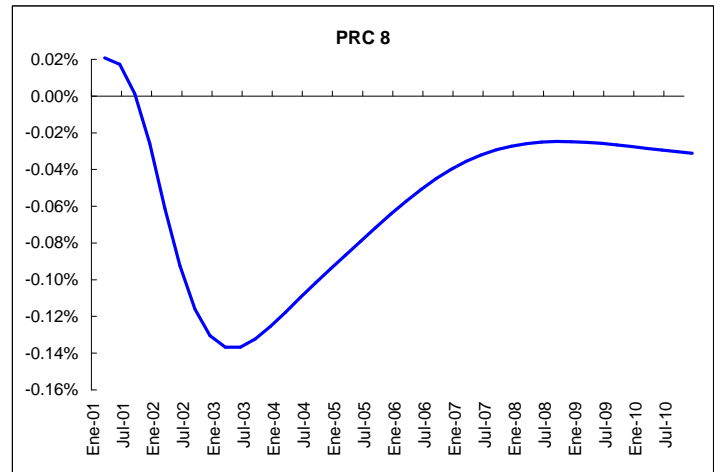
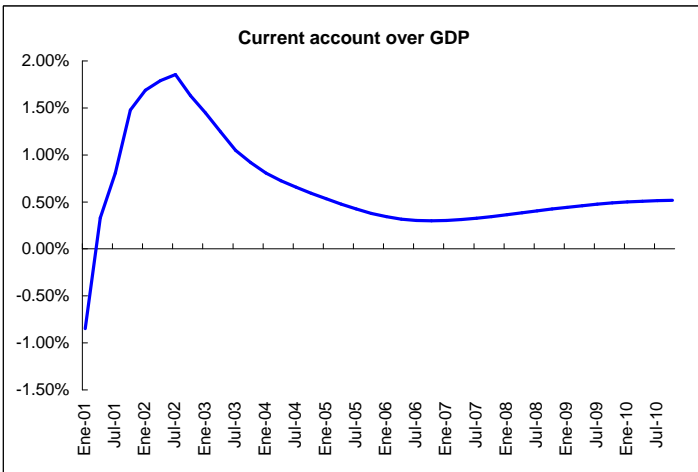
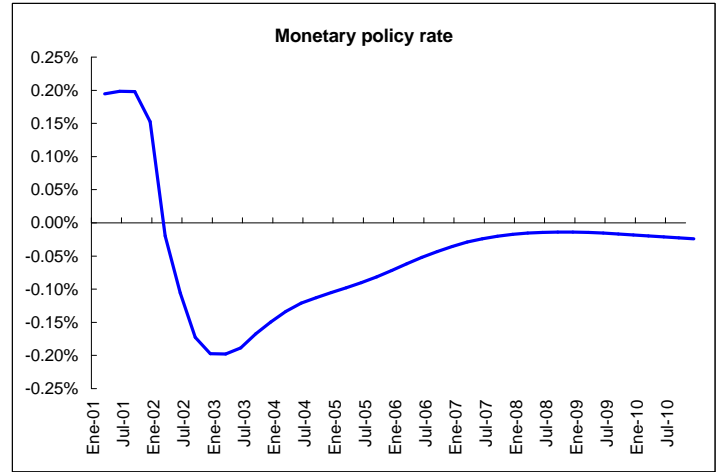
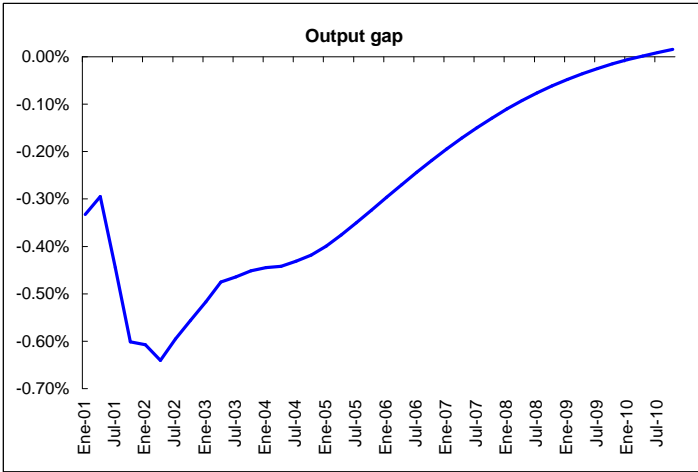
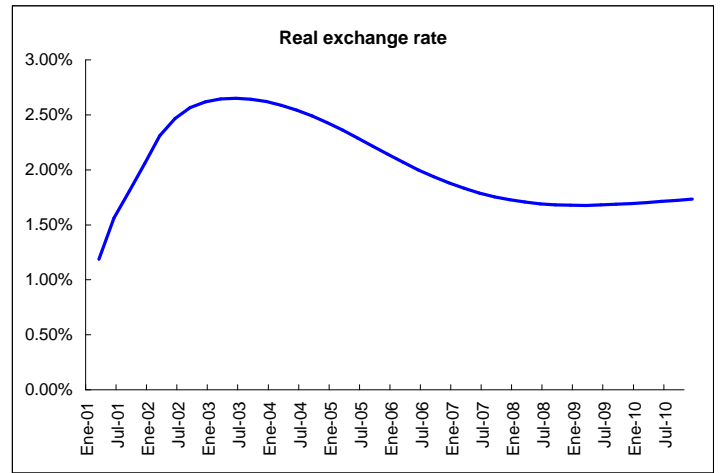
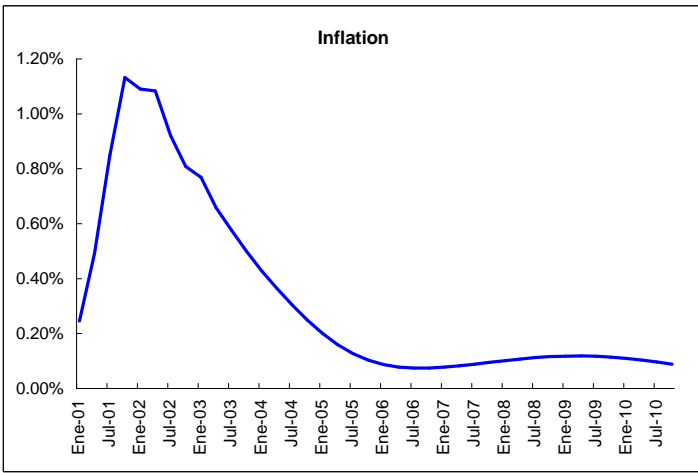

a. The shock is modeled as a 20 percent increase in the price of oil.

Figure 15. Response to a Permanent Shock to the International Interest Rate

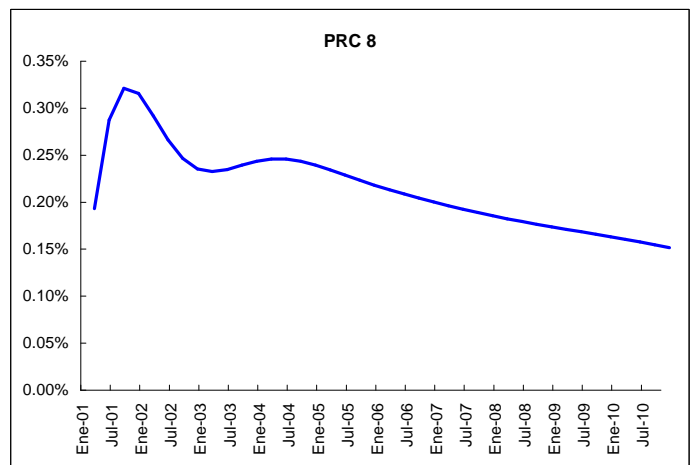
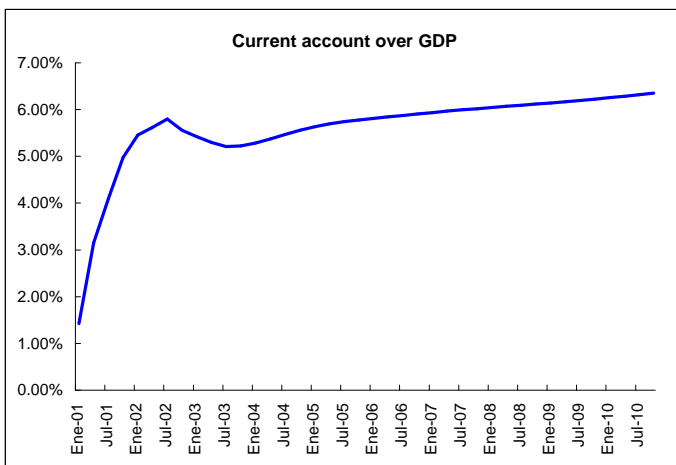
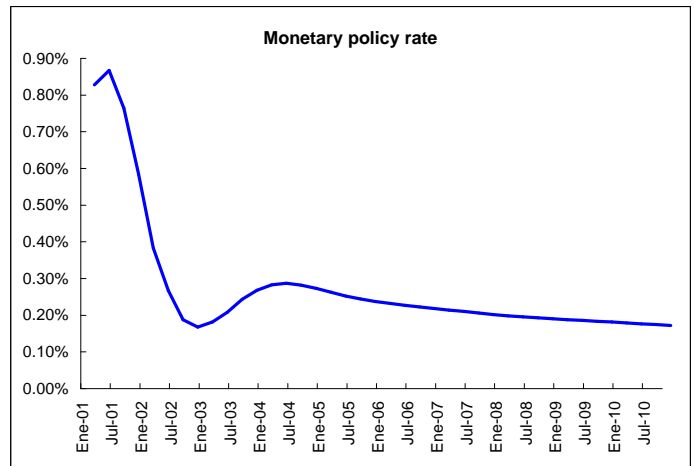
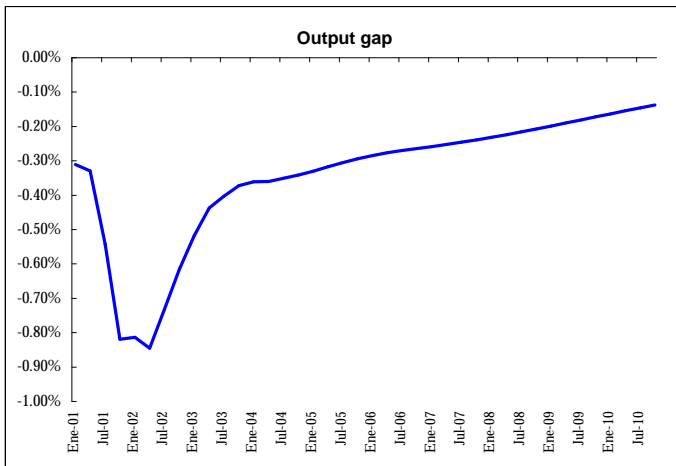
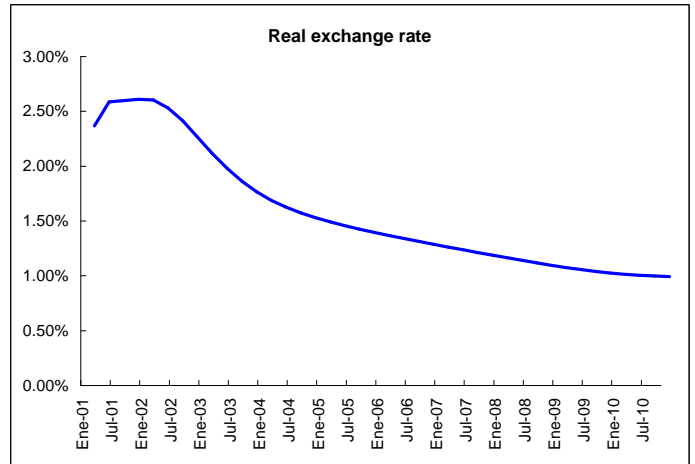
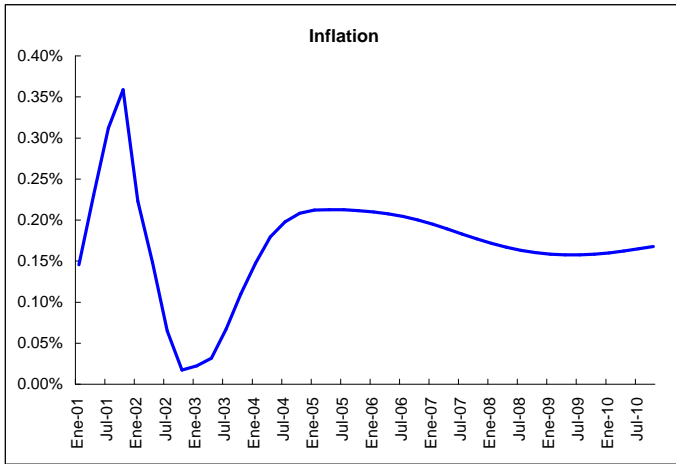

a. The shock is modeled as a 100 point increase in the rate.

**Documentos de Trabajo
Banco Central de Chile**

**Working Papers
Central Bank of Chile**

NÚMEROS ANTERIORES

PAST ISSUES

La serie de Documentos de Trabajo en versión PDF puede obtenerse gratis en la dirección electrónica: www.bcentral.cl/esp/estpub/estudios/dtbc. Existe la posibilidad de solicitar una copia impresa con un costo de \$500 si es dentro de Chile y US\$12 si es para fuera de Chile. Las solicitudes se pueden hacer por fax: (56-2) 6702231 o a través de correo electrónico: bcch@bcentral.cl.

Working Papers in PDF format can be downloaded free of charge from: www.bcentral.cl/eng/stdpub/studies/workingpaper. Printed versions can be ordered individually for US\$12 per copy (for orders inside Chile the charge is Ch\$500.) Orders can be placed by fax: (56-2) 6702231 or e-mail: bcch@bcentral.cl.

- | | |
|---|----------------|
| DTBC-253
Monetary Policy, Real Exchange Rate, and the Current Account
in a Small Open Economy
Claudio Soto | Diciembre 2003 |
| DTBC-252
Net Foreign Assets and Imperfect Financial Integration:
An Empirical Approach
Jorge Selaive y Vicente Tuesta | Diciembre 2003 |
| DTBC-251
Labor Market Distortions, Employment and Growth:
The Recent Chilean Experience
Raphael Bergoing, Felipe Morandé y Facundo Piguillem | Diciembre 2003 |
| DTBC-250
The Harberger-Laursen-Metzler Effect Revisited:
An Indirect-utility-function Approach
Roberto Duncan | Diciembre 2003 |
| DTBC-249
Floating, Official Dollarization, and Macroeconomic Volatility:
An Analysis for the Chilean Economy
Roberto Duncan | Diciembre 2003 |
| DTBC-248
Quantifying the Costs of Investment Limits for
Chilean Pension Funds
Solange M. Berstein y Rómulo A. Chumacero | Diciembre 2003 |

- DTBC-247
The ECOGEM-Chile Model: A CGE Model for Environmental and Trade Policy Analysis
Raúl O’Ryan, Carlos J. de Miguel y Sebastián Miller
Diciembre 2003
- DTBC-246
Productivity Growth and Disinflation in Chile
José De Gregorio
Diciembre 2003
- DTBC-245
Growth and Adjustment in East Asia and Latin America
José De Gregorio y Jong-Wha Lee
Diciembre 2003
- DTBC-244
On the Removal of Agricultural Price Bands in Chile: A General Equilibrium Analysis
David Holland, Eugenio Figueroa B., Roberto Alvarez y John Gilbert
Diciembre 2003
- DTBC-243
Modeling a Small Open Economy: The Case of Chile
Vittorio Corbo y José Tessada
Diciembre 2003
- DTBC-242
Tax Incentives for Retirement Savings: Macro and Welfare Effects in an OLG-GE Model with Liquidity Constraints and Heterogeneous Consumers
Rodrigo Cifuentes
Diciembre 2003
- DTBC-241
A Toolkit for Analyzing Alternative Policies in the Chilean Economy
Rómulo Chumacero
Diciembre 2003
- DTBC-240
Banking Industry and Monetary Policy: An Overview
J. Rodrigo Fuentes y Luis Antonio Ahumada
Diciembre 2003
- DTBC-239
Tratado de Libre Comercio entre Chile y Estados Unidos: Revisión de Estudios que Cuantifican su Impacto
Mabel Cabezas
Diciembre 2003
- DTBC-238
Chile’s Regional Arrangements: The Importance of Market Access and Lowering the Tariff to Six Percent
Glenn W. Harrison, Thomas F. Rutherford y David G. Tarr
Noviembre 2003