



Modification to the AU11-07N slotted waveguide antenna of the Navy-Radar 4000

Daryl Ortega González, Pedro Arzola Morris, José R. Sandianes Gálvez

ABSTRACT

In marine and coastal radar applications it is usual to find antennas consisting of a slotted waveguide antenna and a horn antenna. To increase the effectiveness of the Cuban coastal surveillance system, it is proposed to modify the AU11-07N slotted waveguide antenna of the Navy-Radar 4000 based on the design of an optimal pyramidal horn antenna, causing the half power beamwidth to be reduced by half in the vertical plane. To achieve the objective, the original antenna is measured and modeled to then simulate it in the Ansoft HFSS software and compare it with the data from the radar manual. Then, the original antenna is modified based on the design of an optimal pyramidal horn, simulated and adjusted to the final dimensions based on the variation in the length of its plates. With the proposed modification, the half power beamwidth is achieved for the vertical plane of $11,30^\circ$ and for the horizontal plane of 0.71° , a secondary lobe level of -35 dB for the azimuth plane and a final gain of 34 dB, greater than that of the original antenna.

Key words: slotted waveguide antenna, slot, coastal surveillance, horn, Navy-Radar.

En aplicaciones de radares navales y costeros es usual encontrarse antenas compuestas por una antena de guía de onda ranurada y una antena de bocina. Para incrementar la efectividad del sistema de vigilancia costero cubano se plantea modificar la antena de guía de onda ranurada AU11-07N del Navy-Radar 4000 a partir del diseño de una antena de bocina piramidal óptima provocando la reducción a la mitad del haz de media potencia del sistema por el plano vertical. Para lograr el objetivo, se mide la antena original y se modela para posteriormente simularla en el programa Ansoft HFSS y compararla con los datos del manual del radar. Luego, la antena original es modificada a partir del diseño de una bocina piramidal óptima, simulada y ajustada a las dimensiones finales a partir de la variación del largo de sus placas. Con la modificación propuesta se logra un ancho del haz de media potencia por el plano vertical de 11.30° y por el plano horizontal de 0.71° , un nivel de lóbulos secundarios de -35 dB por el plano azimutal y una ganancia final de 34 dB, superior a la de la antena original.

Palabras claves: antena de guía de onda ranurada, ranura, vigilancia costera, bocina, Radar Naval.

Modificación a la antena de guía de onda ranurada AU11-07N del Navy-Radar 4000

1. -INTRODUCTION

Currently, Slotted Waveguide Antennas (SWA) are an essential part of a large number of Exploration Systems (ES) in marine environments; say naval and coastal radars [1-4]. These antennas are generally linear arrays of slots on the narrow face of the WR-90 waveguide for X-band applications [5, 6]. The advantages of aperture antennas [7-11] mean

that there are many examples of radars that use slotted antennas in combination with horn antennas to form an antenna composed of the two previous ones. This occurs because SWA in the horizontal plane provide very direct radiation beams and the horns cause a desired pattern in the vertical plane, so that by varying the dimensions of the horn the width of the radiation pattern is controlled in that plane[12-14]. In Cuba, the Furuno and Navy-Radar 4000 radars use this technology. The combination of the SWA with the horn antenna has the advantage of integration with existing designs, low cost and ease of construction.

In our country, “Las Tropas Guarda Fronteras (TGF)” have a network of naval radars of the Furuno and Transas brand for coastal surveillance, which act as a coastal radar. There are notable differences between naval and coastal radars according to parameters such as the radiation pattern of the antennas, the speed of rotation and the power of the transmitter, which means that the use of a naval radar for marine exploration from the coast does not be suitable.

The TGF direct their efforts to the manufacture of the first cuban coastal radar. Approximately two years ago, the radar research project of the research group of the same name from “Universidad Tecnológica de la Habana José Antonio Echeverría (CUJAE)” carried out, among others, the task of adapting the AU11-07N antenna of the radar network (Navy-Radar 4000) of the ES to one that conforms to the characteristics of a coastal radar antenna and thus increase the effectiveness of the surveillance system. In other words, the antenna of the Navy-Radar 4000 has a radiation pattern of 25° from the vertical plane to be able to make targets visible in the undulating conditions of the sea surface but to explore the sea from the coast (coastal radar) it is not necessary such a wide beam width that it is required to reduce approximately half of this pattern.

Within the framework of import substitution and technological independence, the intention is to manufacture a cuban radar in a second stage of the project and to adapt a Transas brand naval radar to a coastal one in its first stage. For this, the need to adjust the antenna of the Navy-Radar 4000 to the demands of the ES arises. From here, the present work aims to propose a modification to the AU11-07N antenna of the Navy-Radar 4000 to reduce its Half Power Beamwidth (HPBW) in the vertical plane by half, based on the design of a pyramidal horn antenna.

2. -CHARACTERIZATION OF THE AU11-07N ANTENA

In this section, the AU11-07N antenna is characterized from the measurement of its physical dimensions. The dispersion parameters of the same are measured with the Network Analyzer (NA) to see the behavior of its bandwidth and define, without margin for errors, if it is a traveling wave array or a resonant array. From the characterization of the antenna, it can be modeled in the HFSS software.

2.1. -PHYSICAL CHARACTERIZATION OF THE AU11-07N ANTENNA

After separating the antenna unit from the scanner and subsequently removing the antenna from the covering radome, the antenna under study is observed, which is a system formed by a SWA with the slots on the narrow face of the WR-90 waveguide with a load at its end and a flare-shaped structure in the opening with two metal plates on the vertical plane. In figure 1 the AU11-07N antenna with its physical dimensions is shown.

Table 1 summarizes some characteristics of the antennas used by Navy-Radar 4000, within which is the AU11-07N antenna. Among the collected parameters are the radiation pattern, the working frequency and the bandwidth. The antenna data taken from the Navy-Radar 4000 technical manual, the values in Table 1 and the physical measurements taken from the original antenna are summarized below (with reference in figure 2). The inclination angle (θ) of the slots varies from 2° to 7.8° in the first 65 slots and then from 7.8° to 2.4° in the remaining 21 slots with steps of 0.08° and 0.25° respectively, showing a typical characteristic of the traveling wave arrays:

- Number of slots in the array: $N = 86$
- WR-90 waveguide: $a = 22.86\text{mm}$, $b = 10.16\text{mm}$, wall thickness ($t = 1.75\text{mm}$)
- Working frequency: $f_0 = 9.41\text{ GHz}$
- Free space wavelength: $\lambda_0 = 0.03188\text{m}$ (3.188cm)
- Guide wavelength: $\lambda_g = 0.04481\text{m}$ (4.48 cm)
- Slot width: $w_r = 0.175\text{cm}$ (1.75mm)
- Separation between slots (d_r): 2.535 cm
- Spacing between slots with respect to λ_g : $2.535 / 4.48 = 0.5658$

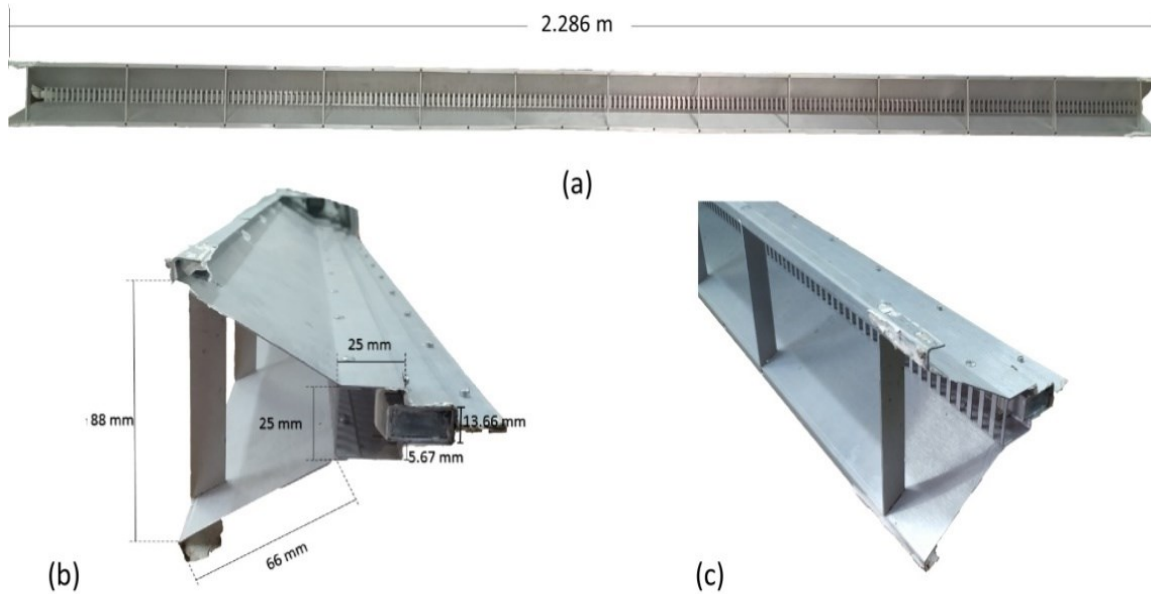

Figure 1

AU11-07N antenna. a) Front view, b) Side view, c) Perspective view.

Table 1
 Technical specifications of the antennas used by the Navy-Radar 4000

Array Model	AU11-04N	AU11-06N	AU11-07N	AU11-09N
Length	4 feet(1.22 m)	6 feet(1.83 m)	7.5 feet(2.28m)	9 feet(2.74 m)
Frequency Band	X Band, $\lambda = 3.2$ cm, frequency range 9410 ± 50 MHz			
Horizontal HPBW	$1.8^\circ \pm 0.1^\circ$	$1.25^\circ \pm 0.1^\circ$	$1.05^\circ \pm 0.1^\circ$	$0.85^\circ \pm 0.1^\circ$
Vertical HPBW	$25^\circ \pm 10\%$	$25^\circ \pm 10\%$	$25^\circ \pm 10\%$	$25^\circ \pm 10\%$
Side Lobe Level (SLL) within 10°	≤ -24 dB	≤ -26 dB	≤ -26 dB	≤ -25 dB
Side Lobe Level (SLL) without 10°	≤ -28 dB	≤ -30 dB	≤ -30 dB	≤ -30 dB
Gain	≥ 27 dBi	≥ 29 dBi	≥ 30 dBi	≥ 30 dBi

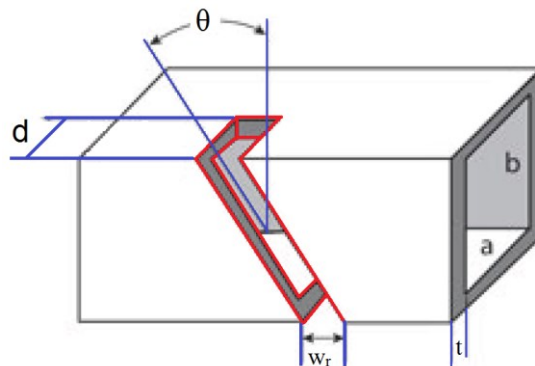

Figure 2

Detail of the slot dimensions in the WR-90 waveguide.

2.2. -MEASUREMENT OF THE RETURN LOSSES (RL) AND THE STANDING WAVE RATIO (SWR) OF THE AU11-07N ANTENNA

Return Loss (RL) and Standing Wave Ratio (SWR) measurements make it possible to determine what type of array the AU11-07N antenna is. The measurements were carried out in the wireless communications laboratory of the Department of Telecommunications and Telematics. For these, the network analyzer model ZVB-20 of the Rohde and Schwarz Company was used. To carry out the measurements, a piece was adapted that allowed the waveguide to be coupled with the SMA connector used (figure 3b and c), reducing leaks due to lack of electrical contact to a minimum. In figure 3 the measurement process is shown.

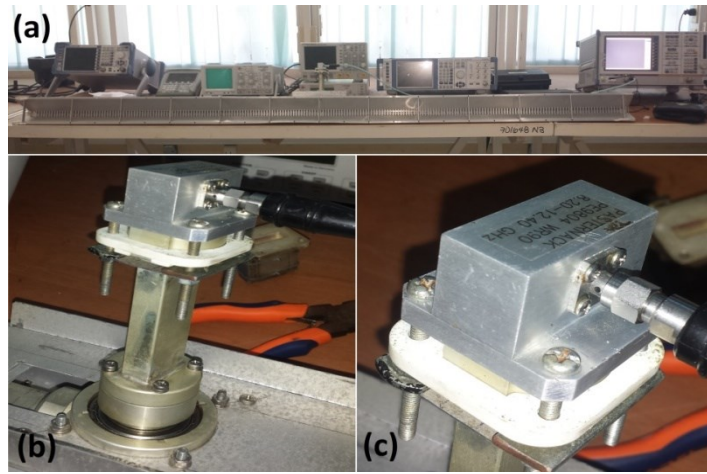

Figure 3

Measurement of the AU11-07N antenna with the Network Analyzer model ZVB- 20.

Parameter S_{11} , representing return losses, is shown in the graph in figure 4. For the antenna operating frequency 9.41 GHz, the parameter $S_{11} = -27$ dB corroborating the expected result. From the same graph it is extracted that the antenna under study has a considerable bandwidth.

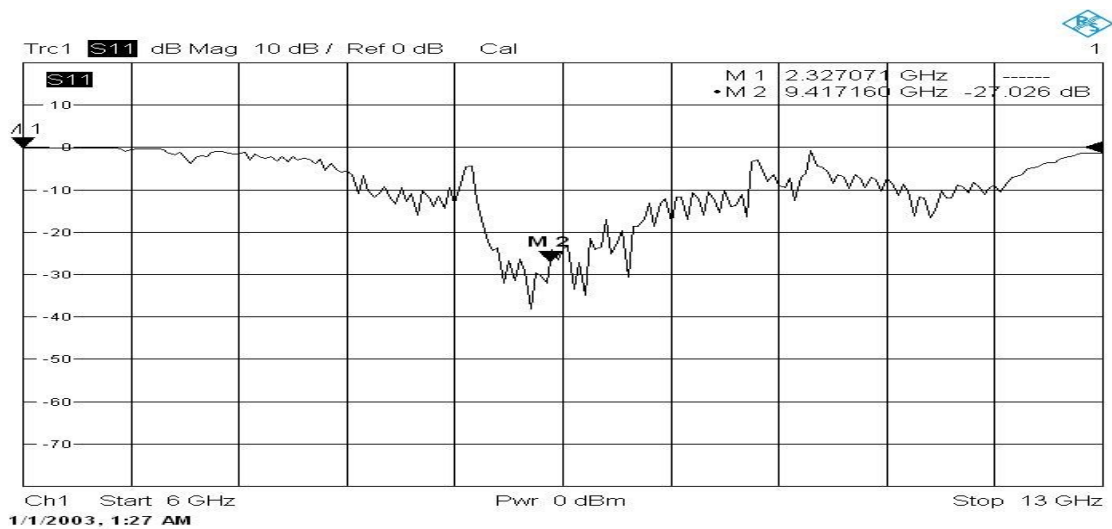

Figure 4

S_{11} vs frequency.

The graph of the SWR in figure 5 gives new values that allow us to assess whether the antenna is a resonant array or a traveling wave antenna. At the design frequency, $SWR = 1.26$. The antenna bandwidth for $SWR < 2$ is 885 MHz. It is concluded that from the measurement of the slots separation unequal than $\lambda_g/2$ and the bandwidth recorded in the SWR measurement, the antenna is a traveling wave linear array with slots on the narrow face of the WR-90 waveguide. The antenna has a load at its end that as a general rule must absorb 5% of the input power of the antenna.

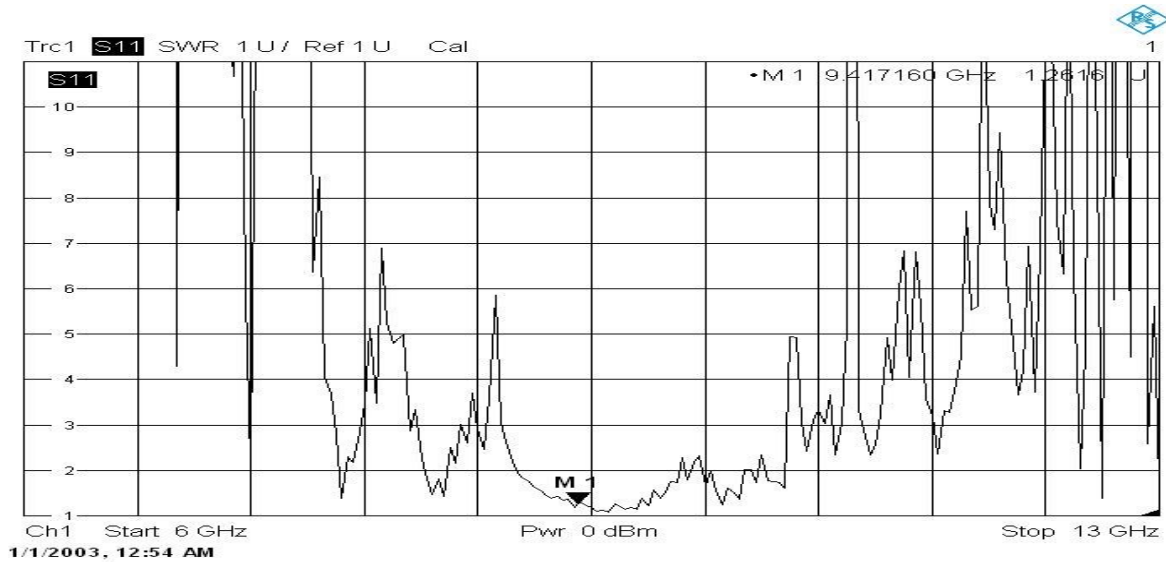

Figure 5
SWR vs frequency.

3. -SIMULATION OF THE AU11-07N ANTENNA IN THE ANSOFT HFSS SOFTWARE

The AU11-07N antenna is implemented in Ansoft HFSS Electromagnetic Software (EMS) to obtain its radiation characteristics. The model generated in HFSS complies with the measurement of the physical variables of the antenna. Two radiation ports are defined in the simulation model on both sides of the WR-90 waveguide to obtain the progressive wave condition, aluminum is assigned as the material for the model, the other boundary and radiation conditions are assigned relevant [15-17]. Figure 6 shows how the structure designed in the HFSS was.

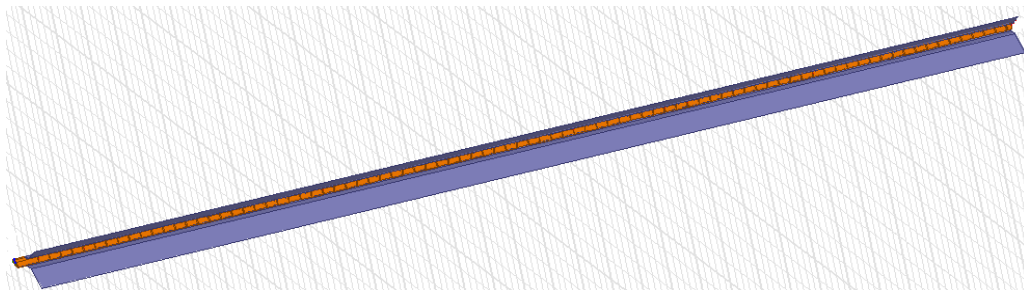

Figure 6
Model of the AU11-07N antenna in HFSS.

The graph of figure 7 shows the simulation results for the rectangular diagram of the radiation pattern in the vertical plane. In it, the width of the HPBW that has a value of $25,048^\circ$ is indicated with markers. This result validates the accuracy of the designed model by matching the beamwidth data of the radiation pattern of the antenna by the vertical plane (see Table 1). The SLL is below -24 dB; It turns out that it corresponds to the typical characteristics of a radar antenna in a coastal environment.

Figure 8 shows the radiation pattern of the AU11-07N antenna on the horizontal plane. The same figure shows that the HPBW is 0.71° . This value corresponds to the typical value of a coastal radar antenna along the horizontal plane and is very close to the actual value of $1.05^\circ \pm 0.1^\circ$ (see Table 1). The SLL is below -35 dB, in correspondence with the values in Table 1.

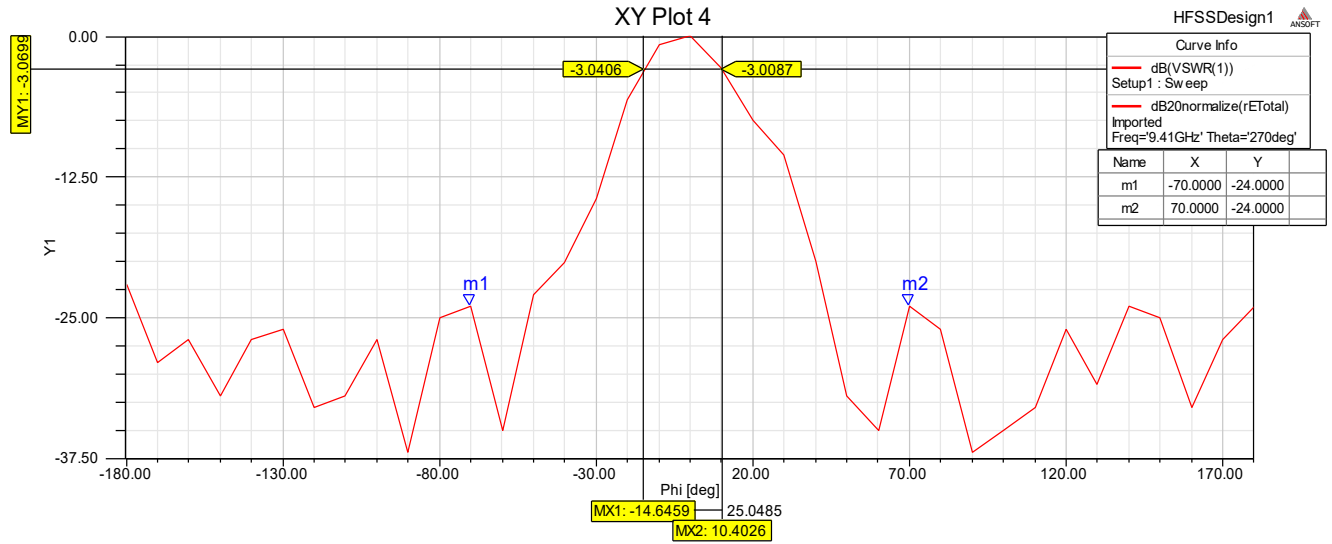

Figure 7

Radiation pattern of the AU11-07N antenna simulated in the vertical plane.

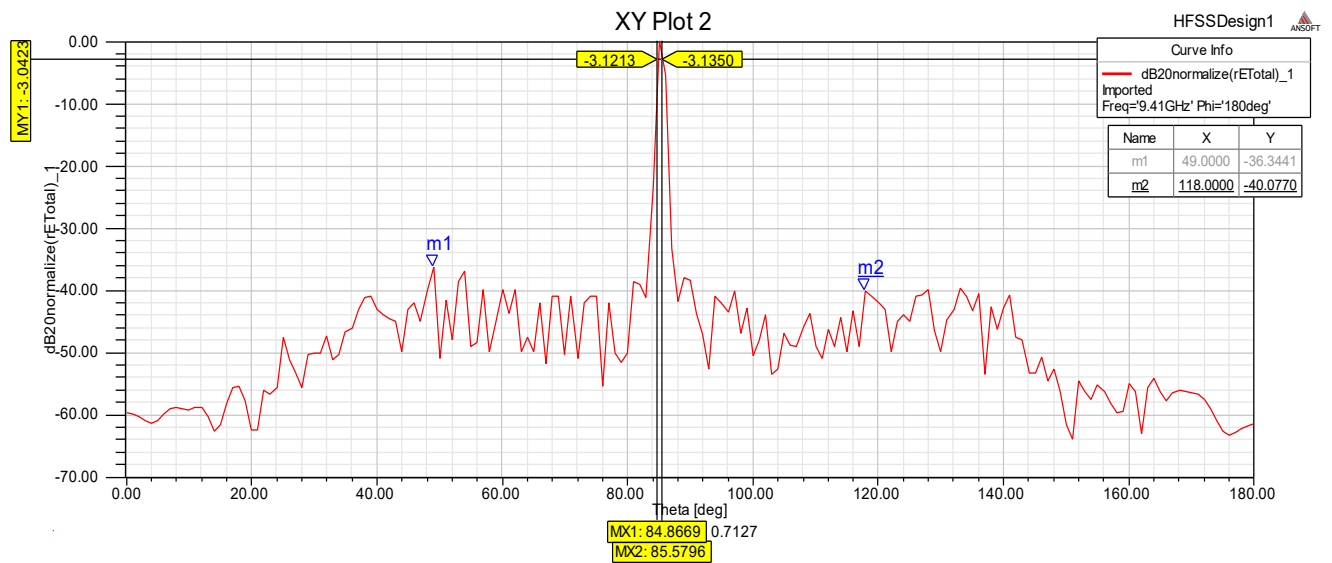

Figure 8

Radiation pattern of the AU11-07N antenna simulated in the horizontal plane.

4. -DESIGN AND SIMULATION OF THE MODIFICATION TO THE AU11-07N ANTENNA OF THE NAVY-RADAR 4000

Based on the final specifications to be obtained, the design of an optimal pyramidal horn antenna is proposed as a modification to the AU11-07N antenna on the vertical plane. Based on the design of the optimal pyramid horn antenna, the original antenna is modified. The proposed modification is simulated in HFSS and then the plate length is parameterized through the Optimetric Analysis tool.

4.1. - FINAL DESIGN SPECIFICATIONS

The modified antenna as a whole must comply with a final directional diagram of 12° for the vertical plane, and the same HPBW for the horizontal plane. It is required to halve, approximately, the diagram of the radiation pattern along the vertical plane. This value is a compromise criterion between the size and weight of the antenna and its gain, since as the HPBW is reduced, the gain increases, but the physical dimensions and weight of the antenna also increase, making it impossible to mount.

In order to ensure that the design is compatible with the specifications of a coastal radar and with the HPBW in both planes in the far zone, the following characteristics summarized in Table 2 must be met.

Table 2
Final design parameters

Characteristic	Value
Operation frequency	9,41 GHz (X Band)
wavelength	0,032 m ($\approx 3,2$ cm)
Polarization	lineal
Gain	>30 dB
HPBW of the system for the H plane	12°
HPBW of the system for the E plane	$1.05^\circ \pm 0.1^\circ$
SLL(vertical Plane)	-25 dB
SLL(horizontal plane)	-35 dB

It is considered important that the design is easy to build and low cost, so that its implementation is feasible with the materials and technology available in the country.

4.2. - DESIGN OF THE OPTIMAL PYRAMIDAL HORN ANTENNA

From the design equations of the optimal pyramidal horn antenna [14], implemented in the mathcad software, the theoretical design of a pyramidal horn antenna is proposed. The HPBW must be 12° for both planes. With this model, which is the ideal, it is intended to have an initial idea of the physical dimensions of a horn antenna that meets these requirements. The modification to be made to the AU11-07N antenna is based on that first ideal design.

Table 3 contains the data required for the design of the optimal pyramidal horn antenna and the final results of the horn antenna design provided by Mathcad software. In figure 9 the designed pyramidal horn antenna is shown.

Table 3
Initial data and final design results of the optimal pyramid horn antenna

Initial Data		Design Results	
Parameter	Value	Parameter	Value(cm)
a(wr-90)	22,86 mm	a _a	20.723
b(wr-90)	10,16 mm	b _b	14.878
f(frequency)	9,41 GHz	R _e	45.249
HPBW(Vertical Plane)	12°	R _h	47.386

HPBW(Horizontal Plane)	12°	$L_e=L_h$	42.159
------------------------	-----	-----------	--------

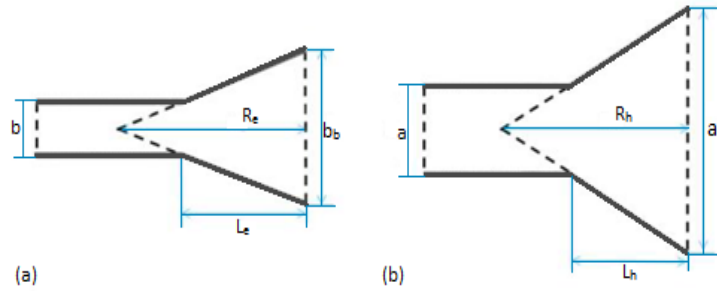

Figure 9

Optimal pyramidal horn antenna. a) Side view (E Plane), b) Top view (H Plane).

The theoretical prediction model of the radiation pattern for both planes for the designed pyramidal horn is illustrated in figure 10, where it is effectively verified that the resulting HPBW is approximately 12° in both planes, the vertical plane(H plane) being the one of interest.

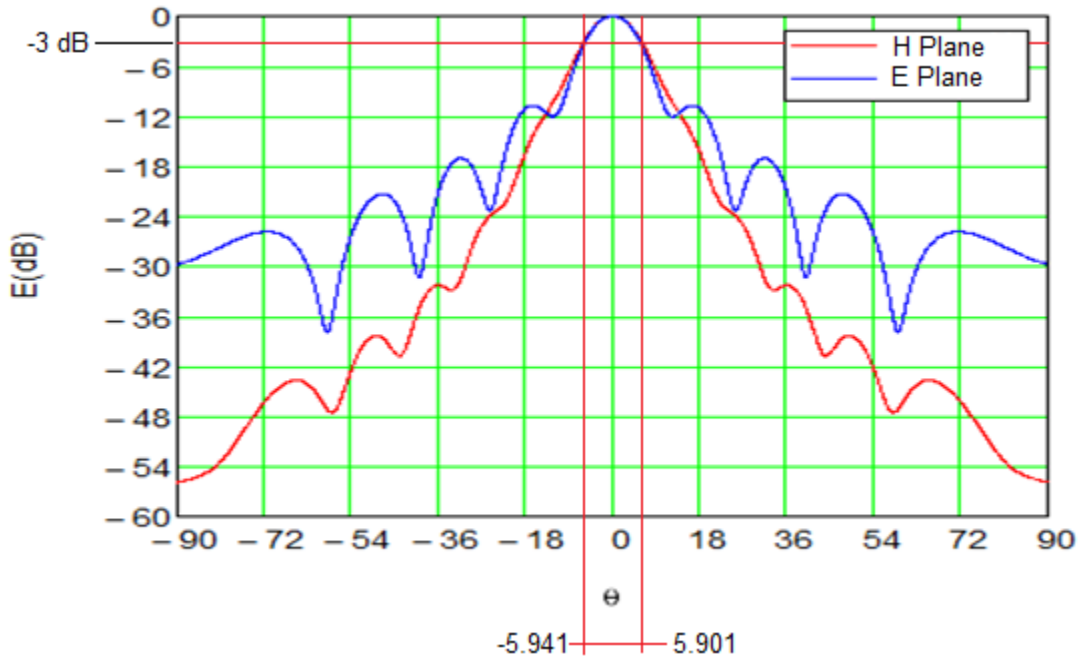

Figure 10

Theoretical radiation pattern from both planes.

4.3. -MODIFICATION TO THE ANTENNA (REDUCTION OF THE ANGLE AND EXTENSION OF THE HORN BY THE H PLANE)

The modification of the physical variables of the antenna is proposed so that the final result corresponds to the theoretical design of the optimal horn antenna to obtain 12° in the vertical plane. It starts from the dimensions of the pyramidal horn antenna discussed in the previous section. The modification to the AU11-07N antenna consists of two steps: the first one is the reduction of the angle of the opening along the vertical plane and a second stage that consists of lengthening the antenna horn. The angle of the opening through the vertical plane is reduced from 27,59°, which is

that of the original antenna, to 9.332° . The horn plates lengthen from 6.8 cm to 43.32 cm, representing an elongation of 36.52 cm. The initially proposed modification is shown in figure 11.

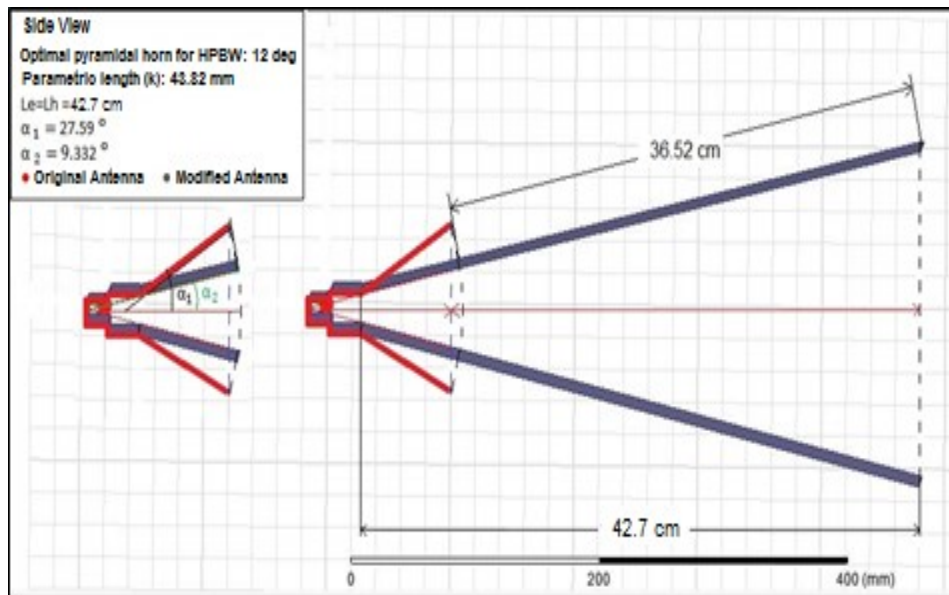

Figure 11

Initial modification to the antenna AU11-07N.

4.4. -SIMULATION OF THE MODIFICATION. PARAMETRIZATION OF THE LENGTH OF THE PLATES

To simulate this structure, which has a surface area greater than 2 m^2 if the two plates that form it are added, the HFSS-IE model is used, which uses the Method of Moments (MoM) to calculate the currents on the surface of the materials and is powered to solve large open problems. The model of the structure in HFSS is shown in Figures 12 and 13.

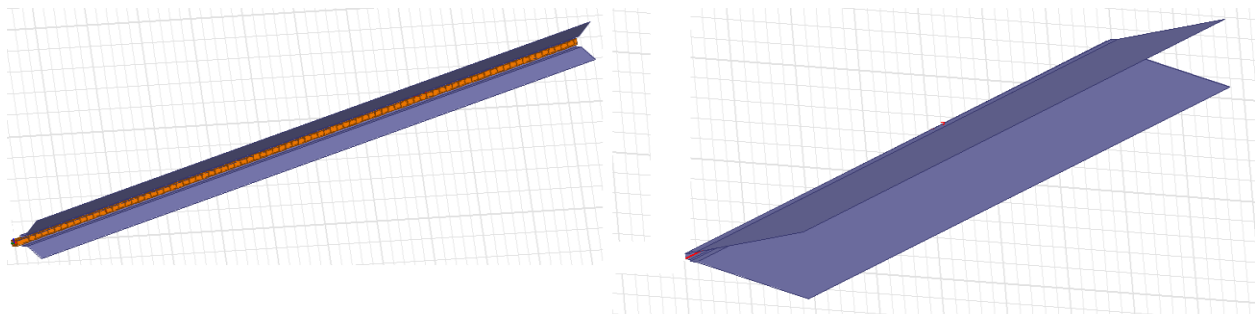

Figure 12

Original and modified antenna



Figure 13

Top view of the modification made

The theoretical prediction model allows establishing the data of the starting physical dimensions. The antenna is simulated with the proposed modifications based on the optimal pyramidal horn design model. From these initial values it can be use the tool: Optimetric, Parametric Setup of the HFSS. By means of the parametric sweeps of the physical variables of the horn, the final dimensions of the design that corresponds to the HPBW closest to 12° can be obtained. This sweep is in the order of millimeters and is performed around the value of the length of the plates of the optimal horn.

The variation is made from the inner opening to the outer opening. The length of the horn plates perpendicular to the vertical plane is varied from 41.32 cm to 45.32 cm with 5mm steps around the optimal theoretical central value of 43.32 cm. From the simulated models, the radiation pattern that has a lower SLL and a well-defined main lobe with a width below 12° is extracted. This result is selected as it is the one that best fits the final system requirements shown in Table 2. The length of the horn plate corresponding to this diagram is 43.82 cm. Subtracting the magnitudes 43.82 cm and 6.8 cm, which is the length of the original antenna plate, the increase in figure 14 of 37.02 cm is shown.

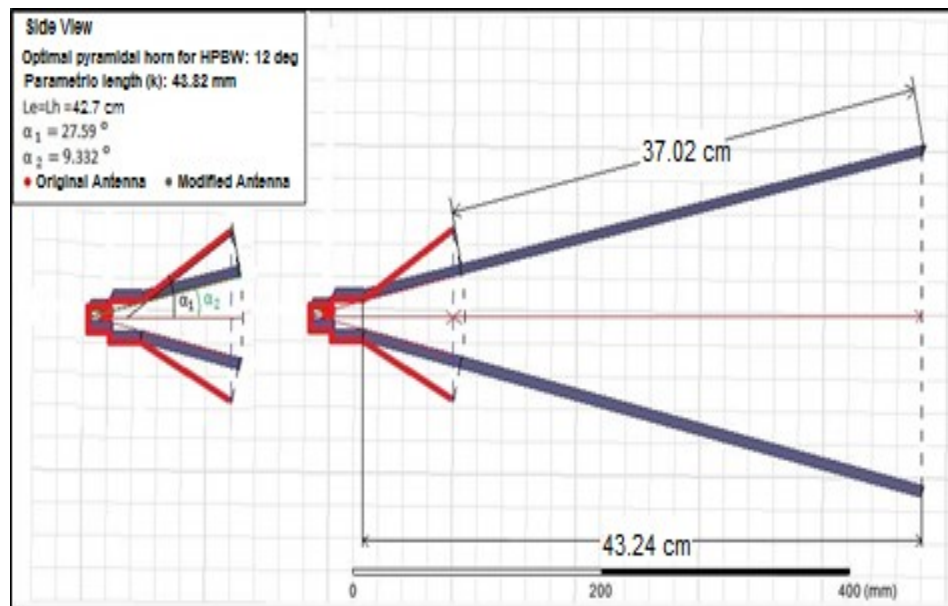

Figure 14

Modification to the antenna AU11-07N after parametric scan.

Figure 15 shows the radiation pattern of the antenna whose final dimensions correspond to those illustrated in figure 14.

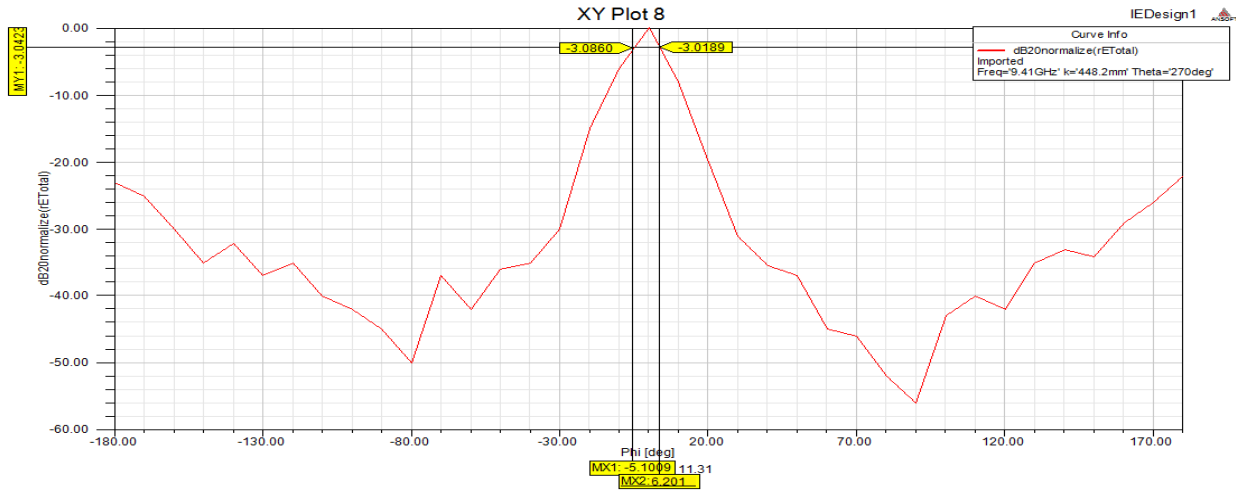

Figure 15

Radiation pattern of the antenna modified in the vertical plane for a plate length of 43.82 cm.

It shows how the HPBW for the vertical plane is reduced to $11,30^\circ$, a result closer to the design specifications. This result indicates that with the new dimensions, the maximum offset at the end of the horn opening corresponds to the lowest HPBW for this particular antenna, maintaining the same angle of the opening.

Figure 16 shows a comparison of the radiation pattern for this parametric length and that of the AU11-07N antenna, where a decrease in HPBW by the vertical plane of $13,7^\circ$ is observed in markers.

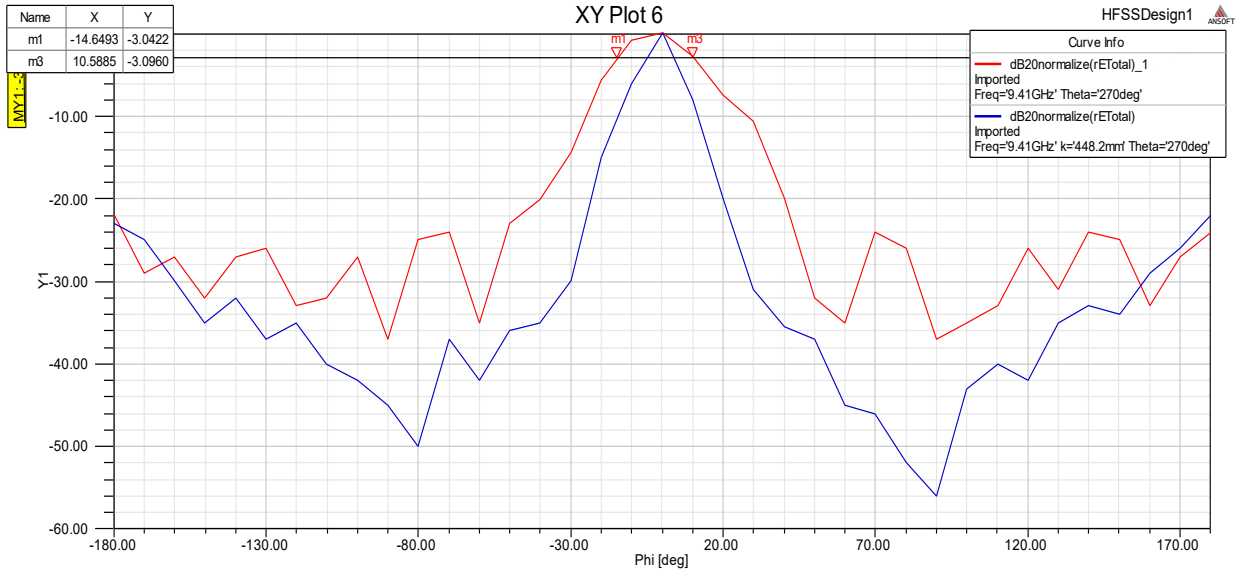

Figure 16

Comparison of the radiation pattern in the vertical plane between the AU11-07N antenna and the modified antenna.

The radiation pattern in the horizontal plane is maintained with a half power beamwidth of approximately $0,71^\circ$ as can be seen in figure 17 and the SLL is maintained below -35 dB. This represents an expected result since the antenna conditions are not altered by the horizontal plane.



Figura 17

Radiation pattern in the horizontal plane.

5. - THEORETICAL ANALYSIS OF GAIN

Based on equation (1) the maximum antenna gain can be determined with directive radiation patterns [13]:

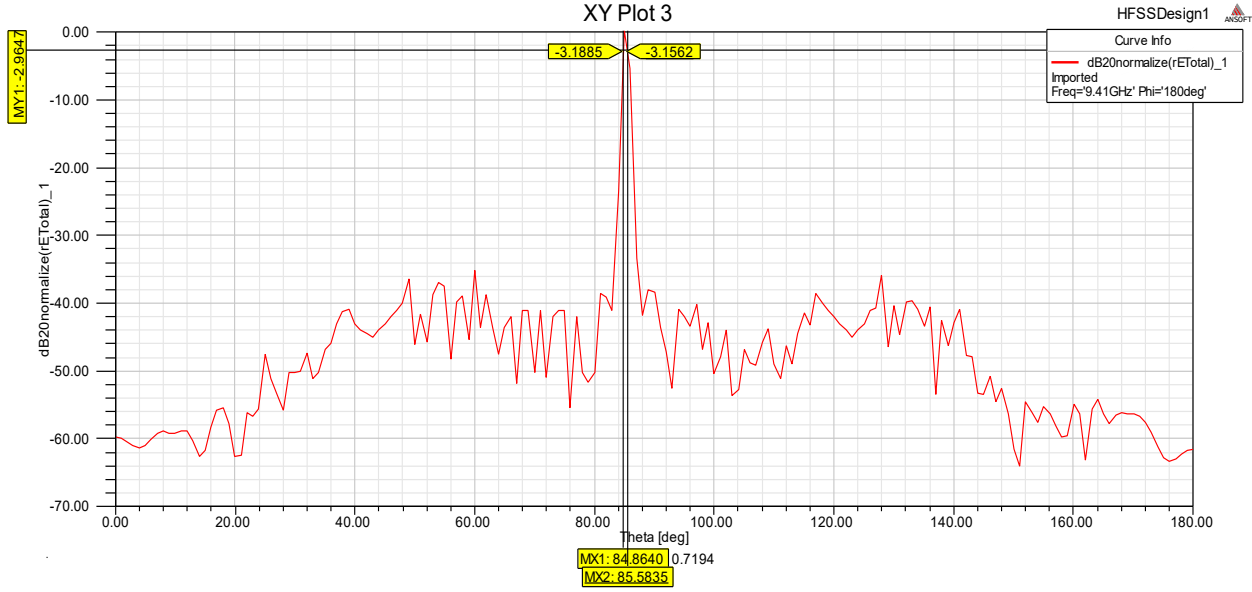
$$G_0[dB] = 10 * \log_{10} \left(\frac{30000}{\Phi_{1d} \Phi_{2d}} \right) \quad (1)$$

In this equation Φ_{1d} is the angle of half power in one plane and Φ_{2d} is the angle of half power in a plane perpendicular to the previous one. From the original radar data $\Phi_{1d} = 25^\circ$ and $\Phi_{2d} = 1^\circ$ from equation (1) it is possible to estimate the gain of the naval radar antenna at $G_0 = 30.79$ dB. Based on the same formula with the modified antenna, in which the HPBW in the vertical plane is reduced to 11.27° from the result obtained in the parameterization, a gain of approximately $G_0 = 34.24$ dB is obtained. Therefore, more than 4 dB of gain is achieved with the proposed modification.

6. -CONCLUSIONS

From the physical measurement, the RL and the SWR of the AU11-07N antenna, it is possible to characterize it and modeled it assuming a power dissipation in the load of 5%. The characterized antenna was simulated in the Ansoft HFSS EMS and the results corresponded with the data from the radar technical manual, endorsing the results that were subsequently obtained by modifying that antenna.

The modification of the AU11-07N antenna is carried out in two steps: reduction of the angle of the original horn from $27,59^\circ$ to $9,332^\circ$ and lengthening of the horn plates from 6.8 cm to 43.82 cm. From the results obtained in the simulation, it was extracted that the HPBW for the vertical plane decreases from approximately 25° to $11,30^\circ$ and it is indicated that the SLL is < -25 dB. On the horizontal plane, there were no significant changes as the HPBW remained at $0,71^\circ$. The SLL in that plane does not exceed -35 dB. With the proposed modification, the antenna gain increases by 4 dB, making it possible for the target to be illuminated with more energy and also to receive more energy as a result of reflection, increasing the probability of detection. The changes to be made in the AU11-07N antenna are discreet and guarantee the viability of the modification presented by weight and area since for future manufacturing it is planned to use 0.5 mm aluminum plates, making the weight increase the smallest possible. The stated objectives are met and it is possible to present a modification proposal that complies with the system specifications.

REFERENCES

1. Misilmani HME, Al-Husseini M, Kabalan KY. Design of Slotted Waveguide Antennas with Low Sidelobes for High Power Microwave Applications. *Progress In Electromagnetics Research*. 2015;56(1):15-28.
2. Chou K-R, Lin H-N, Lu W-H, Chang H-W, Tiong K-K. Design and operation of an edge-wall slotted waveguide antenna with ultralow side lobes for application of off-shore Radar. *Journal of Marine Science and Technology*. 2015;23(5):620-7.
3. Murugaveni S, arthick TK. Design of Slotted Waveguide Antenna for Radar Applications at X-Band. *International Journal of Engineering Research & Technology (IJERT)*. 2014;3(11): 426-428.
4. Enjiu R, Perotoni MB. Slotted Waveguide Antenna Design Using 3D EM Simulation. *Microwave Journal*. 2013.
5. Keller SD, Weiss SJ, Farley BT. Edge Slot Waveguide Array Antenna for an Omnidirectional Radar System. *US Army*, 2016; 1-12.
6. Volakis JL. *Antenna Engineering handbook*. 4th ed: MacGraw-Hill; 2007.
7. Zhu J, Liao S, Li S, Xue Q. 60 GHz Dual-Circularly Polarized Planar Aperture Antenna and Array. *IEEE Transactions on Antennas and Propagation*. 2018;66(2):1014-9.
8. Manohar V, Kovitz JM, Rahmat-Samii Y. Synthesis and Analysis of Low Profile, Metal-only Stepped Parabolic Reflector Antenna. *IEEE Transactions on Antennas and Propagation*. 2018;66(6):2788-98.
9. Fonseca NJG, Girard E, Legay H. Doubly Curved Reflector Design for Hybrid Array Fed Reflector Antennas. *IEEE Transactions on Antennas and Propagation*. 2018;PP(99):1-5.
10. Wan X, Zhang L, Jia SL, Yin JY, Cui TJ. Horn Antenna with Reconfigurable Beam-Refraction and Polarization Based on Anisotropic Huygens Metasurface. *IEEE Transactions on Antennas and Propagation*. 2017;65(9):4427-4434.
11. Mateo J, Torres AM, Belenguer A, Borja AL. Highly Efficient and Well-Matched Empty Substrate Integrated Waveguide H-plane Horn Antenna. *IEEE Antennas and Wireless Propagations Letters*. 2016;15:1510-1513.
12. Chen ZN, Liu D, Nakano H, Qing X, Editors TZ. *Handbook of Antenna Technologies*: Springer Nature; 2015.
13. Balanis CA. *Modern Antenna Handbook*: John Wiley And Sons; 2008.
14. Stincer EP. *Antenas Teoria General*: Imprenta ITM José Martí; 2001. 527 p.
15. González DO, Morris PA. Diseño de antena de bocina con corrugaciones variables para aplicaciones de Radar. *Convencion Internacional Informática 2018, VIII Simposio de Telecomunicaciones*; La Habana, Cuba, 2018. Available in: <http://www.informaticahabana.cu/es/node/4275>
16. TEJA MLR, SRI GNSB, RAO VD. Designing and Studying the Characteristics of Rectangular Waveguides using HFSS. *Proceedings of 48th IRF International Conference*; India2017. Available in: <https://ieeexplore.ieee.org/document/830093>
17. Kamath HS, Arora R, Agarwal V. Studying the Characteristics of a Rectangular Waveguide using HFSS. *International Journal of Computer Applications*. 2015;118(1).

CONFLICT OF INTERESTS

None of the authors stated the existence of possible conflicts of interest that should be declared in relation to this paper.

AUTHORS' CONTRIBUTIONS

Daryl Ortega González: Conceptualization, Data Curation, Formal Analysis, Research, Methodology, Project Management, Resources, Software, Validation-Verification, Visualization, Drafting-original draft, Drafting-reviewing and editing.

Pedro Arzola Morris: Conceptualization, Data Curation, Formal Analysis, Fund Acquisition, Research, Methodology, Project Administration, Supervision.

José R. Sandianes Gálvez: Conceptualization, Data Curation, Formal Analysis, Research, Methodology, Project Administration, Supervision.

AUTHORS

Daryl Ortega González, Telecommunications and Electronic Engineer, Universidad Tecnológica de la Habana José Antonio Echeverría (CUJAE), La Habana, Cuba, e-mail: fedortegag@gmail.com, ORCID: 0000-0002-9272-4553, currently works and interested in reflector antennas, reflectarray, phased arrays, reconfigurable antennas, adaptive antennas and smart antennas.

Pedro Arzola Morris, Radiotechnical Engineer, Master of Science, Universidad Tecnológica de la Habana José Antonio Echeverría (CUJAE), La Habana, Cuba, e-mail: pedro.amorris@gmail.com, ORCID: 0000-0002-1146-5749, currently works and interested in Antenna Theory and Radar applications.

José R. Sandianes Gálvez, Radiotechnical Engineer, Doctor of Science, Universidad Tecnológica de la Habana José Antonio Echeverría (CUJAE), La Habana, Cuba, e-mail: sandianes@tele.cujae.edu.cu, ORCID: 0000-0003-1391-1236, currently works and interested in Antenna Theory and Radio propagation.



Esta revista se publica bajo una [Licencia Creative Commons Atribución-No Comercial-Sin Derivar 4.0 Internacional](https://creativecommons.org/licenses/by-nc-nd/4.0/)