

**Psychometric properties of the Knowledge and Understanding Questionnaire of the Canadian Assessment of Physical Literacy-2 in low-income Brazilian children**  
**Propiedades psicométricas del Cuestionario de Conocimiento y Comprensión de la Evaluación Canadiense de Alfabetización Física-2 en niños brasileños de baja renta**  
**Propriedades psicométricas do Questionário de Conhecimento e Compreensão do Canadian Assessment of Physical Literacy-2 em crianças brasileiras de baixa renda**

\*Jéssica Gomes Gonçalves, \*\*Leonardo Gomes de Oliveira Luz, \*\*\*Paulo Felipe Ribeiro Bandeira, \*\*\*\*Thaliane Mayara Pessôa dos Prazeres, \*Victor Ferreira Lima, \*Douglas Eduardo Ferreira Maia, \*Tony Meireles dos Santos, \*\*\*\*\*Anelise Reis Gaya, \*\*\*\*Marcos André Moura dos Santos, \*Rafael dos Santos Henrique

\*Federal University of Pernambuco (Brazil), \*\*Federal University of Alagoas (Brazil), \*\*\*Regional University of Cariri (Brazil),  
 \*\*\*\*\*University of Pernambuco (Brazil), \*\*\*\*\*Federal University of Rio Grande do Sul (Brazil)

**Abstract.** This study aimed to translate and cross-culturally adapt the Physical Literacy Knowledge (PLK) questionnaire from Canadian Assessment of Physical Literacy-2 for Portuguese version, and to evaluate its psychometric properties (construct validation, content, composite reliability, measurement invariance) in low-income Brazilian children. The sample comprised of 562 children (247 girls), aged between 8.00 and 12.99 years-old ( $10.20 \pm 1.20$  years), enrolled in the 12 public-school in Lagoa do Carro city, Pernambuco, Brazil. A translation and cross-cultural adaptation of the PLK questionnaire was carried out. Content validity was determined by calculating the content validity coefficient, which assesses the relevance, clarity and pertinence of total (CVCt) and each question individually (CVCi). The dimensional structure of the PLK and alternative models were considered with first and second order models. Internal consistency was assessed using composite reliability. Structural invariance (configural, metric, scalar and strict) between sexes was also assessed using a multigroup factor analysis. Content validity was considered acceptable, varying between 0.88 and 1.00 for CVCi, and 0.91, 0.94 and 0.99 for clarity, pertinence and relevance in the CVCt, respectively. Construct validity was considered adequate, with 3 dimensions and 9 items model being the most appropriate [ $\chi^2(df)=34.01(24)$ ; CFI=0.92; TLI=0.87; RMSEA=0.03; SRMR=0.04; 90% CIRMSEA=0.00-0.05]. The questionnaire was structurally invariant (all  $\Delta CFI < 0.05$ ). Based on the findings, the PLK questionnaire has adequate psychometric properties to assess the cognitive domain of Physical Literacy in low-income Brazilian children.

**Key-words:** Physical Literacy; Cognition; Children; Psychometry; Child Development.

**Resumen.** Este estudio tuvo como objetivo traducir y adaptar transculturalmente el cuestionario Physical Literacy Knowledge (PLK) del Canadian Assessment of Physical Literacy-2 para la versión en portugués, y evaluar sus propiedades psicométricas (validación de constructo, contenido, fiabilidad compuesta y invarianza de medida) en niños brasileños de baja renta. La muestra comprendió 562 niños (247 niñas), con edades entre 8,00 y 12,99 años ( $10,20 \pm 1,20$  años), matriculados en las 12 escuelas públicas de la ciudad de Lagoa do Carro, Pernambuco, Brasil. Se realizó una traducción y adaptación transcultural del cuestionario PLK. La validez de contenido se determinó mediante el cálculo del coeficiente de validez de contenido, que evalúa la relevancia, claridad y pertinencia del total (CVCt) y de cada pregunta individualmente (CVCi). La estructura dimensional del PLK y los modelos alternativos se consideraron con modelos de primer y segundo orden. La consistencia interna se evaluó mediante la fiabilidad compuesta. También se evaluó la invarianza estructural (configural, métrica, escalar y estricta) entre sexos mediante un análisis factorial multigrupo. La validez de contenido se consideró aceptable, variando entre 0,88 y 1,00 para el CVCi, y 0,91, 0,94 y 0,99 para claridad, pertinencia y relevancia en el CVCt, respectivamente. La validez de constructo se consideró adecuada, siendo el modelo de 3 dimensiones y 9 ítems el más apropiado [ $\chi^2(df)=34,01(24)$ ; CFI=0,92; TLI=0,87; RMSEA=0,03; SRMR=0,04; 90% CIRMSEA=0,00-0,05]. El cuestionario fue estructuralmente invariable (todos los  $\Delta CFI < 0,05$ ). Con base en los resultados, el cuestionario PLK tiene propiedades psicométricas adecuadas para evaluar el dominio cognitivo de la Alfabetización Física en niños brasileños de bajos ingresos.

**Palabras clave:** Alfabetización física; Cognición; Niños; Psicometría; Desarrollo Infantil.

Fecha recepción: 23-04-24. Fecha de aceptación: 13-06-24

Rafael dos Santos Henrique  
 rafael.shenrique@ufpe.br

## Introduction

Physical literacy (PL) has been described as the motivation, confidence, competence, knowledge and understanding to value and take responsibility for engagement in physical activities for life (IPLA, 2017). Given the growing concern to promote strategies for an active and healthy lifestyle from early childhood, PL has gained popularity in several countries, such as Canada (Tremblay et al., 2018), Australia (Keegan et al., 2019), among others (Carl et al., 2023; Hurter et al., 2022; Li et al., 2022; Martins et al., 2021), besides serving as the basis for physical activity and sports for children and adolescents (Edwards et al., 2017; Keegan

et al., 2017; Carolo et al., 2023). However, initiatives and studies in the northern hemisphere predominate (Contreas-Zapata et al., 2023).

Canada is recognized as one of the most prominent countries in the proposition of tools for the PL assessment, especially by the proposition of the Canadian Assessment of Physical Literacy (CAPL) – first and second version (Corbin, 2016; Gunnell et al., 2018), which allows the assessment of four domains individually (i.e., physical, cognitive, psychological and behavioral domains), as well as a composite score of PL. Longmuir et al. (2015), in a sample of 489 children, showed that the CAPL obtained satisfactory indicators in all domains evaluated. Gunnell et al.

(2018), in turn, reviewed the structural model and the factorials of the CAPL, and proposed a second version of it.

The evaluation of the psychometric properties of CAPL has been also verified in other countries (Greece, China and Denmark). For example, Dania, Kaioglou & Ventsanou (2020) observed that the full factorial structure of the CAPL-2 met satisfactory fit indices (RMSEA=0.04; CFI=0.91 and TLI=0.87). In China, Li et al. (2020) found satisfactory fit indices (RMSEA=0.04; CFI=0.94 and TLI=0.90), however the model was adjusted only when questions from the cognitive domain and the psychological domain were removed. Cognitive domain had also low reliability when analyzed separately. In a study carried out with Danish children, Elsborg et al. (2021) showed acceptable fit indices (RMSEA=0.04; CFI=0.97 and TLI=0.96).

The cognitive domain assessment is represented by knowledge and understanding of recommendations for physical activity and sedentary behavior, knowledge of physical fitness definitions (musculoskeletal and cardiorespiratory), ways to improve fitness and sport skills, among others (Longmuir et al., 2018). For instance, Longmuir et al. (2018) conducted a Delphi panel with experts and indicated that the knowledge questionnaire of the CAPL-2 (PLK) with fewer questions should achieve better feasibility. In a review study, Shearer et al. (2021) showed that only two of the 52 included studies performed an explicit assessment of this domain, the CAPL-2 and the Physical Literacy Assessment for Youth (PLAYtools). Recently, other instruments were also created, considering the cognitive domain in their evaluation (Barnett et al., 2022; Mota et al., 2021). However, no instrument has been used or validated to assess PL in South America, and especially in low-income children. In many Latin American countries, especially in regions with greater social vulnerability, contextual characteristics (e.g., region, availability of equipment for motor experiences, health practices and public policies) may affect the way in which each individual perceives their health condition and recognizes ways of modifying it (Santos et al., 2022), may consequently influence the PL of schoolchildren.

In recent years, several psychometric indicators have been suggested to obtain more robust versions of a scale, which we can mention the composite reliability analysis and the verification of different sources of invariance. Thus, the present study aimed to translate and cross-culturally adapt the Portuguese version of the PLK, in addition to evaluating its psychometric properties (construct validation, content, composite reliability, measurement invariance) in low-income Brazilian children.

## Material and Methods

### Sample

This research is part of the Healthy Life Project in Lagoa do Carro: a family-based study, which investigated the relationships between physical growth, motor development and health aspects among children and adolescents in the

Lagoa do Carro, northeastern Brazil. It is a cross-sectional and school-based study, following the recommendations of Strengthening the Reporting of Observational Studies in Epidemiology (Von Elm et al., 2014). However, the guidelines of the COnsensus-based Standards for the selection of health Measurement Instruments (COSMIN) were used to guide the evaluation of psychometric properties (Mokkink et al., 2010). In this study, 1,813 primary school children (six to 15 years old) regularly enrolled in the 12 schools were examined between July and November 2018, according to the school calendar. The municipality has an area of 69.7 km<sup>2</sup> and a population of about 17,000 (population density about 243.90 inhabitants/km<sup>2</sup>). The human development index is 0.61, with the income and education dimensions considered low (0.57 and 0.51 respectively).

A subsample of 562 children (247 girls; 48.75%) aged 8.00 to 12.99 years (10.20±1.20 years) completed the study measures. Formal permission was obtained from school authorities and informed consent was signed by parents or legal guardians. The study was conducted in accordance with the Declaration of Helsinki and approved by the Ethics Committee of the University of Pernambuco (CAAE: 83143718.3.0000.5192; CEP/UIPE: 2.520.417), as well as the approval of all participating schools.

### Procedures

#### *Knowledge and Understanding of Physical Literacy Questionnaire*

The cognitive domain of Physical Literacy was assessed with the revised version of the PLK questionnaire (Longmuir et al., 2018). The questionnaire comprises 11 items that pertain to knowledge and understanding of: daily physical activity and sedentary behavior recommendations, what is aerobic endurance and muscular endurance, healthy mean, and how to improve physical competence and get in better shape. The questionnaire includes a mix of multiple-choice questions and one question that requires participants to complete a sentence by filling in the missing words to form a brief paragraph.

#### *Cross-cultural adaptation*

The Brazilian version of the PLK was translated and cross-culturally adapted according to the recommended steps (Beaton et al., 2000): (1) translation, (2) synthesis, (3) back-translation, (4) expert committee review, and (5) pretest.

First, two sworn translators, Portuguese native speakers' specialists in English, translated the questionnaire PLK into Portuguese, blinded to the translations (steps 1 and 2). The back-translation was done by two independent translators (different from those recruited for steps one and two); they were native Portuguese speakers with a specialization in English and neither of them had access to the original English version of the manual. The English-translated versions were compared with the original version of the instrument and independently reviewed by two principal investigators (Step 3). For Step four, a panel of experts was asked

to answer a five-point Likert scale to assess the clarity of language, pertinency and practical relevance of the translated questionnaire. The expert panel consisted of four experts and two professionals: three PhD professors and one PhD student, all with five to 20 years of relevant experience in the field of physical education and motor development, and two professors of physical education with at least three years of experience. On this scale, we asked the judges to rate each translation item based on clarity (understandability), pertinency (importance to the instrument) and relevance (relevance for inclusion in the test), and to rank the item according to its hypothetical dimension. In addition, the questionnaire PLK was revised and corrected by the expert group in terms of terminology and linguistic adaptation to the Brazilian context.

A pilot test with 28 children (Step five), proportionally selected from third to sixth grade and from both sexes, was conducted with the aim of evaluating the instrument's questions in terms of quality and coherence of language and content (Marôco, 2010).

The application of the questionnaire was carried out in the classroom in the presence of the teacher and at least two members of the research team per class (between 10 and 20 children per class). After completion, each questionnaire was checked for missing answers and completion errors and, if necessary, missing information was collected individually after collective application. The application of the questionnaire took about 15 minutes. For comprehension difficulties, the item of completing the text with missing words was removed from the final version (Supplementary material 1).

Formal authorization for the translation and validation of this instrument in Brazil was obtained from Professor Mark Tremblay, the author of the original instrument in Canada. All professionals (sworn translators, specialists and professors) volunteered to develop the process of translation, adaptation and validation of the content of the PLK.

### Statistical analysis

Descriptive statistics (mean and standard deviation) were analyzed in SPSS 23. Content validity was determined by calculating the content validity coefficient (CVC) (Hernandez-Nieto et al., 2002), which assesses the relevance, clarity and pertinence of each question individually and in groups (CVCt and CVCi values  $>0.80$  are considered acceptable).

The dimensional structure of the PLK (Longmuir et al., 2018) and alternative models were considered for proposing first and second order models. To test the construct validity of the PLK, three factor models were tested: a) a unidimensional model and 11 items; b) model with three dimensions and 11 items c) model with three dimensions and 9 items d) one-dimensional model and 9 items e) model with three dimensions and 9 items - second order. The Weighted least square mean and adjusted variance were used in all analyzes (Suh, 2015). The quality of fit of the models was assessed using the Comparative Fit Index - CFI

(Bentler, 1990), the Tucker-Lewis Index - TLI (the root mean square error of approximation - RMSEA) (Steiger, 1990) and the residual standardized root mean square - SRMR (Jöreskog & Sörbom, 1981). The Bayesian Information Criterion - BIC (Schwarz, 1978) was also used to evaluate alternative models to the original three-factor model. Lower BIC values indicate better fitted models (Byrne, 2008). CFI and TLI values were considered acceptable when CFI and TLI  $>0.90$  and optimal when CFI and TLI  $>0.95$  (Hu & Bentler, 1999). On the other hand, RMSEA and SRMR values were considered appropriate when they varied between values were considered adequate when they varied between 0.05 and 0.08 (Hu & Bentler, 1999). Internal consistency was assessed using composite reliability (Colwell, 2016; Valentini & Damásio, 2016). Composite reliability (CR) is an indicator of the structural quality of a psychometric instrument (Fornell & Larcker, 1981; Hair et al., 2009), with values  $>0.60$  considered good (Bagozzi & Yi, 1988). These analyzes were conducted using the statistical packages Rstudio and Jasp 0.14.1.

Measurement invariance between sexes was investigated using a confirmatory multi-group factorial analysis using the robust maximum likelihood estimation method. This procedure consisted of comparing increasingly restrictive models that test the PLK measurement invariance assumption between groups: configural invariance (equality for shape), metric invariance (equality for factor loading), scalar invariance (equality for thresholds) and strict invariance (equality for residual variances or uniqueness). The fit of the configurational model data was assessed using the CFI and RMSEA indices. The configural model was rejected if it had CFI  $<0.90$  or RMSEA  $\geq 0.10$ . Only when the configural model showed an acceptable data fit were the weak, strong and strict invariance were performed. The metric, scalar and strict invariance models were rejected if they showed  $\Delta CFI > 0.05$  and the p-value of the Satorra-Bentler chi-square difference test of Satorra-Bentler  $<0.01$ , compared to the configural model (Satorra & Bentler, 2001).

Table 1.  
Coefficient of validity of individual and total content.

Item	Clarity	Pertinency	Relevance
1. Knowledge about physical activity guidelines	0.88	0.92	1.00
2. Knowledge about sedentary behavior guidelines	0.90	0.88	1.00
3. Cardiorespiratory fitness definition	0.90	0.92	1.00
4. Muscular fitness definition	0.90	0.92	1.00
5. Healthy means being skinny	1.00	0.92	0.92
6. Healthy means eating well	1.00	0.98	1.00
7. Healthy means not being sick	1.00	0.96	0.96
8. Healthy means feeling good	1.00	0.96	1.00
9. Healthy means looking good	0.96	0.92	1.00
10. How to improve a sport skill	1.00	0.96	1.00
11. How to get in better shape	0.90	0.92	1.00
CVC total (mean)	0.93	0.93	0.99

Note: CVC, content validity coefficient.

## Results

### Content validity

The total CVC values obtained for clarity, pertinency and relevance were 0.91, 0.94 and 0.99 respectively. The

individual item CVC values ranged from 0.84 to 1.00 and were considered acceptable.

### Construct validity and composite reliability

Table 2 shows the fit indices of all tested models from the confirmatory factor analysis. The three-factor model and 9 items showed more acceptable fit index values, followed by the three-dimensional model and 9 items-second order, which showed good fit indicators (Figure 1). Table 3 shows the standardized factor loadings of all items in the two models tested (CR>0.60).

Table 2. Suitability indices for one-dimensional, three-dimensional and second-order three-dimensional models.

Model	$\chi^2$ (df)	CFI	TLI	RMSEA	90%CI RMSEA	SRMR	BIC
<b>First Order</b>							
One dimension: 11 items	110.34 (44)	0.62	0.54	0.04	0.04-0.06	0.05	22
Three Dimensions: 11 Items	91.05 (41)	0.72	0.66	0.05	0.03-0.06	0.08	25
Three dimensions: 9 items	34.01 (24)	0.92	0.87	0.03	0.00-0.05	0.04	21
One dimension: 9 items	53.08 (27)	0.78	0.71	0.04	0.03-0.06	0.05	18
<b>Second Order</b>							
Three dimensions: 9 items	34.01 (24)	0.92	0.87	0.03	0.00-0.05	0.04	21

Note. CFI = Comparative Fit Index; TLI = Tucker-Lewis Index; RMSEA= Root Mean Square Error of Approximation; SRMR = Standardized Root Mean Square Residual; BIC = Bayesian information criterion.

Table 3. Standardized factor loadings and composite reliability.

Factor	Items	Individual loadings	Second order
1	Knowledge about physical activity guidelines	0.25	0.96
	Cardiorespiratory fitness definition	0.33	
	Muscular fitness definition	0.42	
2	Healthy means eating well	0.19	0.36
	Healthy means not being sick	0.35	
	Healthy means feeling good	0.67	
	Healthy means looking good	0.43	
3	How to improve a sport skill	0.32	0.67
	How to get in better shape	0.48	
Composite reliability		0.61	0.73

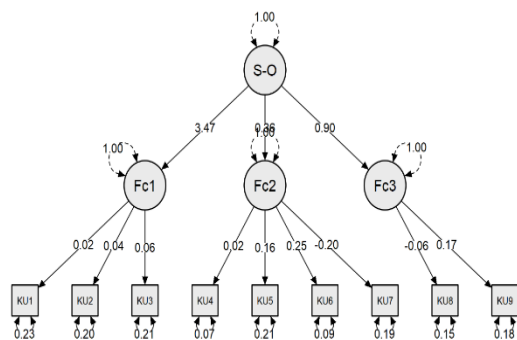

Figure 1. Model with factor loadings for the second order model with 3 factors and 9 items for the PLK. Note. KU1: Physical activity guidelines; KU2: Cardiorespiratory fitness definition; KU3: Muscular fitness definition; KU4: Healthy means eating well; KU5: Healthy means not being sick; KU6: Healthy means feeling good; KU7: Healthy means looking good; KU8: How to improve a sport skill; KU9: How to get in better shape.

### Invariance between groups

The composite reliability values of the tested models were all adequate. Table 4 shows the results of the analyzes for the between-sex invariance test for the two-factor model. As shown, the fit values for RMSEA and CFI gave a good fit for the configural model (M1), indicating that the configuration of the parameters in the bifactorial solution was similar between sexes (M2). The results presented in Table 3 show that there is metric invariance. The model still showed a satisfactory fit; in terms of the  $\Delta$ CFI and the Satorra-Bentler chi-square test. Finally, the addition of equality conditions for the residual variances in the strict invariance model (M4) did not affect the fit of the model compared to the metric model. These results support measurement invariance for the two-factor model and indicate that group comparisons can be made meaningfully for the PLK.

Table 4. Fit indices of the configural, metric, scalar and strict invariance models by sex.

MODEL	$\chi^2$ (df)	CFI	TLI	RMSEA	90%CI RMSEA	$\Delta$ CFI	$\Delta$ RMSEA
Configural	60.28 (54)	0.95	0.93	0.02	0.00-0.04	-	-
Metric	60.28 (54)*	0.95	0.93	0.02	0.00-0.04	0.00	0.00
Scalar	68.09 (60)**	0.93	0.92	0.02	0.00-0.04	0.01	0.00
Strict	83.20(69)***	0.89	0.88	0.03	0.00-0.05	0.04	0.04

Note. CFI = Comparative Fit Index; TLI = Tucker-Lewis Index; RMSEA= Root Mean Square Error of Approximation \*Configural compared to Metric, \*\*Metric compared to Scalar \*\*\*Scalar compared to Strict

### Discussion

Our study aimed to translate the PLK into Brazilian Portuguese and adapt it cross-culturally. For this, we analyzed various psychometric properties (content validity, construct validity, composite reliability, and configural, metric and scalar invariance analyses) in low-income Brazilian children. The main results of the study show that a model with 9 items and 3 factors has better fit indices, with adequate indicators of content validity, construct validity and composite reliability, as well as the lack of different sources of invariance.

The CAPL-2 has already been adapted for some languages such as Spanish (Pastor-Cisneros et al., 2022), Greek (Dania et al., 2020), Mandarin (Li et al., 2020) and Danish (Elsborg et al., 2021), although no previous study has evaluated psychometric properties related to the individual construct of the cognitive domains with the modified questionnaire (Longmuir et al., 2018), which limits the possibility of comparing our findings with those of other cross-cultural adaptations. We emphasize that the adaptation for Portuguese language from Brazil being the first to be carried out in the South American context and for low-income children. The context of vulnerability of the population studied meant that some changes had to be made to ensure understanding of the items and the quality of the responses to the various questions.

The item on physical activity comprehension, which requires children to complete a story with missing words, has

shown low loadings in other studies (Li et al., 2020; Longmuir et al., 2018) and was excluded from our version. Difficulties in understanding and writing participants and the time required to answer the question (in some cases more than 10 minutes) led us to remove the item. Further validation studies should pay particular attention to these difficulties and assess the relevance of retaining this item for the assessment of the KU domain or introducing a different format for scoring the item, such as a Likert scale or the assignment of numbers or lines.

Although all items achieved high values for clarity, pertinence and relevance in the content assessment, two items were removed due to low loadings and because they impaired the fit of the factor structure of the questionnaire, in particular the items 'knowledge of guidelines for sedentary behavior' and 'healthy means being skinny'. In the study by Longmuir et al. (2018), the authors found that the questions related to knowledge of daily physical activity and screen time guidelines, the meaning of cardiorespiratory fitness and muscular strength/endurance, and how to improve fitness or sport skills, as well as the meaning of "healthy" were identified as crucial by the Delphi panel.

The item dealing with knowledge of sedentary behavior recommendations was already identified by experts as insufficient. They suggested that sedentary time should be assessed as a behavior rather than a knowledge question (Longmuir et al., 2018). Our results showed low factor loadings for this item and that after its exclusion, there was obtained in both the single-factor models and the three-factor format. Therefore, the item was removed from the final version. Validation studies in other populations have shown problems in the assessment of the item 'how to improve in sports skills' (Dania et al., 2020; Li et al., 2020), which was not observed in our evaluation and in the scores obtained in the construct evaluation.

Two items on the question of what it means to be healthy had low factor loadings: 'being skinny' and 'eating well' (both 0.30). However, removing the item 'healthy means eating well' affected the questionnaire's quality of fit, so we retained this item. Another reason for retaining this item is its relevance as important content for health education at schools, which is supported by the adoption of a healthy diet and an active lifestyle (Ramires et al., 2023; Xu et al., 2022). In addition, the selection of items resulted in adequate composite reliability, which had not yet been assessed in other CAPL-2 validation studies.

Differences between boys and girls in their preference for physical activity and sport are widely recognized (Kretschmer et al., 2023; Nascimento et al., 2023), which could have a direct impact on how they recognize the recommendations (both physical activity and sedentary behavior), the meaning of what it means to be healthy, cardiorespiratory/strength fitness and what to do to improve fitness/skills. Our results are not only the first to investigate the invariance of the PLK, but also show that the instrument can be considered suitable for simultaneously assessing the cognitive domain and comparing it across sexes. Mota et al.

(2022), which developed an instrument to monitor PL in Portuguese adolescents, also confirmed invariance in the assessment of PL.

Despite our relevant findings, some limitations should be considered. First, the evaluation in a sample of low-income Brazilian children limits the generalization to the assessment of PL in the entire population of Brazilian children. However, this is the first study to investigate the psychometric properties of the CAPL-2 questionnaire for cognitive domains in a sample of children aged 8 to 12 years in Brazil and South America, and it is also the first study with low-income children. Future studies should investigate the use of the Brazilian version of the PLK in different regions of Brazil and at different socioeconomic levels. We also consider the lack of assessment of the instrument's reproducibility to be an important limitation, as the same participants were not assessed at different time points (e.g. 7 or 14 days later). However, due to logistical and financial difficulties, this was not possible in the current study. We therefore suggest that future studies evaluate the reliability of the PL.

Our study not only pioneers the assessment of PL in Brazilian children but is also the first to examine the composite reliability and sex invariance of the CAPL-2 questionnaires. Because this is the first validated instrument to assess the cognitive domain of PL in Brazil and South America, as well as the first instrument validated exclusively for low-income children in the world, we recommend that researchers use this instrument in different regions of Brazil and in different socioeconomic status levels. By using the PLK and other PL assessment measures, physical education teachers and policy makers can obtain valuable information about the physical development and motor skills of children and adolescents. This data can help in the development of more effective programs and interventions that promote.

## Conclusion

Based on the results obtained, we conclude that PLK is a useful instrument for the assessment of cognitive domain of PL in the low-income Brazilian children and has an adequate structure to assess boys and girls similarly.

## Author Contributions

Gonçalves JG, Luz LGO and Henrique RSH designed and directed the study. Prazeres TMP and Henrique RSH did the data collection, prepare the data set, cleaned it. Henrique RSH and Bandeira PFR did the analyses. Gonçalves JG, Luz LGO, Bandeira PFR and Henrique RSH drafted the manuscript. Lima VF, Maia DEF, Santos TM, Gaya AR and Santos MAM reviewed and edited the study. All authors provided critical comments, helped and approved the final version.

## Acknowledgments

This work was supported by the Foundation for Science and Technology Development of the State of Pernambuco

(FACEPE), under grant APQ-1762-4.09/22. The authors thank all children and parents for their participation in the study, and to the schools who participated in this study. Also, we thank all the team members of the Healthy Life Project in Lagoa do Carro: a family-based study who contributed to the data collection.

### Data Availability Statement

The data that support the findings of this study are available from the corresponding author, Rafael dos Santos Henrique, upon reasonable request.

### Declaration of Interest Statement

The authors inform that there is no conflict of interest in this study.

### References

- Bagozzi, R. P., & Yi, Y. (1988). On the evaluation of structural equation models. *Journal of the Academy of Marketing Science*, 16(1), 74-94. <https://doi.org/10.1007/BF02723327>
- Barnett, L. M., Mazzoli, E., Hawkins, M., Lander, N., Lubans, D. R., Caldwell, S., ... & Salmon, J. (2022). Development of a self-report scale to assess children's perceived physical literacy. *Physical Education and Sport Pedagogy*, 27(1), 91-116. <https://doi.org/10.1080/17408989.2020.1849596>
- Beaton, D. E., Bombardier, C., Guillemin, F., & Ferraz, M. B. (2000). Guidelines for the process of cross-cultural adaptation of self-report measures. *Spine*, 25(24), 3186-3191. <https://doi.org/10.1097/00007632-200012150-00014>
- Bentler, P. M. (1990). Fit indexes, Lagrange multipliers, constraint changes and incomplete data in structural models. *Multivariate Behavioral Research*, 25(2), 163-172. [https://doi.org/10.1207/s15327906mbr2502\\_3](https://doi.org/10.1207/s15327906mbr2502_3)
- Byrne, B. M. (2008). Testing for multigroup equivalence of a measuring instrument: A walk through the process. *Psicothema*, 20(4), 872-882. <https://www.psicothema.com/pdf/3569.pdf>
- Carl, J., Bryant, A. S., Edwards, L. C., Bartle, G., Birch, J. E., Christodoulides, E., ... & Elsborg, P. (2023). Physical literacy in Europe: The current state of implementation in research, practice, and policy. *Journal of Exercise Science & Fitness*, 21(1), 165-176. <https://doi.org/10.1016/j.jesf.2022.12.003>
- Carolo, D., Onofre, M., & Martins, J. (2023). Orígenes y definición del constructo de alfabetización física: de la comprensión conceptual a la creación colectiva de un referencial europeo (Origins and definition of the physical literacy construct: from conceptual understanding to the collective creation of a European referential). *Retos*, 48, 761-774. <https://doi.org/10.47197/retos.v48.97380>
- Colwell, S. R. (2016). *The Composite Reliability Calculator User's Guide*. Technical Report. <https://doi.org/10.13140/RG.2.1.4298.0888>
- Contreras-Zapata, K., Roa-Quintero, T., Vásquez-Muñoz, C., Castillo-Retamal, F., & Castillo-Retamal, M. (2023). Aproximación a la implementación de la alfabetización física en Chile: una revisión narrativa (Approach to physical literacy implementation in Chile: a narrative review). *Retos*, 47, 96-102. <https://doi.org/10.47197/retos.v47.94922>
- Corbin, C. B. (2016). Implications of physical literacy for research and practice: A commentary. *Research Quarterly for Exercise and Sport*, 87(1), 14-27. <https://doi.org/10.1080/02701367.2016.1124722>
- Dania, A., Kaioglou, V., & Venetsanou, F. (2020). Validation of the Canadian Assessment of Physical Literacy for Greek children: Understanding assessment in response to culture and pedagogy. *European Physical Education Review*, 26(4), 903-919. <https://doi.org/10.1177/1356336X20904079>
- Edwards, L. C., Bryant, A. S., Keegan, R. J., Morgan, K., & Jones, A. M. (2017). Definitions, foundations and associations of physical literacy: A systematic review. *Sports Medicine*, 47(1), 113-126. <https://doi.org/10.1007/s40279-017-0815-7>
- Elsborg, P., Melby, P. S., Kurtzhals, M., Tremblay, M. S., Nielsen, G., & Bentsen, P. (2021). Translation and validation of the Canadian assessment of physical literacy-2 in a Danish sample. *BMC Public Health*, 21(1), 2236. <http://doi.org/10.1186/s12889-021-12301-7>
- Fornell, C., & Larcker, D. F. (1981). Structural equation models with unobservable variables and measurement error: Algebra and statistics. *Journal of Marketing Research*, 18(3), 382-388. <http://doi.org/10.2307/3150980>
- Gunnell, K. E., Longmuir, P. E., Barnes, J. D., Belanger, K., & Tremblay, M. S. (2018). Refining the Canadian Assessment of Physical Literacy based on theory and factor analyses. *BMC Public Health*, 18, 1-15. <http://doi.org/10.1186/s12889-018-5899-2>
- Hair, J. F., Black, W. C., Babin, B. J., Anderson, R. E., & Tatham, R. L. (2009). *Análise multivariada de dados*. Porto Alegre: Bookman Editora.
- Hernández-Nieto, R. A. (2002). *Contributions to statistical analysis* (p. 193). Mérida: Universidad de Los Andes.
- Hu, L. T., & Bentler, P. M. (1999). Cutoff criteria for fit indexes in covariance structure analysis: Conventional criteria versus new alternatives. *Structural Equation Modeling: a multidisciplinary journal*, 6(1), 1-55. <http://doi.org/10.1080/10705519909540118>
- Hurter, L., Essiet, I., Duncan, M., Roberts, W. M., Lewis, K., Goss, H., Morris, J. L., & Fowweather, L. (2022). *Physical literacy consensus for England: Evidence review*. Liverpool: Liverpool John Moores University.

- International Physical Literacy Association. (2017). *Defining physical literacy*. <https://www.physical-literacy.org.uk/blog/defining-physical-literacy/>
- Jöreskog, K. G., & Sörbom, D. (1982). Recent developments in structural equation modeling. *Journal of Marketing Research*, 19(4), 404-416. <http://doi.org/10.2307/3151714>
- Keegan, R. J., Barnett, L. M., Dudley, D. A., Telford, R. D., Lubans, D. R., Bryant, A. S., ... & Evans, J. R. (2019). Defining physical literacy for application in Australia: a modified Delphi method. *Journal of Teaching in Physical Education*, 38(2), 105-118. <http://doi.org/10.1123/jtpe.2018-0264>
- Keegan, R., Barnett, L., & Dudley, D. (2017). *Physical literacy: informing a definition and standard for Australia*. Australian Sports Commission.
- Kretschmer, L., Salali, G. D., Andersen, L. B., Hallal, P. C., Northstone, K., Sardinha, L. B., ... & International Children's Accelerometry Database (ICAD) Collaborators Andersen LB Anderssen S. Cardon G. Davey R. Jago R. Janz KF Kriemler S. Møller N. Northstone K. Pate R. Puder JJ Reilly J. Salmon J. Sardinha LB van Sluijs EMF. (2023). Gender differences in the distribution of children's physical activity: evidence from nine countries. *International Journal of Behavioral Nutrition and Physical Activity*, 20(1), 103. <http://doi.org/10.1186/s12966-019-0870-4>
- Li, M. H., Whitehead, M., Green, N., Ren, H., Cheng, C. F., Lin, L. L. C., ... & Sum, R. K. W. (2022). Operationally defining physical literacy in Chinese culture: results of a meta-narrative synthesis and the Panel's recommendations. *Journal of Exercise Science & Fitness*, 20(3), 236-248. <http://doi.org/10.1016/j.jesf.2022.05.002>
- Li, M. H., Sum, R. K. W., Tremblay, M., Sit, C. H. P., Ha, A. S. C., & Wong, S. H. S. (2020). Cross-validation of the Canadian Assessment of Physical Literacy second edition (CAPL-2): The case of a Chinese population. *Journal of Sports Sciences*, 38(24), 2850-2857. <http://doi.org/10.1080/02640414.2020.1803016>
- Longmuir, P. E., Gunnell, K. E., Barnes, J. D., Belanger, K., Leduc, G., Woodruff, S. J., & Tremblay, M. S. (2018). Canadian Assessment of Physical Literacy Second Edition: a streamlined assessment of the capacity for physical activity among children 8 to 12 years of age. *BMC Public Health*, 18(2), 1-12. <http://doi.org/10.1186/s12889-018-5902-y>
- Longmuir, P. E., Boyer, C., Lloyd, M., Yang, Y., Boiarskaia, E., Zhu, W., & Tremblay, M. S. (2015). The Canadian assessment of physical literacy: methods for children in grades 4 to 6 (8 to 12 years). *BMC Public Health*, 15, 1-11. <http://doi.org/10.1186/s12889-015-2106-6>
- Marôco, J. (2014). *Análise de equações estruturais: Fundamentos teóricos, software & aplicações*. ReportNumber, Lda.
- Martins, J., Onofre, M., Mota, J., Murphy, C., Repond, R. M., Vost, H., ... & Dudley, D. (2021). International approaches to the definition, philosophical tenets, and core elements of physical literacy: A scoping review. *Prospects*, 50(1-2), 13-30. <http://doi.org/10.1007/s1125-020-09466-1>
- Mokkink, L. B., Terwee, C. B., Knol, D. L., Stratford, P. W., Alonso, J., Patrick, D. L., ... & De Vet, H. C. (2010). The COSMIN checklist for evaluating the methodological quality of studies on measurement properties: a clarification of its content. *BMC Medical Research Methodology*, 10, 1-8. <http://doi.org/10.1186/1471-2288-10-22>
- Mota, J., Martins, J., & Onofre, M. (2021). Portuguese Physical Literacy Assessment Questionnaire (PPLA-Q) for adolescents (15–18 years) from grades 10–12: Development, content validation and pilot testing. *BMC Public Health*, 21, 1-22. <http://doi.org/10.1186/s12889-021-12230-5>
- Nascimento, J. Y. V., Lima, C. V. P., Giudicelli, B. B., Lima, L. M. P., Bandeira, P. F. R., dos Santos Pinheiro, I. K. A., ... & de Oliveira Luz, L. G. (2023). Fatores associados aos comportamentos ativo e sedentário em adolescentes brasileiros: uma análise de redes. *Revista Brasileira de Atividade Física & Saúde*, 28(1), 1-10. <http://doi.org/10.12820/rbafs.28e0243>
- Pastor-Cisneros, R., Carlos-Vivas, J., Adsuar, J. C., Barrios-Fernández, S., Rojo-Ramos, J., Vega-Muñoz, A., ... & Mendoza-Muñoz, M. (2022). Spanish translation and cultural adaptation of the Canadian assessment of physical Literacy-2 (CAPL-2) questionnaires. *International Journal of Environmental Research and Public Health*, 19(14), 8850. <http://doi.org/10.3390/ijerph19148850>
- Ramires, V. V., Dos Santos, P. C., Barbosa Filho, V. C., da Silva Bandeira, A., Tenório, M. C. M., de Camargo, E. M., ... & Silva, K. S. (2023). Physical Education for Health Among School-Aged Children and Adolescents: A Scoping Review of Reviews. *Journal of Physical Activity and Health*, 20(7), 586-599. <http://doi.org/10.1123/jpah.2022-0395>
- Santos, C., Bustamante, A., Vasconcelos, O., Pereira, S., Garganta, R., Lightfoot, J. T., ... & Maia, J. (2022). Sibling Resemblances in Physical Fitness in Three Distinct Regions in Peru: The Peruvian Sibling Study on Growth and Health. *Behavior Genetics*, 52(3), 195-204. <http://doi.org/10.1007/s10519-022-10099-7>
- Satorra, A., & Bentler, P. M. (2001). A scaled difference chi-square test statistic for moment structure analysis. *Psychometrika*, 66(4), 507-514. <http://doi.org/10.1007/BF02296192>
- Schwarz, G. (1978). Estimating the dimension of a model. *The Annals of Statistics*, 6(2), 461-464. <http://doi.org/10.1214/aos/1176344136>
- Shearer, C., Goss, H. R., Boddy, L. M., Knowles, Z. R., Durden-Myers, E. J., & Fowweather, L. (2021). Assessments related to the physical, affective and cognitive domains of physical literacy amongst children aged 7–11.9 years: a systematic review. *Sports Medicine-Open*, 7(1), 1-40. <http://doi.org/10.1186/s40798-021-00324-8>

- Steiger, J. H. (1990). Structural model evaluation and modification: An interval estimation approach. *Multivariate Behavioral Research*, 25(2), 173-180. [http://doi.org/10.1207/s15327906mbr2502\\_4](http://doi.org/10.1207/s15327906mbr2502_4)
- Suh, Y. (2015). The performance of maximum likelihood and weighted least square mean and variance adjusted estimators in testing differential item functioning with nonnormal trait distributions. *Structural Equation Modeling: A Multidisciplinary Journal*, 22(4), 568-580. <http://doi.org/10.1080/10705511.2014.937669>
- Tremblay, M. S., Costas-Bradstreet, C., Barnes, J. D., Bartlett, B., Dampier, D., Lalonde, C., ... & Yessis, J. (2018). Canada's physical literacy consensus statement: process and outcome. *BMC Public Health*, 18(2), 1-18. <http://doi.org/10.1186/s12889-018-5903-x>
- Tucker, L. R., & Lewis, C. (1973). A reliability coefficient for maximum likelihood factor analysis. *Psychometrika*, 38(1), 1-10. <http://doi.org/10.1007/BF02291170>
- Valentini, F., & Damásio, B. F. (2016). Variância média extraída e confiabilidade composta: indicadores de precisão. *Psicologia: teoria e pesquisa*, 32(2), e322225. <http://doi.org/10.1590/0102-3772e322225>
- Von Elm, E., Altman, D. G., Egger, M., Pocock, S. J., Gøtzsche, P. C., & Vandenbroucke, J. P. (2007). The Strengthening the Reporting of Observational Studies in Epidemiology (STROBE) statement: guidelines for reporting observational studies. *The Lancet*, 370(9596), 1453-1457. <http://doi.org/10.1371/journal.pmed.0040296>
- Xu, Y., Bi, X., Gao, T., Yang, T., Xu, P., Gan, Q., ... & Zhang, Q. (2022). Effect of School-Based Nutrition and Health Education for Rural Chinese Children. *Nutrients*, 14(19), 3997. <http://doi.org/10.3390/nu14193997>

#### Datos de los/as autores/as y traductor/a:

Jéssica Gomes Gonçalves	<a href="mailto:jessica.gomesgoncalves@ufpe.br">jessica.gomesgoncalves@ufpe.br</a>	Autor/a
Leonardo Gomes de Oliveira Luz	<a href="mailto:leonardoluz.ufal@gmail.com">leonardoluz.ufal@gmail.com</a>	Autor/a
Paulo Felipe Ribeiro Bandeira	<a href="mailto:paulo.bandeira@urca.br">paulo.bandeira@urca.br</a>	Autor/a
Thaliane Mayara Pessôa dos Prazeres	<a href="mailto:thalianemayara@hotmail.com">thalianemayara@hotmail.com</a>	Autor/a
Victor Ferreira Lima	<a href="mailto:victor.ferreiralima@ufpe.br">victor.ferreiralima@ufpe.br</a>	Autor/a
Douglas Eduardo Ferreira Maia	<a href="mailto:douglas.maia@ufpe.br">douglas.maia@ufpe.br</a>	Autor/a
Tony Meireles dos Santos	<a href="mailto:tony.meireles@ufpe.br">tony.meireles@ufpe.br</a>	Autor/a
Anelise Reis Gaya	<a href="mailto:anegaya@gmail.com">anegaya@gmail.com</a>	Autor/a
Marcos André Moura dos Santos	<a href="mailto:mmoura23@gmail.com">mmoura23@gmail.com</a>	Autor/a
Rafael dos Santos Henrique	<a href="mailto:rafael.shenrique@ufpe.br">rafael.shenrique@ufpe.br</a>	Autor/a – Traductor/a
Ana Paula dos Santos Henrique	<a href="mailto:ana_paula_henrique@hotmail.com">ana_paula_henrique@hotmail.com</a>	Traductor/a